

Operation guide

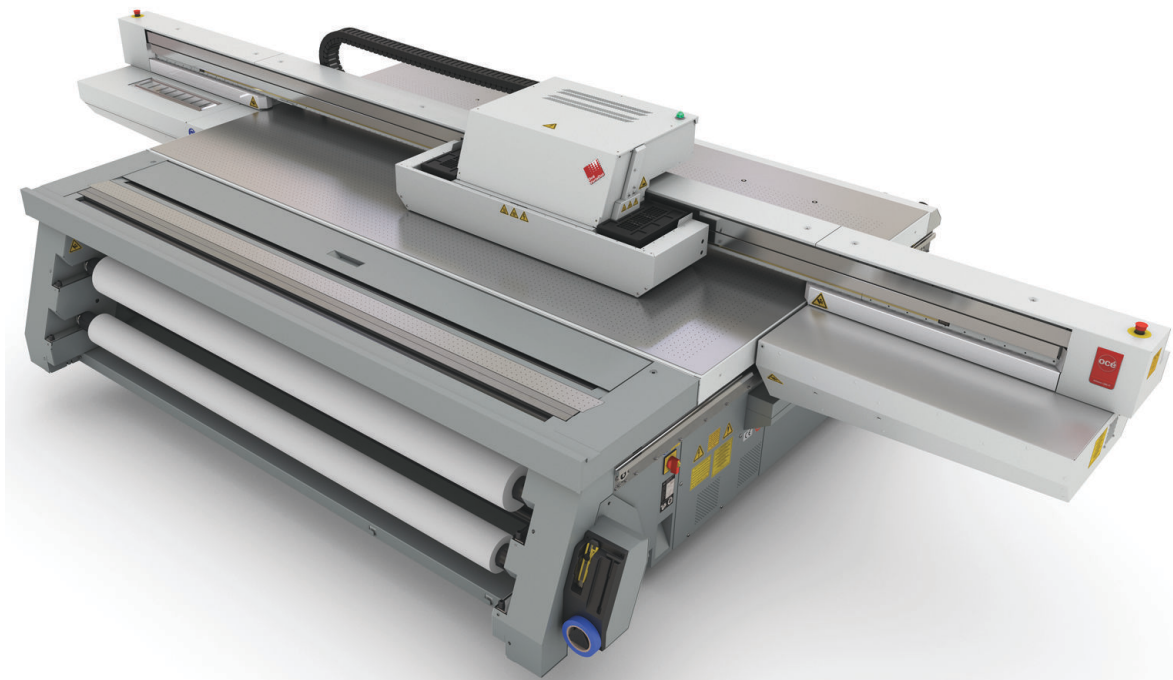

Océ Arizona 1200 Series

User Manual



A CANON COMPANY

Copyright library

Copyright

Copyright 2016, 2019 Océ.

Illustrations and specifications do not necessarily apply to products and services offered in each local market. No part of this publication may be reproduced, copied, adapted or transmitted, transcribed, stored in a retrieval system, or translated into any language or computer language in any form or by any means, electronic, mechanical, optical, chemical, manual, or otherwise, without the prior written permission of Océ.

OCÉ MAKES NO WARRANTY OF ANY KIND WITH REGARD TO THE CONTENTS OF THIS PUBLICATION, EITHER EXPRESS OR IMPLIED, EXCEPT AS PROVIDED HEREIN, INCLUDING WITHOUT LIMITATION, THEREOF, WARRANTIES AS TO MARKETABILITY, MERCHANTABILITY, FITNESS FOR A PARTICULAR PURPOSE OF USE OR NON-INFRINGEMENT. OCÉ SHALL NOT BE LIABLE FOR ANY DIRECT, INCIDENTAL, OR CONSEQUENTIAL DAMAGES OF ANY NATURE, OR LOSSES OR EXPENSES RESULTING FROM THE USE OF THE CONTENTS OF THIS PUBLICATION.

Océ reserves the right to revise this publication and to make changes from time to time in the content hereof without obligation to notify any person of such revision or changes.

Contents

Chapter 1	
Introduction.....	7
Preface	8
Printer Specifications.....	10
Chapter 2	
Product Compliance.....	11
Product Compliance.....	12
Chapter 3	
Safety Information.....	15
Safety and Environment Information.....	16
Flush.....	26
UV Curing System	27
Safety Interlock System.....	28
Safety Awareness.....	29
Roll Media Safety Awareness.....	37
Chapter 4	
How to Navigate the User Interface.....	39
Operator Interface Hardware.....	40
Printer Interface Software.....	42
Print Job Control Module.....	44
Maintenance Tasks.....	52
Counters Module.....	53
Settings Module.....	54
Tools and Utilities Module.....	57
Software Update Module.....	59
Chapter 5	
How to Operate Your Océ Arizona Printer.....	61
Training Requirements.....	62
How to Power ON and Off.....	63
How to Set Up a Print Job.....	64
Managing the Table Vacuum.....	66
The Table Vacuum System.....	66
Using Vacuum Zones - Metric Zones.....	68
Print the Metric Zone Map.....	68
Imperial Vacuum Zones.....	70
Print Imperial Zone Map.....	71
Batch Mode Printing.....	72
Step and Repeat Printing.....	75
Managing Media.....	77
How to Handle Media.....	77
Media Registration.....	79

Chapter 6

Operating the Océ Arizona 1200 XT.....	83
Océ Arizona 1200 XT Features.....	84
How to Use the Océ Arizona 1200 XT Vacuum System.....	85
How to Print With Dual Origins.....	87

Chapter 7

Roll Media Option.....	89
Hardware.....	90
Specifications.....	92
Foot Pedal Switch Functions.....	93
Roll Media Manager.....	94
Loading Media.....	96
Loading the Media - Standard Method.....	98
Loading the Media - Alternate Method	101
Unloading and Removing Media.....	103
Setting Up a Roll Media Job.....	104
Set a Hold on a Roll Job.....	104
Printing on Roll Media	106
Determining the Media Step Correction Factor.....	109
Media Edge Protectors.....	110

Chapter 8

Static Suppression Option.....	113
Reduce Static with the Static Suppression Option.....	114
How to Change the Height of the Bar.....	115

Chapter 9

How to Manage a White Ink Workflow.....	117
Operator Guidelines for White Ink.....	118
White Ink Workflow Overview.....	119
Varnish Workflow Overview.....	122
Configure ONYX Software for White Ink.....	124
White Ink ONYX Media Profiles.....	126
How to Prepare White Ink/Varnish Print Jobs.....	127
Select the Best Workflow.....	127
How to Setup a Printer Flood Fill.....	128
How to Create Spot Data with the Spot Layer Tool.....	129
How to Access the Spot Layer Tool.....	131
How to Create Spot Data in Photoshop.....	133
How to Prepare Spot Data in Adobe Illustrator.....	136
How to Overprint Spot Data in Illustrator.....	138
How to Place Raster Images in Illustrator	141
How to Create a Spot Channel Path in Illustrator.....	142
How to Set Up a File for Preflight's Spot Layer Tool.....	144
How to Name Your Spot Data in Illustrator.....	145
White Ink QuickStart.....	147
How to Print White Ink Jobs.....	149
Varnish QuickStart.....	153
How to Print Varnish Jobs.....	155
How to Get Good Results With Varnish.....	157

Chapter 10

Ink System Management.....	161
Arizona Printer Ink.....	162
Change Ink Bags.....	164

Chapter 11
Troubleshooting..... 165
 Troubleshooting Overview..... 166

Chapter 12
Printer Maintenance..... 167
 Maintenance Guidelines..... 168
 Maintenance Procedures..... 169
 Check Printhead Nozzle Performance..... 169
 Manual Printhead Maintenance..... 171
 Recover Nozzles by (Optional) AMS..... 175
 Cleaning the Automatic Maintenance System (AMS) 176
 Clean Horizontal Surfaces..... 178
 Clean Carriage Underside..... 179
 Maintain White Ink..... 181
 Clean the Printhead Nozzles..... 182
 Replace UV Lamp Filter..... 185
 Remove Ink from the Table..... 187
 Empty Ink Waste Trays..... 188
 Fill Coolant Bottle 192
 Clean Gantry Rails..... 193
 Change Ink Filter 195
 Bleed Ink Filter..... 198
 Change Both UV Lamp Bulbs..... 201
 Roll Media Option Maintenance..... 206
 RMO Maintenance Guidelines..... 206
 How to Clean the Rubber Capstan..... 207
 How to Remove Stains (coffee, tea, soda pop, etc.)..... 208
 How to Remove Uncured Ink on the Capstan..... 209

Chapter 13
Regulation Notices..... 213

Appendix A
Application Information..... 219
 Application Resources on the Web Site..... 220

Index..... 223

Chapter 1

Introduction

Preface

Introduction

This manual provides the operator with information about the following Océ Arizona 1200 Series UV flatbed inkjet printers:

- Océ Arizona 1240 GT
- Océ Arizona 1240 XT
- Océ Arizona 1260 GT
- Océ Arizona 1260 XT
- Océ Arizona 1260 GT L
- Océ Arizona 1260 XT L
- Océ Arizona 1280 GT
- Océ Arizona 1280 XT

Multi-Language Support

The printer's user interface software supports multiple languages. To select your preferred language and other setup information, refer to the Settings Module in Chapter 4.

This manual is available in other languages. You can download a PDF file of the manual in all of the languages that we support from our websites: <http://downloads.oce.com> or <https://dgs.oce.com>.

Océ on the Internet

For further information on documentation and support for your printer or for information on other Océ products, please visit our websites: <http://downloads.oce.com> or <https://dgs.oce.com>.

Safety Information

Safety information for handling inks, consumables, and operating the printer can be found in Chapter 3.

Customer Service

If your printer malfunctions and you are unable to resolve the problem, field service technicians can be dispatched to your site to conduct repairs. Service visits are paid for by the customer, either under a maintenance agreement, by purchase order or prepayment. Time and material rates are charged for any service not covered under a maintenance agreement.

Before calling to report a problem, gather as much information about the problem as possible and have it ready to provide to your customer care center. The more information you can provide initially, the more quickly the problem can be corrected.

Responsibilities of the Operator

The printer operator must be properly trained. Océ provides training for the operator in the use of the printer hardware and software at the time of installation. It is the customer's responsibility to ensure that only properly trained personnel operate the printer. Operators must be fully versed in the operation of ONYX Thrive® or ProductionHouse®. For any operator unfamiliar with these applications, ONYX training is required. Training courses are available; contact your local Océ representative.

The operator or other trained personnel are expected to handle all user maintenance as detailed in the User Manual, and also replacement of consumable parts (except print heads). If your site has a technician in charge of printer maintenance, that person is the optimal candidate. While any

trained operator may perform routine maintenance, the best maintenance results from familiarity with the printer's internal operation and history.

Responsibilities of the Service Technician

Field service technicians must have Océ service training. The service technician is responsible for all repairs, upgrading and modification requested by the customer or mandated by the Océ Service and Support Group. The service technician who installs the printer will also provide training for the operator that covers all of the basic skills required to operate the printer. Service personnel are furnished with proper tools for the installation and maintenance of the printer. In addition to the tools and custom kits, each engineer will have basic tools for proper maintenance and servicing.

Printer Specifications

Introduction

Your Océ Arizona 1200 Series printer is capable of producing large format images on various rigid and flexible media. The printers consist of a flatbed vacuum table and moving gantry. Media is held flat and stationary on the vacuum table during printing. The gantry contains a carriage that sweeps across the table as the gantry moves in steps along the length of the table to print an image on the media. A Roll Media Option is available to facilitate printing on roll media.



NOTE

All specifications in this document are subject to change without notice.

Specifications

Feature	Specification
Printing Technology	Piezoelectric inkjet with Océ VariaDot™ imaging technology "
Maximum Media Size	GT models: 2.5m (98.4") x 1.25m (49.2") XT models: 2.5m (98.4") x 3.08m (121.3")
Media Thickness	Maximum: 50.8 mm (2.0")
Maximum Print Size	GT models: 2.51m (98.8") x 1.26m (49.6") XT models: 2.51m (98.8") x 3.09m (121.6")
Media Weight	Maximum: 34 kg/m ² (7 lbs/ft ²)
Nozzle Drop Volume:	Variable droplet sizes: 6 to 42 picolitres
User Interface	LCD flat-panel monitor and mouse on a user positioned podium.
Curing System	UV curing lamps with variable power settings.
Power Requirements Refer to the PSDS available from the Océ Downloads website: http://global.oce.com/support/ .	Dual Inlets 200-240Vac 50/60Hz Circuit Breaker: North America 20A, European Union 16A.
Compressed Air	Pressure (max): 827 kpa (120 psi) Peak flow: 113 liters/min (4 cfm) at 690 kpa (100psi)
Environmental Conditions	Temperature: 18°C to 30°C (64°F to 86°F). Relative humidity: 30% to 70% (Non-condensing) Room Ventilation Rate (minimum): 1200m ³ /hr
BTU Output	GT models: 14,000 BTU per hour (4100 watts) under continuous operation. XT models: 17,000 BTU per hour (4980 watts) under continuous operation.
Hardware Interface	USB, Ethernet TCP/IP, 100 base-T (or Gigabyte, if supported by the local network).
Image Processing Software	ONYX® Thrive™ 12 (421 configuration or greater recommended) ONYX® ProductionHouse™ 12 (available, not recommended)

Chapter 2

Product Compliance

Product Compliance

CE Declaration of Conformity



A CANON COMPANY

CE-DoC HYB340_HYB360-c



DECLARATION OF CONFORMITY

Manufacturer Océ-Technologies B.V.
Sint Urbanusweg 43
5914 CA Venlo
The Netherlands

Commercial product name: Océ Arizona® 12x0 GT and Océ Arizona® 12x0 XT
[x – can be numeric 4, 6 or 8]

Model number: HYB340 and HYB360

Product description: Flatbed Printing Machine

We Océ-Technologies B.V. declare under our sole responsibility that the above product(s) to which this declaration relates are in conformity with essential requirements of the following EC directive(s) and Regulations by applying the following referred standard(s):

<i>EC Directive(s) and Commission Regulations</i>	<i>Reference of standard(s) and amendment(s)</i>
2006/42/EC (Machinery)	EN 1010-1:2004+A1:2010 EN 1010-2:2006+A1:2010 EN 60204-1:2006+A1:2009/AC:2010 EN ISO 12100:2010 EN ISO 13849-1:2015 EN ISO 13849-2:2012 EN ISO 13857:2008, EN 349:1993+A1:2008, EN ISO 14120:2015
2014/30/EU (EMC)	EN 12198-1:2000+A1:2008 EN 12198-2:2002+A1:2008 EN 12198-3:2002+A1:2008 EN 55011:2009+A1:2010 EN 61000-6-2:2005 EN 61000-6-4:2007+A1:2011 EN 61000-3-2:2014 EN 61000-3-3:2013
2014/53/EU (RED)	EN 300 330 V2.1.1 EN 301 489-1 V1.9.2 EN 301 489-3 V1.6.1
2011/65/EC (RoHS)	EN 50581:2012

First year of labeling: 2015

Venlo, The Netherlands
October 2018



Hans Geelen

Senior Vice President
Research & Development

The authorized person for the compilation of the relevant technical documentation is Océ-Technologies B.V.

This declaration confirms solely the compliance with the above mentioned directives and refers exclusively to the condition of the product when it has been put onto the market. It does not comprise any parts or components added by the customer or changes made to the product thereafter. It does neither warrant nor represent certain features nor does it provide any guarantee whatsoever. Please observe the safety instructions provided in the accompanying product documentation.

Marking Declaration Table China Pollution Act

Part Name	Lead (Pb)	Toxic and Hazardous Substances or Elements in the Product				
		Mercury (Hg)	Cadmium (Cd)	Hexavalent Chromium (CrVI)	Polybrominated biphenyls (PBB)	Polybrominated diphenylether (PBDE)
UV Curing Lamp	0	X	0	0	0	0
Inkjet Heads	X	0	0	0	0	0

0: indicates that the content of the toxic and hazardous substance in all the homogeneous materials of the part is below the concentration limit requirement as described in GB/T26572.

X: indicates that the content of the toxic and hazardous substance in at least one homogeneous material of the part exceeds the concentration limit requirement as described in GB/T26572.

Chapter 3

Safety Information

Safety and Environment Information

Important Safety and Environment User Information

Before using Your printing system, make sure that it is properly installed and that You have read and understand the User Documentation in order to operate the system safely and in accordance with its functional offerings. When using Your machine make sure to always comply with the User Documentation.

Warning and caution indicators

In order to warn and make aware all persons operating the machine of possible risks, dangers and/or hazards, safety warning labels have been applied where required. For safe operation it is important to understand the meaning of any label. Make sure you read and understand all label descriptions before you start operating the machine.

In order to avoid potential hazards, make sure that preventive and remedial maintenance is executed by qualified and trained service technicians.

Disclaimer:

OCE MAKES NO WARRANTY OF ANY KIND WITH REGARD TO THE CONTENT OF THIS DOCUMENTATION AND ITS COMPLETENESS, EITHER EXPRESS OR IMPLIED, EXCEPT AS PROVIDED HEREIN, INCLUDING WITHOUT LIMITATION, THEREOF, WARRANTIES AS TO MARKETABILITY, MERCHANTABILITY AND FITNESS FOR A PARTICULAR PURPOSE OF USE OR NON-INFRINGEMENT. OCÉ SHALL NOT BE LIABLE FOR ANY DIRECT, INCIDENTAL, OR CONSEQUENTIAL DAMAGES OF ANY NATURE, OR LOSSES OR EXPENSES RESULTING FROM THE USE OF THIS DOCUMENTATION.

While every precaution has been taken in the preparation of this documentation Océ assumes no responsibility for errors or omissions contained herein. Océ reserves the right to revise this documentation and to make changes from time to time.

Notes

- In some regions where this product is sold the following commercial product name(s) may be registered as model number(s).

Commercial product name	model number
Océ Arizona 1240 GT	HYB340
Océ Arizona 1260 GT	HYB340
Océ Arizona 1260 GT L	HYB340
Océ Arizona 1280 GT	HYB340
Océ Arizona 1240 XT	HYB360
Océ Arizona 1260 XT	HYB360
Océ Arizona 1260 XT L	HYB360
Océ Arizona 1280 XT	HYB360

- Depending on the context, the terms “system”, “machine”, and “equipment” used in the User Documentation mean the Océ printing system for which this User Documentation shall apply.
- Some consumables and materials designated to be used by this machine are accompanied with Safety Data Sheets. Please refer to the corresponding Safety Data Sheets for specific





Safety and Environment Information and operating instructions. You may download the actual Safety Data Sheets from the support site of your product at "<http://downloads.oce.com/>".

- The machine bears the CE-mark to show conformance with applicable legal requirements. The relevant CE Declaration of Conformity is part of the User Documentation. You may also download it from the support site of your product at "<http://downloads.oce.com/>".



Océ shall not be liable for damages from:

- Failure to comply with the User Documentation;
- Work performed incorrectly on the machine;
- Unauthorized modifications.











The following indicators are used in the User Documentation to identify and categorize the level of the seriousness of hazard:



Symbol	Type	Description
	WARNING	Indicates a warning concerning operations that may lead to injury or even death to persons if not performed correctly. To use the machine safely, always pay attention to these warnings.
	CAUTION	Indicates a caution concerning operations that may lead to injury to persons if not performed correctly. To use the machine safely, always pay attention to these cautions.
	IMPORTANT	Indicates operational requirements and restrictions. Be sure to read these items carefully to operate the machine correctly, and avoid damage to the machine or property.
	PROHIBITED	Indicates an operation that must not be performed. Read these items carefully, and make sure not to perform the described operations.
	NOTE	Indicates a clarification of an operation, or contains additional explanations for a procedure. Reading these notes is highly recommended.

Personal protection symbols

Symbol	Type	Description
	Eye protection	Use the mentioned type of eye protection when you perform this task or action.
	Hand protection	Wear the mentioned type of gloves when you perform this task or action.
	Instruction manual/booklet	Read the user documentation before you perform this task or action.

The following labels are used in the machine to identify and categorize the level of the seriousness of hazard:

Label	Type	Description
	WARNING	General warning sign.
	WARNING	Risk of electric shock. Hazardous electrical parts inside. Do not remove cover.
	CAUTION	Hot part or hot surface. Risk of burned fingers when handling the parts, do not touch.
	CAUTION	Crushing of hands.
	WARNING	Shock hazard. Disconnect all power sources before servicing. For authorized service personnel only.
	WARNING	High touch current. Risk of electrical shock Connect to earth before connecting the power supply. Refer to installation instructions, before operating the equipment.
	WARNING	Protective Earth (PE) terminal which is intended for connection to an external conductor for protection against an electric shock in case of a fault, or the terminal of a protective earth (ground) electrode.
	WARNING	Electricity: Main connection for protective earth.
	WARNING	Electricity: Main switch of the equipment.
Label	Type	Description
	PROHIBITED	Do not walk or stand here.

Label	Type	Description
 <p>Optical radiation emission Category 2 (EN 12198)</p>	WARNING	<ol style="list-style-type: none"> Warning: Hot surface. Take care to avoid contact with a hot surface. Warning: Optical radiation. Take care to avoid injury to eyes and skin when in the vicinity of optical radiation. Take precautionary actions as described in this document. Warning: Electricity. Hazardous electrical voltage inside. Do not remove cover. <p>Translation: Optical radiation emission Category 2</p>
 <p>Warning: Moving Gantry</p> <p>Avertissement: Portique mobile Waarschuwing: Bewegende brug Achtung! Brücke bewegt sich! Attenzione: Testata scorrevole in movimento Aviso: Mecanismo ou braço em movimento 警告: 可動式ガントリー 警告: 支架为可移动式 경고: 가동식 갠트리</p>	WARNING	<p>General warning. Moving gantry. Stay clear.</p>
	CAUTION	<p>Warning: Optical radiation. Read the user documentation before you perform this task or action. Translation: Avoid looking directly at lamps. Optical radiation according EN 12198 Category 2. Special restrictions and protective measures are essential when the machine is used in the workplace. Wear eye-wear, gloves and long sleeves when using this printer. The type of eye protection and gloves are prescribed in this document.</p>

Persons for Machinery Directive

- Instructed person**

This User Documentation describes safeguards for the protection of an instructed person. Instructed person is a term applied to persons who have been instructed and trained by a skilled person, or who are supervised by a skilled person, to identify energy sources that may cause pain and to take precautions to avoid unintentional contact with or exposure to those energy sources.

Power source



WARNING

- **Put the power plug directly into a power outlet that has the same configuration as the plug. The use of an adapter can result in an inadequate power supply. If a proper power outlet is not available, ask a qualified electrician to carry out the installation.**
- **This machine has two power inlets. Do not insert both power cables in one phase group.**



IMPORTANT

- Consult your authorized service representative before you connect other equipment to the same power outlet.
- Do not connect the machine to a mains voltage or frequency which differs from the value stated on the power marking label.



NOTE

- When a connection to a different mains voltage is required, contact your authorized service representative.

Power cord



WARNING

- Do not scratch, abrade, heat, twist, bend, or place a heavy object on the power cord or cause any other damage to it. The use of a damaged power cord (e.g. exposed core wire or broken wire) could result in an electrical shock, fire or malfunction of the machine. When you find any of these conditions, immediately turn OFF the power switch and unplug the power cord from the power outlet. Then call your authorized service representative.
 - Do not use a multiple outlet adapter or an extension lead. Contact your authorized service representative if an extension lead is required. The use of an extension cord may result in fire or electrical shock.
 - Do not use an extension cord to connect the machine.
 - Do not use any power cord other than the one provided. Never use the power cord with any other electrical device.
 - Use only a power cord that is fitted with a protective earth conductor.
 - Do not route the power cords in such a way that they can be stepped on or tripped over.
-

Power plug



WARNING

- If the machine is connected via a wall socket, place the machine close to a wall socket that is easily accessible. The power plug serves as a disconnecting device.
-

Grounding



WARNING

- Connect the power cord to a power outlet that is equipped with a protective earthing (PE) terminal.
 - This equipment is not designed for connection to an IT power system. An IT power system is a voltage network in which the neutral wire is not connected to earth.
-

Network cable



WARNING

- Only use a screened network cable to connect the machine to the network.
-

Installation

**WARNING**

- The machine may only be transported, assembled, installed and repaired by an authorized service representative.
 - The installation of accessories and options not permitted for the machines may constitute a violation of the Safety Regulations and Directives, and may also damage the machine.
 - Consult your authorized service representative for details on which accessories and options are permitted for the machine.
 - Only connect products which meet the national and international product safety and radio frequency interference standards.
 - Only use cables as specified by the manufacturer.
 - Place the machine on a horizontally level surface of sufficient support.
 - Do not place the machine in a location that is subject to vibrations and shocks.
 - Do not use flammable sprays, liquids or gases near the product this can cause fire.
-

Space requirements and operation precautions

**WARNING**

- Do not place the machine in rooms which are too small and insufficiently ventilated. See the Product Safety Data Sheet of the machine for the ventilation requirements.
-

**IMPORTANT**

- Do not obstruct the operating and service clearance areas in any way.
-

Operation

**WARNING**

- Do not lean, lie or stand on any part of the machine, including parts that can be pulled outwards (e.g. media drawers).
 - Read the User Documentation carefully before operating the machine. If you do not understand something in the User Documentation, please contact your authorized service representative.
 - Before you start to work with the machine, familiarize yourself with the locations and operation of the emergency stop switches.
 - Do not work with unprotected long hair or with loosely hanging items of clothing (e.g. ties, sleeves, and scarves) and jewelry such as necklaces, bracelets and rings. These can catch drive mechanisms or moving parts of the machine and cause injury.
 - Make sure that no objects (e.g. jewelry chains, paper clips, coins) or liquids get into the interior of the machine. Do not place containers with fluid (e.g. drinking bottles, glasses, cups or vases) on top or in the immediate vicinity of the machine.
 - If you operate the machine remotely, make sure that nobody is working on the machine.
 - Disconnecting the product from the mains-supply network (unplug, power-switch) might result in system-damage.
-



CAUTION

- This equipment is not suitable for use in locations where children are likely to be present.
 - The printing system may not be operated by persons under the influence of alcohol or drugs, or by persons taking certain types of medication, such as psychotropic drugs.
-

Disassemble and modification



WARNING

- Do not remove covers and panels that are fixed to the machine. Some machines have an electrical component or a laser beam source inside that could cause an electrical shock or injuries.
 - Do not modify the machine, because this can cause a fire, an electrical shock, a malfunction or injuries.
 - Do not carry out maintenance activities on other components and maintenance materials than the components and materials that are mentioned in the User Documentation.
 - Only instructed and/or skilled persons are allowed to maintain the machine, to avoid any risk and/or jeopardize given warranties.
 - Do not bridge or disable any safety interlock devices.
-



CAUTION

- Do not open any door when the machine is starting up or running, unless the control panel displays a message that asks you to open one or more doors.
 - Do not bridge any circuit breakers or fuses.
-

Repair



CAUTION

- Do not open the service areas. Opening a service area without authorization and improperly effected repairs may put operators at considerable risk.
 - Repairs to the machine must only be carried out by authorized service representatives. Access to locked areas and areas that can only be opened with special tools is reserved for authorized service representatives.
-

Moving the machine



WARNING

- Make sure that if the machine has to be moved, this is done by properly skilled person(s) who have received adequate instructions.
-

Actions in response to troubles

**WARNING**

- Immediately turn OFF the power switch and unplug the power cord from the power outlet when a piece of metal, water or any other similar foreign matter gets inside the machine. Then call your authorized service representative.
 - Immediately stop using the machine when the machine becomes excessively hot, emits smoke, or produces unusual odors or noises. Immediately turn OFF the power switch and unplug the power cord from the power outlet. Then call your authorized service representative.
 - In emergency situations, stop the machine immediately using an emergency stop switch.
 - In the event of damage to the covers, power cable or operating elements, or penetration of fluids or foreign bodies, contact your authorized service representative.
-

**CAUTION**

- Some areas inside the machine become hot. Do not touch the locations which are labeled with the "CAUTION HOT" symbol . Touching these areas can cause injuries.
-

Consumables, supplies and maintenance materials

**WARNING**

- Do not throw toner or ink, toner or ink containing parts or contaminated parts, into an open flame.
 - Do not leave toner or ink, containing parts or contaminated parts, within reach of children.
 - Store consumables, supplies and maintenance materials away from containers for food and drink.
 - Be careful when handling fluids. Clean up spilled fluids immediately, to minimize the risk of slipping and serious injuries.
-

**CAUTION**

- Only use the materials the manufacturer recommends and that are developed for the machine. Materials that have not been approved by the manufacturer may result in failure of the machine.
 - Use maintenance materials and other materials for their intended purpose only.
 - Ink polluted gloves and uncured printed media are considered chemical waste and should be disposed according to local regulations.
 - Do not place any liquids on the machine.
 - Curing of media of the Océ supported media-list is tested and considered sufficient under standard conditions. For curing of custom media see the user manual.
 - Waste of consumables must not be disposed together with household rubbish. Do not allow the product to reach the sewage system. Dispose of waste of consumables, supplies and maintenance materials and its packaging containing residues according to all federal, state and local applicable regulations.
-

UV ink



CAUTION

- UV inks and flush liquids can be harmful if not properly handled. Follow always the Safety Data Sheets (SDS) guidelines carefully in order to ensure maximum safety.
 - Avoid skin contact with ink and uncured printed media.
 - Wear specified safety glasses when handling inks or maintenance materials.
 - Wear gloves when contact with ink or maintenance materials is possible. Follow the ink related Safety Data Sheets (SDS) guidelines carefully in order to ensure maximum safety. For example use Ansell Microflex 93-260 gloves, which offer a protection against UV inks and flush liquids up to one hour. Pollution with other chemicals can shorten the protection time against UV inks and flush liquids.
 - Do not reuse single-use gloves.
 - Do not handle prints without gloves if the ink is not properly cured.
 - If ink contacts your skin: clean immediately with soap and water. Do not use alcohol or other solvents.
 - If ink contacts your eye(s) flush with water, consult the Safety Data Sheet (SDS) and contact a doctor.
 - Inks are not suitable for food-related or children-related applications (e.g. plates, toys).
 - Always measure the thickness of the media in use and set the print carriage height correctly for that media. Avoid printing at a height greater than measured as this causes excessive emissions of UV-light and UV-ink (mist).
 - All waste containing uncured or partly cured UV ink is hazardous and must be disposed of separately according to local regulations. Do not mix ink waste with non-hazardous waste (household, office, etc.). Do not allow it to reach sewage systems or drinking water supplies. Ink waste includes maintenance pads and cloths, gloves and any other material containing uncured or partly cured UV ink. Disposal must be made according to all federal, state and local applicable regulations.
 - Waste ink must not be disposed together with household rubbish. Do not allow the ink to reach the sewage system. Dispose of waste ink and packaging containing ink residues according to all federal, state and local applicable regulations.
-

UV light (UV lamps)



CAUTION

- Be aware that UV light is an invisible risk for eyes and skin. Superficial eye damage and burning of skin can occur with even brief exposure to UV light. Serious injuries can result from prolonged exposure, especially if unshielded. Keep a distance of at least 1 m from UV lamps when printing, to prevent eye and skin damage.
 - Skin contact with the UV lamp bulbs must be avoided. When heated, compounds from the skin can form permanent etching of the surface of the UV bulb. A contaminated bulb may fail prematurely.
 - The UV spectrum emitted by the machine consists of UVA (315–400 nm) and UVB (280 – 315 nm) light. Wear UV safety glasses (goggles) with side shields and lenses that block UVA and UVB light (e.g. UVEX safety spectacles CBR 65).
 - Wear appropriate clothing that protects the skin for UV light. Gloves and long-sleeved work clothes are essential to reduce skins exposure to UV light emission.
 - UV lamps operate at high temperature. Never touch these lamps in operation. Let the lamps cool for a minimum of five minutes before attempting any maintenance.
 - Use extreme care in handling the UV lamp bulbs. These UV bulbs contain a small amount of mercury (Hg) which is toxic. Therefore, if bulbs are broken, care should be taken to clean up the spill immediately, and then dispose of according local regulations concerning mercury disposal.
 - Avoid staring directly into the UV lamp.
 - As a UV lamp warms up, it briefly passes through a section of the light spectrum which excites oxygen molecules enough to create ozone. Once a UV lamp has completely warmed up, only very minute amounts of ozone are present. A high concentration of ozone can cause irritation, headaches or nausea. Provide adequate ventilation as indicated in the related Product Safety Data Sheet (PSDS) of the printer.
-

Disposal of parts



WARNING

- All parts are produced according to the sustainability policy of Océ. You can discard all used parts into a common dustbin, or follow your local or national sustainability and waste disposal procedures.
-

Liquid Crystal Display (LCD)



CAUTION

- Do not touch or ingest fluids from a broken Liquid Crystal Display (LCD). When clothes or skin come into contact with the fluid, immediately clean the clothes and skin with soap and water. After eye contact, immediately rinse the eyes with a washing lotion for at least 15 minutes and consult a physician.
 - Do not rub, press or touch the (LCD) display surface with hard material, because the polarizer at the surface can be easily scratched. The LCD module can get damaged when you drop, pinch too hard or punch the module, as it is made of glass. When glass breaks, be careful you do not get injured by pieces of glass. Then call Customer Service.
-

Flush

Flush Care and Storage

A small bottle (125ml) is supplied with the printer accessory kit. Use it only to hold flush. Tip: before you begin printhead swabbing or cleaning the AMS, fill the bottle and place several swabs into it so they are soaked in flush and ready to use.

Before first use, proceed as follows: Label this bottle as "Flush", add the actual date of receipt of the bottle and the date of expiry (two years after receipt).



CAUTION

Discard the bottle if it shows any sign of wear or physical damage (cracking or leaking) or at expiry.

Flush must not be exposed to air for long periods. Always store flush in a sealed container. Flush has a recommended shelf life of one year. Discard it after one year has passed.

Flush is a solvent and should not be splashed or sprayed around sensitive areas such as the electronics of the printheads (when cleaning printheads make sure it is only placed on the nozzles and does not move up the sides).

UV Curing System

Introduction

Lamp Replacement

Replace both lamp bulbs after 500 hours of use to help ensure that the ink on prints is fully cured.

Personal Safety



CAUTION

Warning for Seated Individuals: UV emissions are highest at a height of 90 cm (35 inches) above the floor and increase significantly the closer you are to the lamp. This can be an issue for individuals seated near the printer.

Remove all chairs within 5 meters (16 feet) of the printer.

Safety Interlock System

Introduction

The printer has three Emergency-Stop buttons. The Maintenance Station drawer is part of the safety interlock system. A beacon light indicates the status of the safety system and the printer.

Components of the Interlock System

Emergency Stop Buttons:

These are located on the Operator Control Station, and on each end of the Gantry. Activating an Emergency-Stop button stops all printer motion and turns off the UV curing system.

To re-activate the printer after you press an Emergency Stop button, turn the button counter-clockwise. Upon release of the button, no motion can be initiated without acknowledgment of the Operator from the Control Station.

Maintenance Station Interlock Function:

The Maintenance Station is located under the carriage and provides access to perform Printhead Maintenance and swab printheads. Carriage and Gantry motion motors are disabled and UV lamps are turned off (if they were On), when the station drawer is open. The Interlock system is automatically reset when the drawer is closed.

Beacon Light Status

A green beacon light is mounted to the top surface of the printer carriage. The purpose of this light is to indicate basic printer status to the operator.

Beacon off: indicates the printer can be approached without caution. The machine cannot initiate movement since the interlock Safety System has disabled all motion and hazardous hardware.

Beacon on: indicates the printer is powered up and ready to initiate motion. This tells an operator to approach the machine with caution, because it can initiate motion at any moment.

Safety Awareness

Introduction

This section contains two sets of principles that must be followed to assure maximum safety when operating your Océ Arizona printer. The first set uses negative examples to show you things to avoid in order to prevent injury to the operator. The second set of principles illustrates some of the residual risks that are inherent in the operation of the printer. These are situations or physical aspects of the printer that may present a potential danger to the operator, but would compromise the capabilities of the printer if changed. Therefore, they are pointed out as a precaution the operator must be aware of when using the printer.



IMPORTANT

The photos in the following table illustrate situations that must be avoided when operating your printer. Some of the labels in the pictures may look different on your printer.

Situations and Actions to Avoid

How NOT to use the printer

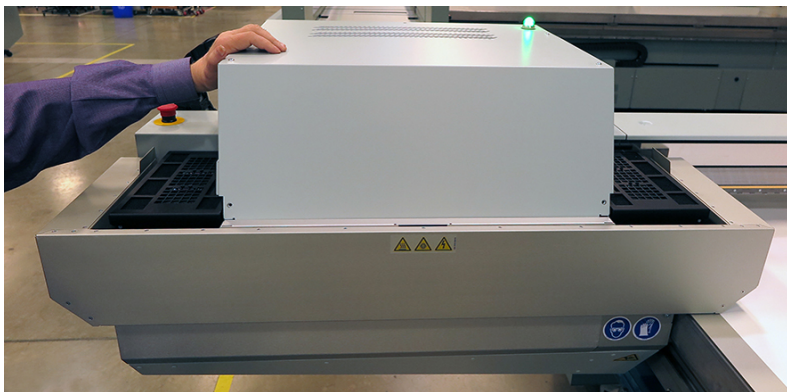
Avoid these Situations For Your Personal Safety	
 <p>[1] Keep the table clear</p>	<p>Do not place your hand in the carriage pathway when printer power is on. Do not leave any objects on the table printing surface, except for media that you will print on. Also make sure the media is 48 mm (1.89 inches) or less in thickness.</p>
 <p>[2] Avoid Carriage Movement</p>	<p>Do not push or force the carriage to move manually if it is already in motion. If you do move the carriage, a Motion Error message will display and you will have to use the mouse to click Reset on the user interface LCD display.</p>

Avoid these Situations For Your Personal Safety



[3] Do not push gantry

Do not push or force the gantry to move manually if it is already in motion. If you do move the gantry, a Motion Error message will display and you will have to use the mouse to click Reset on the user interface LCD display.



[4] Hot UV Lamps

When the Maintenance Station is open to perform printhead maintenance, do not touch the UV lamp assembly as it can be hot. Also be aware that the carriage will move up or down when the Raise Carriage switch is pushed.

Avoid these Situations For Your Personal Safety



[5] Carriage Crush Hazard

Movement of the carriage up and down may be a crush hazard. Do not rest your hands in this area during daily print-head maintenance as this process causes the carriage to move up and down.



[6] IGUS Hazard

Avoid placing fingers, hands or other objects in the IGUS track unless power is off and the printer is locked out.

Avoid these Situations For Your Personal Safety	
	<p>Avoid printing at a height greater than measured as this causes excessive emissions of UV light and ink mist. Keep a distance of at least 1 m (3 ft.) to the UV light when printing. Avoid looking at the UV lamps, especially if you are seated at the same level as the carriage. Do not sit within 5 meters (17 feet) of the carriage path. Also do not touch the UV lamp assembly or the surrounding guard as they will be hot and may result in burns of the skin.</p>
<p>[7] UV Lamp Hazard</p>	



Residual Safety Risks

Your Océ Arizona printer is engineered to minimize machine components and operating procedures that may compromise operator safety. However, in order to maintain some machine operations and functionality, certain compromises are required. The following table documents some of these residual hazards. By making the operator aware of the potential risks, we hope to ensure maximum safety in the operation of this printer.

Caution: there may be a time lag between when a print job is issued and when the gantry movement actually begins as the UV lamps must warm up first. Movement can start many minutes after a print job is sent.

Arizona Printer Residual Risks

Residual Risk Area	Hazard
<p>A high risk crushing hazard is created by the movement of the carriage and gantry supports. Keep hands away from this area unless the printer power is off.</p>	 <p>[8] Carriage guard and 45° guard on Gantry Supports</p>

Residual Risk Area	Hazard
<p>A crushing hazard is created by the movement of the carriage along gantry rails. Keep hands away from this area unless the printer power is off.</p>	 <p>[9] Carriage Guard and Gantry Rails</p>
<p>A high risk crushing/pinch hazard is created by the table and the gantry.</p>	 <p>[10] Table/Gantry Pinch hazard</p>
<p>A high risk crushing/pinch hazard is created by the table and the carriage.</p>	 <p>[11] Table/Carriage Pinch Hazard</p>

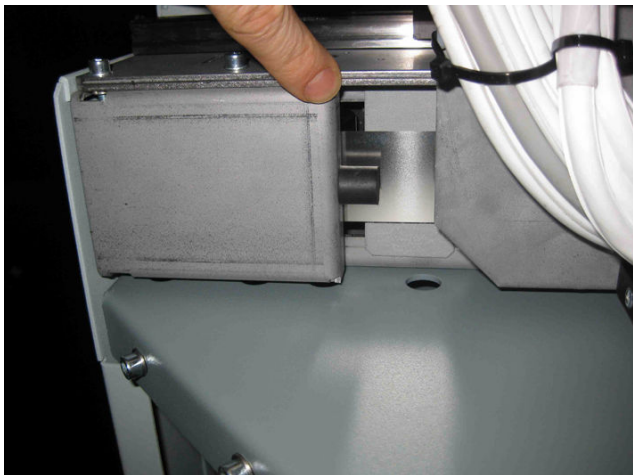
Residual Risk Area	Hazard
<p>A high risk crushing/ pinch hazard is created by the carriage and the gantry when the Z-Axis is moving (carriage moves up or down).</p>	 <p>[12] Carriage Vertical Movement Pinch Hazard</p>
<p>A high risk shearing hazard is created by the gantry and the gantry rail. This photo shows the view from the bottom. Do not place fingers or hands in this area.</p>	 <p>[13] Gantry Shear Hazard</p>

Residual Risk Area	Hazard
<p>A high risk shearing hazard is created by the gantry and the gantry rail. This photo shows another view from the bottom. Do not place fingers or hands in this area.</p>	 <p>[14] Gantry Shear Hazard</p>
<p>A high risk shearing hazard is created by the carriage and the gantry frame.</p>	 <p>[15] Gantry Frame Shear Hazard</p>

Residual Risk Area	Hazard
<p>Entanglement hazard A medium risk of finger or material entanglement is created by the web assembly (IGUS track).</p>	 <p>[16] IGUS Impact Hazard</p>
<p>A medium risk impact hazard is created by the carriage when cycling from left to right.</p>	 <p>[17] Carriage Impact Hazard</p>
<p>Heat hazard: the UV lamp assembly and the surrounding carriage guard can be hot. The Carriage Guard is an aluminum fence around the perimeter of the carriage. If the guard is not properly seated all gantry and carriage motion is disabled, UV Lamps are switched Off. After re-seating the Carriage Guard, the Operator must provide acknowledgment to re-enable functioning.</p>	 <p>[18] UV Lamp Heat Hazard</p>

Roll Media Safety Awareness

Introduction

This section contains two sets of principles that must be followed to assure maximum safety when operating the Roll Media Option (RMO) for your Arizona printer. The first image uses a negative example to show you a situation to avoid in order to prevent injury to the operator. The following images illustrate some of the residual risks that are inherent in the operation of the printer. These are situations or physical aspects of the printer that may present a potential danger to the operator, but would compromise the capabilities of the printer if changed. Therefore, they are pointed out as a precaution the operator must be aware of when using the printer with the Media Roll Option.

Situation and Action to Avoid

How NOT to use the Roll Media Option

Avoid these Situations For Your Personal Safety

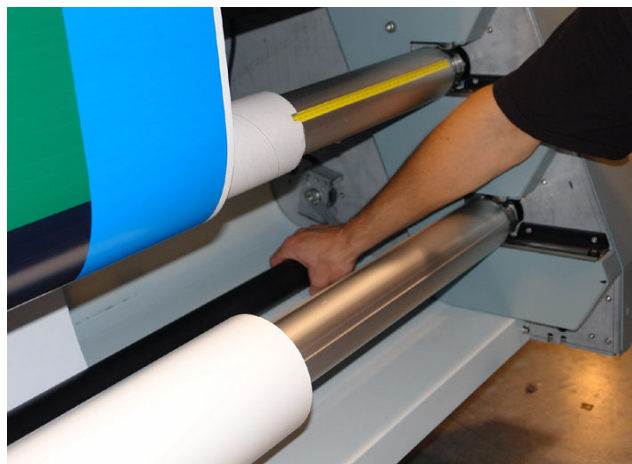

Do not place your hands near any of the media shafts or the media tension bar when the printer is printing.

Residual Safety Risks



IMPORTANT

The photos in the following table illustrate residual risks that must be avoided when operating the RMO with your printer.

The Roll Media Option is engineered to minimize machine components and operating procedures that may compromise operator safety. However, in order to maintain some machine operations and functionality, certain compromises are required. The following table documents some of these residual hazards. By making the operator aware of the potential risks, we hope to ensure maximum safety in the operation of this printer.

RMO Residual Risks

Crushing/Shear Hazard



Do not place your hand near the shaft drive motors when the printer is printing or when the dual foot controls are pressed.

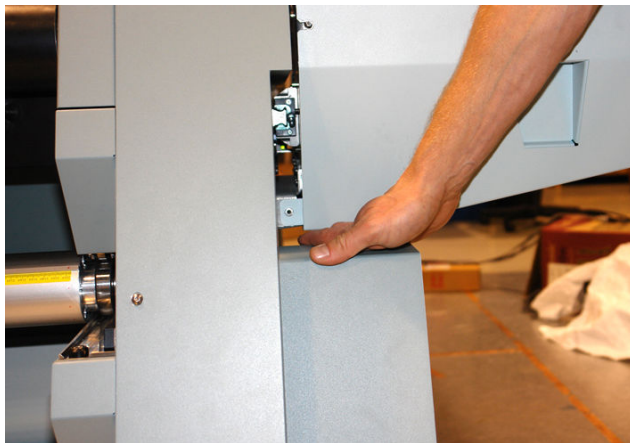

Do not place your hand on the Media Roll motor enclosure when the green beacon light is On as the gantry may move at any time.

Chapter 4

How to Navigate the User Interface

Operator Interface Hardware

Introduction

The Operator interacts with printer components to print, maintain, and monitor the state of the printer. This section identifies and explains the functions of the hardware.

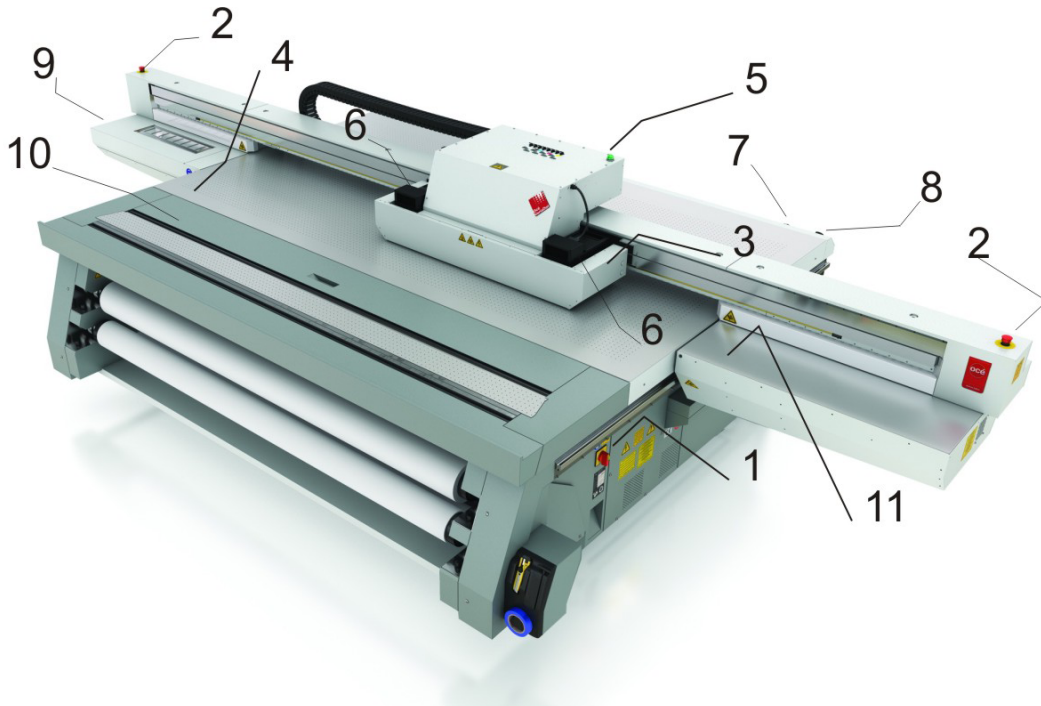

[19] Printer Hardware

Operator Interface Components

Hardware Interface Components

Component	Function
1) Main Power Switch	Turns the printer On and Off.
2) Emergency Stops	Emergency stop buttons can shut down all motion and hazardous systems. There are three E-stops, one on the podium stand, and one on each end of the gantry.
3) Carriage Guard	Protects the Operator from exposure to UV light and stops all motion if dislodged by an obstacle.
4) Registration Pins	Allow the operator to register media by placing it against the pins. Registration pin operation can be set at the user interface to work in either manual or automated mode. Pins can be enabled or disabled individually.
5) Printer Status Beacon	Indicates printer status. See Chapter 3 for details.
6) UV Lamps	UV light is used to cure the ink.
7) Vacuum Gauge	Displays the strength of the table vacuum system. If it reads less than 10"Hg, check for vacuum leaks.

Component	Function
8) Print Button	Starts the current print job.
9) Maintenance Station	Designated area for cleaning the printheads and the underside of the carriage.
10) Vacuum Zone Control Handles (image 2) 10) on image 1 shows optional RMO	Five vacuum zone control handles determine if vacuum zones 2 to 6 on the printer table are active when the vacuum pump is switched on. Zone 1 is always on so it has no control handle. The zones on the Océ Arizona 1200 XT model are different (see Chapter 6 for details).
11) Automatic Maintenance Station (optional)	Provides a station where printheads can be parked on a vacuum system that pulls debris and particulate matter from the nozzles.
12) Ink Filters	Ink filters are behind a door under the ink bags. The filters remove unwanted particulate matter from the ink.
(13) Coolant Bottle	Provides coolant to maintain correct temperature of the ink in the printheads.
(14) Vacuum Table Foot Switch	Toggles the pump that turns the table vacuum on/off. Vacuum must be on prior to starting a print.
(15) Ink Bay	There are two ink bays: the Primary bay contains CMYK ink and the coolant bottle; the Secondary bay holds any additional supported color channels.

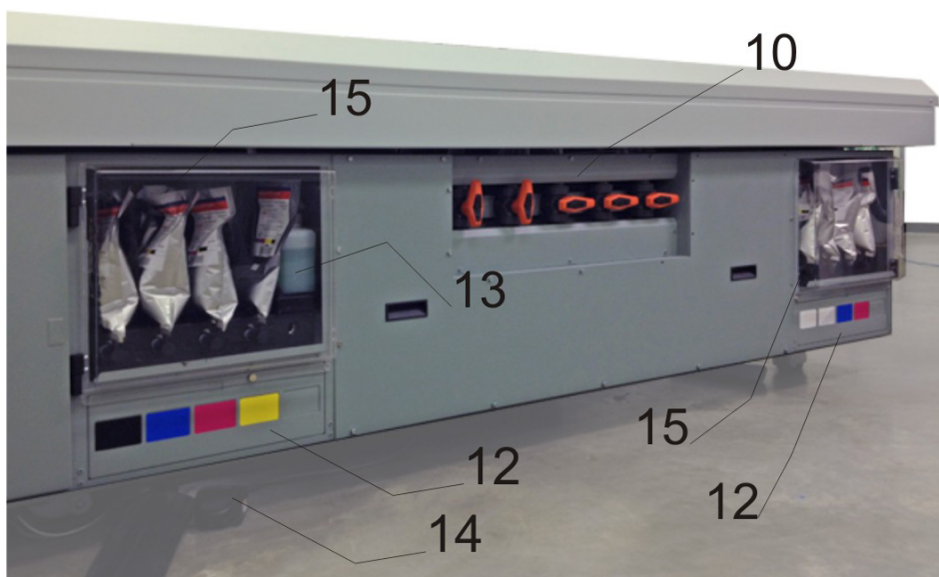

[20] Ink Bays and Vacuum Zone Control Handles

Printer Interface Software

Introduction

The printer software is displayed on the LCD monitor. The interface has seven main modules that are accessed by tabs located at the bottom of the display. Click on these tabs to access the modules. Print Job Control is the default module displayed when the software has finished loading after the printer is switched on or reset.

The Print Job Control display is divided into functional and status areas. The functional areas support all operator input necessary to operate, maintain and service the printer. The status areas are used to report printer status.

Onscreen Keyboard & Numeric Keypad

A mouse is used as the input device to navigate the menu-based interface. For operations that require operator input, the mouse is used to select either numeric characters from a virtual keypad or alphanumeric characters from a virtual keyboard. These virtual input screens are displayed on the interface LCD monitor when data entry is required.

Virtual Keypad

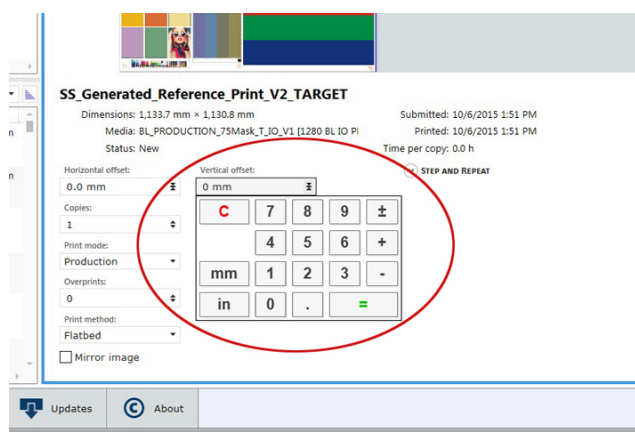

Operator Interface Module Tabs

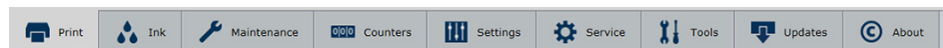

Interface Modules Tabs

Component	Function
Print Job Control (Print tab)	Provides management of all aspects of working with print jobs. It also controls some features of the printer and provides access to Roll Media print controls (if that option is installed).
Ink System (Ink tab)	Provides various statistics about the inks. In the case of expired ink, the ink system is disabled. It can be re-set in the module. You can bypass the expired state within a 30 day grace period (for example, if you know you don't need that color in the current print job) but it is in your best interest to replace any expired ink bags.

Component	Function
Maintenance (Maintenance tab)	<p>Displays maintenance tasks you must perform and indicates when to do them. After you perform each task, the printer will record that the task was completed and then calculate when the task must be performed again. At that time you will be reminded that the particular maintenance task is due.</p> <p>Provides access to Manual Maintenance where you can select which ink channels will be purged in preparation for cleaning the printheads with a suction device.</p> <p>Provides access to UV lamp bulb change screen. Also provides counters for the UV lamp bulbs use and the option to reset the time after a bulb is changed.</p>
Counters (Counters Tab)	<p>Provides information about the amount of ink consumed, the amount of media printed, total printing time, and the number of print jobs started.</p>
Printer Settings (Settings tab)	<p>Displays information about, and also allows you to change various aspects of the printer: Date and Time, Network Connections, User Interface, Printer Settings, and Roll Media Settings (if that option is installed).</p>
Service and Diagnostics (Service Tab)	<p>This area is reserved for use by trained field service technicians only.</p>
Tools (Tools tab)	<p>Provides access to the Shutdown, Special prints, and Generate Log files.</p>
Software Updates (Update tab)	<p>Allows you to update the printer to the latest version of software.</p>

Print Job Control Module

Introduction

Print Job Control is the first module displayed when the printer software is loaded. From this module you can manage all aspects of working with print jobs and also control many features of the printer. The table "Job Control Panels" documents the numbered call-out and the rest of this section explains each of these areas in more detail.

The Print Job Control display is divided into functional and status areas. The functional areas support all operator input necessary to operate, maintain and service the printer. The status areas are used to report image and printer status.

Print Job Control

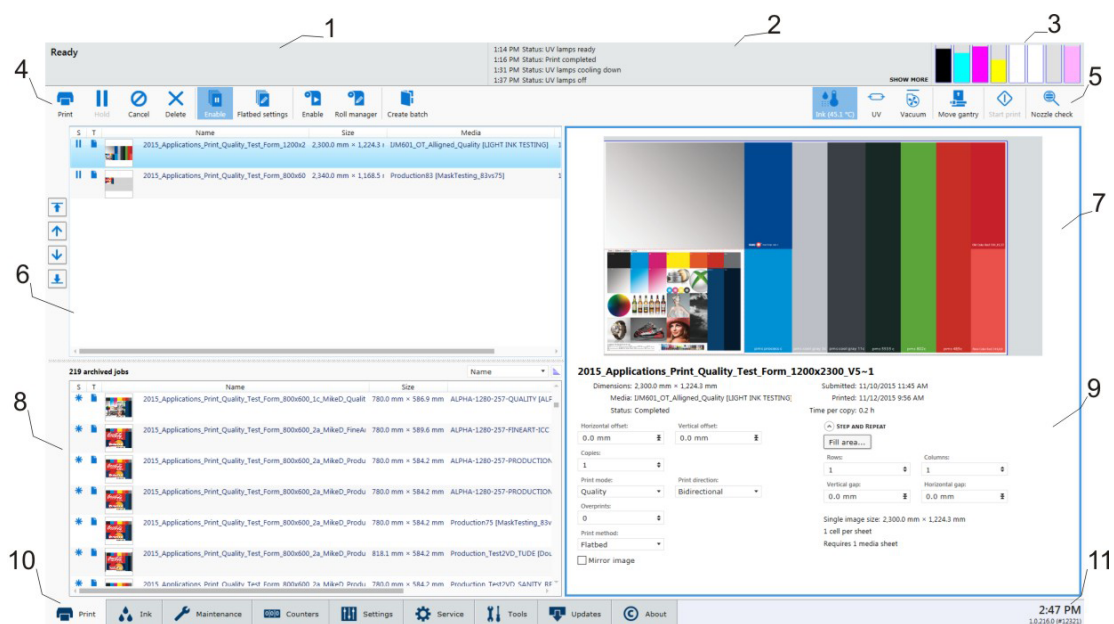

Components of the Print Job Control Module

Job Control Panels

Component	Function
1) Job and Printer Status	Displays the status and progress of print jobs.
2) Printer Messages Panel	Displays the last four lines of the log - click on the "show more" link to see more of the log.
3) Ink System Status	Ink System Status icon - click to view an ink status report.
4) Command Toolbar left	Displays icons for actions related to the print jobs and control of the printer.
5) Command Toolbar right	Displays icons for ink temperature, lamp control, start print jobs, and print a nozzle check.
6) Active Jobs List	Displays a list of all Active print jobs.

Component	Function
7) Job Placement Preview	Displays the selected print job with a preview that shows the placement of that job on the printer.
8) Archived Jobs	Displays a list of all archived print jobs (they will remain in the list until deleted).
9) Job Information and Parameters panel.	This panel shows the parameters of the currently selected print job and also allows changes to the parameters associated with that job.
10) Interface Tabs	Use these tabs to select the different modules of the printer user interface.
11) Software Version Number and Image Upload Progress	Displays the current installed version of the printer software and the current time.

Job Control Components Explained

1) Job and Printer Status Panel

The job status panel is in the top left corner of the display screen. It shows information about the current state of the printer or job activities.

- Printer Status
- Job name currently printing
- Total copies, number of printed copies and copy progress
- Overprint progress and number of overprints if more than zero

All incoming jobs go directly into the active job list or job queue.

Selecting a job in the list highlights the job and updates the job information area.

The job information area contains offsets, print mode information, number of copies and overprints, and the name of the ONYX profile used. The image to be printed is also displayed.

Jobs can be moved up or down in the list and can either be printed, held, canceled, or deleted.

2) Printer Messages (or Log) Panel

The printer status panel is in the top right corner of the display. It shows the last four lines of the printer log that contains printer errors, warnings, and information messages. To see more of the log, click on the "show more" link to bring up a new window that allows you to scroll through the log.

3) Ink Status

Ink System Status. Click the icon to open an ink system status dialog that displays ink-related information. This includes, for each color of ink: an expiry date, ink type code, ink bag status, fill status (whether ink fill is active), and whether the reservoir is full. The dialog also shows the current printhead temperature, the meniscus vacuum level, and the purge pressure.

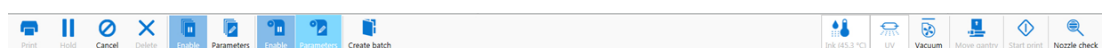

4 & 5) Command Toolbar

The toolbar contains icons that allow you to interact with the printer (icons are listed in the table below in the order they are displayed on the command toolbar). Note that some of the icons have a checked and unchecked state with a different appearance of the icon image to reflect their state.



[21] Command Toolbar

Command Toolbar Icons Explained	
Print job	<p>This command can do the following actions depending on context:</p> <ul style="list-style-type: none"> • Activates a selected inactive job by moving it to the active list. • Un-holds a held job. • Un-holds an job that had an error currently.
Hold job	<p>The command can do following actions depending on context:</p> <ul style="list-style-type: none"> • Puts an active job on hold. • Waits until the printer finishes a currently printing copy and puts the job on hold.
Cancel job	<p>The command can do following actions depending on context:</p> <ul style="list-style-type: none"> • Deactivates a selected active job by moving it to the inactive list. Note that Special Prints will not move to the inactive list. • Cancels a currently printing job and moves it to the inactive list. Note that the first click cancels the print, but the carriage will continue to apply curing passes so that the ink cures properly. A second click terminates the print job immediately.
Delete job	<p>Deletes a job from the printer. However, you cannot delete a job that is currently printing.</p>
Flatbed Enable	<p>Enables or disables the flatbed print queue. This must be selected to enable flatbed printing when the printer is booted or after re-setting the printer due to an error.</p>
Flatbed Settings	<p>A dialog window automatically appears when confirmation is required. If it is closed before you select Confirm, it can be reopened by clicking on this button.</p> <p>Media Parameters</p> <p>Enter or confirm the thickness of the media. The printer will automatically adjust the carriage height to create the proper print gap for the specified media thickness. Media thickness confirmation is required only for the first copy of a print job, unless it is changed during printing. If the media thickness value is changed while printing, confirmation is requested before printing the next copy.</p> <p>Lamp Power Control</p> <p>Allows the operator to control the power output of each UV lamp independently. To extend lamp life, use the lowest setting that provides adequate curing for a particular media.</p> <p>Leading and Trailing Edge are relative to the direction of carriage travel. To enable or disable this setting, see the User Interface section of the Settings page "Tie lamp controls together". When enabled, this feature automatically matches the power of the trailing UV lamp, when power of the leading UV lamp changes. It is still possible to adjust the power of the trailing UV lamp individually, when this setting is not enabled.</p>

Roll enable	<p>Enables or disables the Roll Media Option print queue (this allows you check media parameters before the job actually prints). Roll media print jobs will not print unless this icon is selected.</p> <p> NOTE Roll media print jobs do not require user actions to start the print job once Roll module is initialized (see Roll Media Manager in the RMO) If this icon is selected, and the job status is not on Hold, roll media print jobs will start automatically when the printer receives the job.</p>
Roll Manager	<p>The Roll Manager allows the operator to load and unload media and to initialize the Roll module so that the tension on the roll media is set and the roll is ready to be printed on.</p>
Create Batch	<p>In Batch Mode Operation individual print jobs are sent from the RIP to the printer, and then combined on the printer to create a batch job for flatbed printing. There are two types of batch mode jobs: Composite and Collated. In a Composite batch all images are printed on a single piece of media without interruption. Composite batch mode can be used to efficiently print more than three data layers and/or mix print modes for a batch job. A Collated batch prints a set of individual print jobs on individual pieces of media, and then repeats the number of copies of the set, as required. The gantry moves to the park position between each print job, the media is changed, and media thickness confirmation and pushing the start button is required to continue printing the next copy. Refer to Customer Application Bulletin 45 "Batch Mode Operation" on the DGS website https://dgs.oce.com for more details and examples.</p>
Ink Temperature Control	<p>This icon controls the ink heater and also displays the ink temperature. The state of the button reflects the status of the ink heater. The heater times out after two hours of inactivity (time can be changed up to four hours by a service technician). If the ink heater is turned off when the timeout period has expired, the button changes its status to unselected. The printheads must be at operating temperature (45°C / 113°F) before a job will start printing.</p> <p> NOTE If this button is flashing, it indicates an error. Click on the Ink Status button to check the ink system.</p>
UV Curing Lamp Control	<p>This icon controls the UV curing lamps. The state of the button reflects the state of the lamps. The UV lamps will timeout after 15 minutes of inactivity (time can be changed by a service technician). The lamps are extinguished when the timeout expires, and the button changes its status to unselected. If the lamps are off before the print starts, the lamps are turned on automatically and the button reflects the state accordingly.</p>
Table vacuum	<p>This icon controls the table vacuum and duplicates the function of the table vacuum foot switch. The button reflects the actual state of the table vacuum. There is an automatic timeout that will turn the table vacuum off. The actual time is set in the Settings module under Printer.</p> <p> NOTE Once turned off, vacuum cannot be turned on again for approximately 5 seconds.</p>

Move Gantry	Moves the gantry from its parked position to the center of the table.
Start	This icon can be used to start a flatbed print job (same function as the physical button on the table).
Nozzle check	<p>This icon populates the active job list with a job that prints a nozzle check pattern. The nozzle check print is used to identify nozzle dropouts that can cause banding and other print quality problems. If you don't want it at the origin point, you can place the nozzle check print where you want it to appear by moving it anywhere you wish on the current media area in the Job Placement Preview area.</p> <p> NOTE For information on how to use the nozzle check to troubleshoot nozzle dropouts, see the Printhead Maintenance section in the Maintenance chapter.</p>

6) Active Print Job List (Print Queue)

The active job list consists of a list of jobs, a job count summary on top and job order control buttons on the left. A job count summary displays total number of active jobs and number of jobs put on hold. Job order control buttons can be used to change order of jobs queued for printing. The active job list has the following features:

- All incoming jobs issued from the ONYX workflow go directly into the active job list.
- After a job is printed it automatically moves from the active to the inactive job list.
- The operator can drag and drop jobs to move them between the active and inactive job lists (except for a job that is being prepared to print).
- All the jobs are stored locally on the printer hard drive.
- Selecting a job highlights the job and updates the job information area.
- Jobs can be moved up/down in the active list using the button on the left. Jobs can either be printed, held, canceled or deleted. Jobs canceled from the active list are moved to the inactive list.
- Deleted jobs are removed from the hard drive and are no longer accessible (except for Special Prints, which cannot be deleted).
- The current job being printed can be paused or canceled. A canceled job will move from the active to the inactive print job list.

How to Manage the Appearance and Content of the Print Job List

You can control the order that columns appear on the job list, the width of each column, and also the columns that appear on the display.

1. Control the order of columns by dragging the column header to a different position.
2. Change the width of a column by clicking on the vertical line that separates column headers and dragging to the left or right.
3. Chose the columns to display by right-clicking on a column header and then click on a column name to add or remove it. Columns with a check mark will appear on the display and those with no check will not be seen.



NOTE

Columns can be set back to their original appearance by right-clicking any column head (name) and selecting **Reset to default**.

This column management can also be applied to the Inactive Print Job List (see 8) below and also to the Batch Mode job list (see Chapter 5, "Batch Mode Printing").

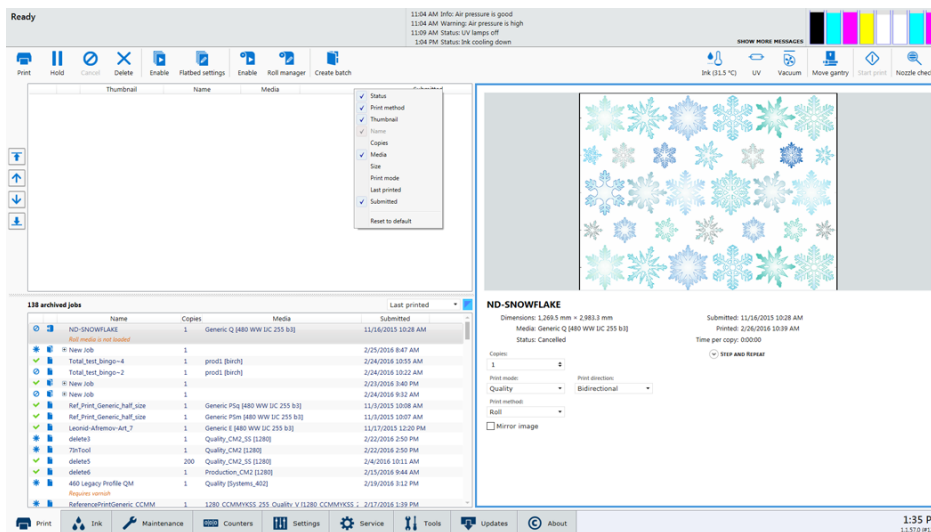

7) Job Placement Preview

The table placement preview shows the print location and a proportional representation of the image in relation to the table. The zoom button in the bottom right corner activates a popup preview window. If a preview image is not available, an appropriately sized white box is used as a placeholder, and the zoom button is not displayed.

The preview image can be positioned by dragging it around the window (this will automatically update the offsets fields).

When an image is out of bounds in the actual table area, that area in the table preview is marked in red.

When an image is out of bounds in the bleed region, that area of the table preview is marked in yellow.

Roll media print jobs will display only the middle part of the image if it does not fit in the window. They can't be repositioned by dragging in the window.

8) Inactive Print Job List (Archive List)

Inactive job list consists of a table and job count summary on top. The job count summary displays the total number of inactive jobs. The list can be sorted by clicking on the appropriate column header. The icons in the first column reflect the job type and status and can be used to sort the list. The size column is sorted by image area. Date column is sorted by a compound value of date and time. The inactive job list has the following features:

- The operator can drag and drop jobs to move them between the active and inactive job lists.
- Columns can be managed as described for the Active Print Job List in point 6 above.
- Jobs deleted from the inactive list are deleted from the hard drive.

9) Job information and parameters panel

The job information area displays only relevant job parameters of the currently selected job. For example, the Overprints field is not displayed for roll media jobs. Some of the parameters can be modified.

Offsets	To change parameter values, click on the field and this brings up an onscreen keyboard so you can click on the numbers required. You can also use Preview to drag an image to the desired position. ▶
----------------	---

Print Parameters	<p>Displays information about the print job that is currently selected:</p> <ul style="list-style-type: none"> • Copies - use the mouse to increase or decrease. • Print Mode - Print modes are selected in THRIVE or ProductionHouse. See "Print Modes Explained" below for details of each mode. • Print Direction - Bidirectional and Forward or Reverse unidirectional. • Overprints - If the Overprint count is set to greater than 0 (zero), the printer will re-print the image again, that many times, on the same piece of media.
Job Placement	<ul style="list-style-type: none"> • Origin - allows selection of either Origin A, Origin B, or Dual Origin (this is available for XT models only) • Print Method - Flatbed or Roll. • Mirror Image - Allows you to reverse the horizontal orientation. • Step and Repeat - Select the number of rows and columns to determine how many times an image will repeat on a single sheet of media.

Print Modes Explained

- **Express** mode provides fast printing but image quality depends on all nozzles jetting ink. It is best with images that do not have large areas of solid color or high saturation.
- **Production** mode allows a wide variety of printing output. As with high-speed modes on any inkjet printer, there is insufficient nozzle redundancy to produce flawless images all the time on all media. As a result, it may be necessary to print some output in Quality Mode.
- **Production Fast** mode is a more compactly printed variant of Production mode, that reduces the printing time by approximately 25% but depends on the presence of Light Cyan and Light Magenta inks in pallet to work. As a result this mode is only available when using the optional six color ink configuration (CMYKcm).
- **Production Smooth** mode is the smoothest, least textured version of all the Production print modes. As a result it can be used to produce a significant portion of output. It features twice the usual nozzle redundancy of regular Production mode, but only in Cyan and Magenta, so as with any high-speed mode on any inkjet printer, there may sometimes be insufficient nozzle redundancy to produce flawless images all the time on all media. This mode depends on the presence of an extra Cyan and Magenta ink channel, a printing technique referred to as "CM-Squared" or CM2. This mode is only available when using the optional six channel, four color ink configuration (CCMMYK).
- **Production Squared** mode can be used to produce a wide variety of printing output as along as the printhead nozzles are firing properly. Production-Squared mode has a 25% faster print speed than Production-Smooth mode but is more sensitive to nozzle outs. As with high-speed modes on any inkjet printer, there is insufficient nozzle redundancy to produce flawless images all the time on all media. As a result, it may be necessary to print some output in Production-Smooth mode or Quality mode. As is the case with Production-Smooth, this mode is also only available when using the optional six channel, four color "CM-Squared" ink configuration (CCMMYK).
- **Quality** provides excellent image quality and is suitable for a wide range of image types and looks good with most media.
- **Quality-Density** doubles the density for backlit media. For flatbed media that may warp or move slightly from the heat of the lamps, this mode provides better image registration than doing an Overprint because it is done in one gantry pass.
- **Quality-Layered** allows you to place multiple layers in one print job. It is most useful when printing with White Ink (see Chapter 9 How to Work with White Ink and Varnish). You must configure any extra layers in the ONYX software.
Note: When Quality Density or Layered mode is used, there is a pull-down menu in the Print Job module that allows you to select either Quality-Layered or Quality-Density (the menu allows you to change how it was configured in your ONYX software).
- **Quality-Matte** provides a matte finish to the entire image. This is helpful on some media such as FomeCore, GatorPlast or Styrene as a glossy image tends to have a matte line at the end of

each swath with these media. Quality-Matte resolves this issue. This mode is only available when using the optional six color ink configuration (CMYKcm), which includes Light Cyan and Light Magenta inks .

**NOTE**

Some Quality print modes are also interchangeable at the printer UI. For example, if Quality mode is specified in the submitted job, Quality-Matte or Quality-Density modes may be selected in the Print Job module of the printer UI. This changes how the job will print without resubmitting it from the workflow.

- **Fine Art** is used when details are important and speed is not an issue. It is a good choice if your image contains text or fine details and also solid colors.
- **High Definition** provides higher resolution with more detail than Fine Art, especially with very small text or fine lines.

10) Printer Interface Module Tabs

These tabs allow you to switch between different functional modules of the printer. Click on a tab to display the screen associated with each of the modules available.

11) Software Version Number

Displays the version of the currently installed printer software and the current time.

Maintenance Tasks

Introduction

Regular maintenance is very important to ensure the best image quality from your printer. In order to help you remember and maintain the proper schedule, the Maintenance Tasks module provides a list of the important tasks you must perform and indicates when you must do them. After you perform each task, click the Done button and the printer will record that the task was completed and then calculate when the task must be performed again. At that time you will be reminded that the particular maintenance task is due. It is possible to postpone the task for a short time but the printer will remind you with a message periodically until the task is completed. Although you can select Done or Postpone even if the task is not complete, it is in your best interest to follow the recommended schedule. If you do not follow the maintenance schedule, image quality will decrease and printhead replacement frequency and costs will increase.



NOTE

If you have not performed your daily Printhead Maintenance, a dialog box appears with a query to Perform or Postpone this task. If you choose to perform Printhead Maintenance the Periodic Maintenance screen will appear and the ink temperature is displayed. When the ink is at jetting temperature you can perform Printhead Maintenance.

The Importance of Printhead Maintenance

Daily printhead maintenance and ongoing care and cleaning of your printer is essential to good image quality.

- Improper or infrequent printhead maintenance is one of the main factors contributing to premature printhead failures.
- Improper printhead maintenance causes banding and reduces image quality.
- Pay attention to the conditions of the workplace environment as detailed in the Site Preparation Guide
- Use the cleaning methods and the maintenance schedule documented in this User manual, the Care and Use Poster, and the Printhead Maintenance video (you can download the poster and video from the customer support website: <https://dgs.oce.com>).

Illustration

Task	Frequency	Last performed on	Due on	Action
Clean underside of carriage. Clean automatic maintenance station. Agitate white ink bag if present.	Daily	Last performed on: 2/12/2016 10:24 AM	Due on: 2/12/2016 6:04 PM	Done
Seal print heads. Empty waste ink tray. Check coolant level.				Done
Replace UV lamp filters.	Weekly	Last performed on: 2/9/2016 9:00 AM	Due on: 2/16/2016 9:00 AM	Done
Bleed ink filter on port 0.	Every two weeks	Last performed on: 2/9/2016 9:00 AM	Due on: 2/23/2016 9:00 AM	Done
Bleed ink filter on port 1.	Every 3 bag changes	Last performed on: 10/28/2015 1:20 PM		Done
Bleed ink filter on port 2.	Every 3 bag changes	Last performed on: 10/28/2015 1:20 PM		Done
Bleed ink filter on port 3.	Every 3 bag changes	Last performed on: 1/1/2016 9:20 AM		Done
Bleed ink filter on port 5.	Every 3 bag changes	Last performed on: 10/28/2015 1:20 PM		Done
Bleed ink filter on port 6.	Every 3 bag changes	Last performed on: 2/5/2016 9:26 AM		Done
Bleed ink filter on port 7.	Every 3 bag changes	Last performed on: 2/5/2016 9:26 AM		Done
Bleed ink filter on port 8.	Every 3 bag changes	Last performed on: 1/28/2016 9:26 AM		Done
Replace ink filter on port 0 and bleed.	Every 3 bag changes	Last performed on: 2/1/2016 3:45 PM		Done
Replace ink filter on port 1 and bleed.	Every 30 L	Last performed on: 3/16/2015 5:48 PM		Done
Replace ink filter on port 2 and bleed.	Every 30 L	Last performed on: 3/16/2015 3:47 PM		Done
Replace ink filter on port 3 and bleed.	Every 30 L	Last performed on: 3/22/2015 6:29 AM		Done

45.2 °C

Maintenance Tools: Auto maintenance, Manual maintenance, Clean AMS, UV Bulb replacement, Head carriage, Ink flush.

Print Ink Maintenance Counters Settings Service Tools Updates About 2:40 PM

Counters Module

Introduction

The Counters module displays counters that are of interest to the operator. It shows counters for each color of ink and the total ink used. Some of the counters can be reset.

Counters

The screenshot shows the 'COUNTERS' module interface. It features a table with the following data:

Counter	Lifetime	Cumulative	Resettable Last reset on 8/24/2015 5:28 PM [Reset]
Prints Completed	443	439	0
Printed Area	1,710.677 m ²	1,609.593 m ²	0.000 m ²
Printing Time		142.2 h	0.0 h
Cyan		3,763 l	0.000 l
Magenta		3,369 l	0.000 l
Yellow		5,081 l	0.000 l
Black		1,969 l	0.000 l
Total Ink Consumed		14,182 l	0.000 l

The interface also includes a navigation bar at the bottom with icons for Print, Ink, Maintenance, Counters, Settings, Service, Tools, Updates, and About. The system time is 4:09 PM on 10/10/15 (171202).

Component - function table

Counters Explained

Component	Function
Lifetime Counters	These counters display a cumulative total of ink consumed or area printed over the whole life of the printer.
Resettable Counters	These counters display a cumulative total of ink consumed or area printed since the Reset button was last pressed. Time and date of last reset is displayed, if available.

Settings Module

Introduction

The Settings Module allows you to review and change the date and time, network connection settings, user interface configurations, printer settings and, if installed, the Roll Media settings.

Date and Time Settings

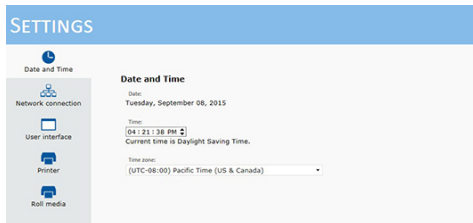

- Date - display only, cannot change the date
- Time - change the time of day, if required
- Whether Daylight Savings Time is set
- Time Zone - select the time zone for the printer location

Network Connection Settings



NOTE

Typically, DHCP is used to automatically obtain network settings. If "Use DHCP" is selected, the only thing you might want to change is the network name of the printer. The settings are displayed to troubleshoot possible network connection problems. One situation that would require changes is if your network does not use DHCP to automatically obtain network settings. In this case network settings have to be entered manually. If you don't know how to do this, bring in a network consultant to determine what the setting must be for the network (alternately, you can purchase a DHCP router for your network that will automatically supply the network settings).

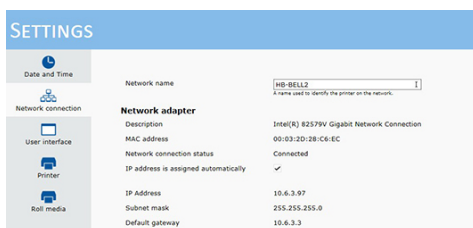

- Network Name
- Printer Description
- Network Adapter Name
- MAC Address
- Network Status
- Use DHCP
- IP Address
- Subnet Mask
- Default Gateway

**NOTE**

A network name for the printer cannot consist of numeric characters only - it must be a mix of alpha-numeric characters.

If the Printer name is changed, the printer must be restarted for the change to take effect. If any settings require a printer restart, a reminder will be displayed when that settings is selected.

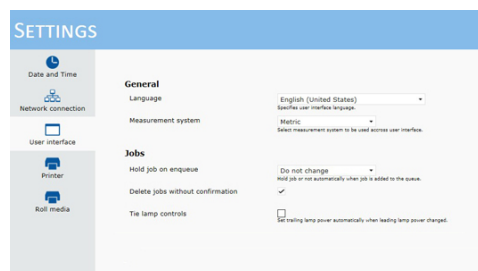
User Interface Settings**Settings Available**

The user interface allows you to change the following features:

- Language
- Measurement Units
- Hold on queue
- Delete jobs without confirmation
- Tie lamp controls

Printer Settings

Allows you to set the following:

- Underlay thickness
- Table vacuum timeout
- Ionizer bar (static suppression - On or Off)
- Beep on print
- Media registration pins behavior
- Enable/disable media registration pins
- End of swath delay

Settings Module

- Full carriage travel
- Blank space skipping
- Automatic warm-up days and time
- Weekly Maintenance Day
- Weekly Maintenance Time

Roll Module

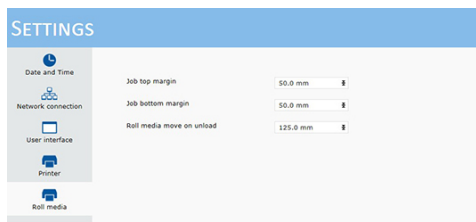

Top Margin

Specifies the distance to be left not printed above the image.

Bottom Margin

Specifies the distance to be left not printed below the image.

Media Move on Unload

Specifies the amount of media moved on unload in the selected measurement units.



NOTE

This setting icon is displayed only if the Roll Media Option is installed.

Tools and Utilities Module

Introduction

The Tools and Utilities Module has three sub-modules: Special Prints, Shutdown, and the System Logs. When you click on the Tools tab, Special Prints always appears first. Click on the other icons to access the sub-modules.

- **Special Prints** provides special prints for various purposes, such as reference, adjustment and alignment. Some are for operator use and others are for service technician use only.
- **Shutdown** provides the mechanism to properly power down the printer.
- **Generate Logs** allows the operator to generate log files for service diagnostics and troubleshooting purposes.

Tools and Utilities

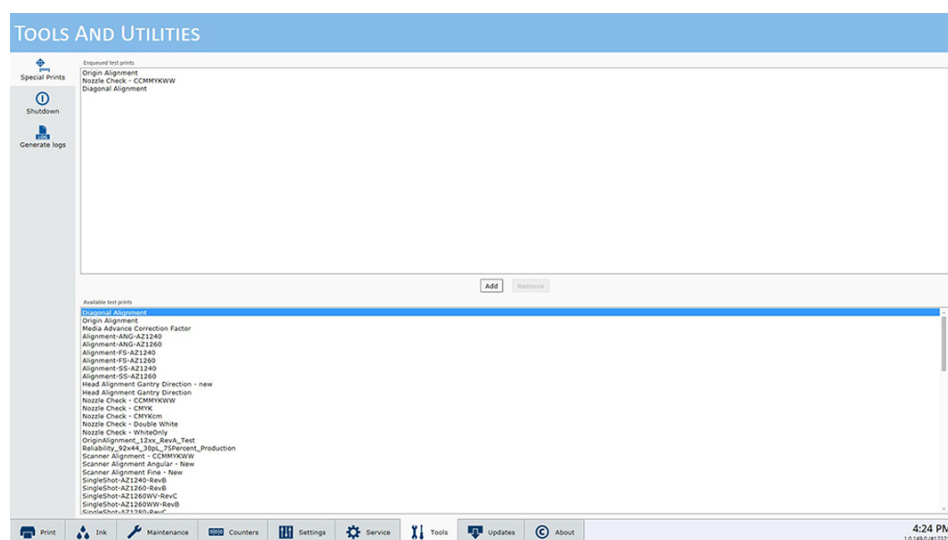

Special Prints

The Special Prints module displays two lists. The list on the bottom shows the available special prints. Some of these prints are used by service technicians to adjust and troubleshoot the printer. Some are of interest to the Operator: the Ship print, the table ruler prints, the Nozzle Check print, and the Media Advance Correction Factor print.

Special Prints of Interest to the Operator

- The **Ship print** is used to determine that the printer output meets quality standards. A ship print that is printed at the factory is shipped with each printer. It can be used as a comparison with one printed at the customer site.
- The **Table Rulers** are meant to be printed on the table to assist you to place media. These images are set up to print on the horizontal and vertical axes of the table. They are available in metric or imperial measure.
- The **Nozzle Check** is used to determine if there are any clogged nozzles that can affect print quality (note that it is also available on the command toolbar in the Print Job Control module).
- The **Media Advance Correction Factor** print (used for roll media only). This print is used to correct a certain type of banding related to incorrect media advance - see How to Determine Media Advance Correction.

The list on the top shows all active jobs that are currently in the print queue. Add a special print from the bottom to make it active in the Print Job Control module. If you remove a job from this list, it is also removed from the Active job list and is not available to print. Special print instances that are removed from the Active list do not go to the Inactive list; they are simply removed from the list.

Loading a Special Print

- 1) Click a special print to select it in the bottom window.
- 2) Click the Add button to place it in the print queue on top.

Printing a Special Print

Go to the Print Job Control module to actually print the special print. It will appear in the active job list and is printed like any other print job.



NOTE

Refer to the sections that document the special prints for details on printing. For example, the Nozzle check and the Ship print are printed on I/O paper, while the Ruler Guide Print is printed directly on the table. Note that some of the special prints are meant for service technicians only and are not for use by the printer operator.

Shutdown

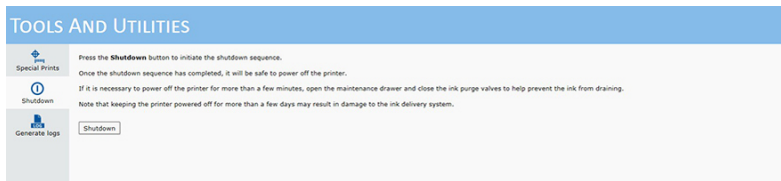

Use the Shutdown icon when you need to turn the printer power off. The printer should be left powered On at all times but there are some exceptions such as some service procedures, or if the printer requires a reboot.



IMPORTANT

Using the main power switch before performing a proper shutdown may damage the printer's internal hard disk.

Generate Logs

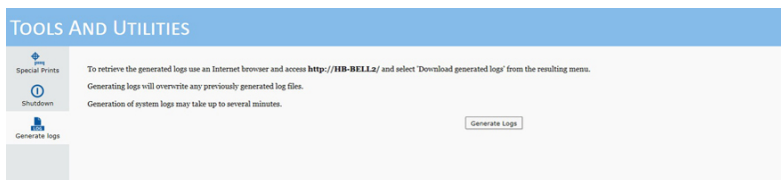

The System Logs are raw data log files for service diagnostics and troubleshooting purposes. They are meant for service technicians only. Generate system logs only when requested by an Océ service technician and follow the instructions they provide for retrieval of the files. When System Logs are generated, any previously saved log files are deleted. Therefore, do not generate a second batch if you have just recently generated log files (unless requested to do so by a service technician).

Software Update Module

Introduction

As we are committed to improve and refine the quality and functionality of the Océ Arizona 1200 Series printer, there will be periodic upgrades to the underlying firmware and printer software. Software updates are available only to customers with a service contract. Your local service representative will either install the upgrade or provide you with the upgrade file in some circumstances.

Illustration

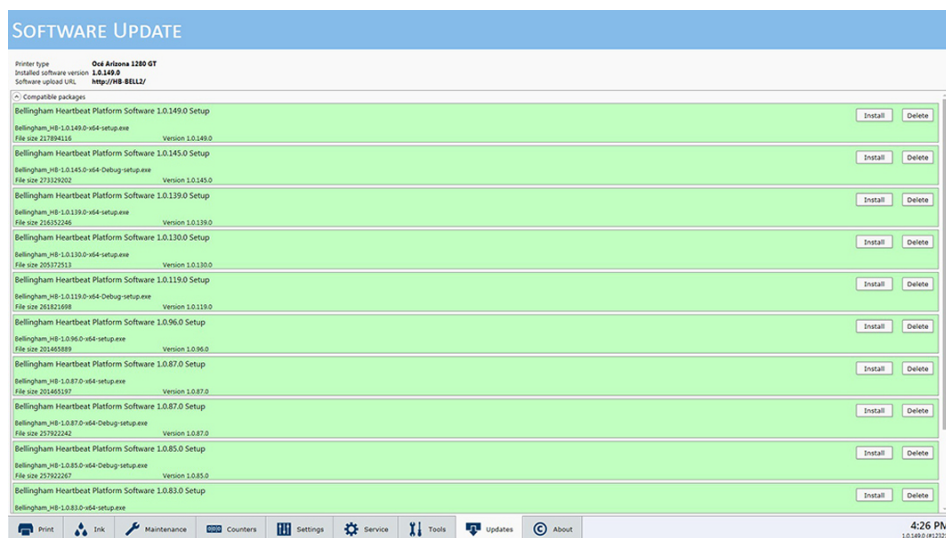

How to Upgrade the Firmware and Software

Your dealer or service representative will advise you when an update of the printer software is necessary. If they request that you install the upgrade, an unzip password will be provided and instructions are available from the DGS website when the update file is downloaded.

Chapter 5

How to Operate Your Océ Arizona Printer

Training Requirements

Introduction

The operator must receive training for safety issues, printer operation, and the appropriate ONYX Workflow software (ProductionHouse® or THRIVE) prior to operating the printer.

Safety Training

Before operating the Océ Arizona 1200 Series printer, make sure you have read and understood all of Chapter 3 "Safety Guidelines".

Océ Operator Training

For optimal safety and print quality, all printer operators must have received training by qualified Océ service personnel. Océ training provides a general orientation to printer safety and operating procedures. This User Manual is not a substitute for official training.

Onyx ProductionHouse Training

Maximum performance from the printer requires a properly trained operator. Océ trains the operator in the use of the printer hardware and software at installation. However, this is not a substitute for formal training.

Operators must be fully versed in the operation of ONYX Workflow software. For any operator unfamiliar with their operation, ONYX ProductionHouse® or THRIVE training is required. Training courses are available; contact your local representative for an ONYX-certified training program.

How to Power ON and Off

Introduction

It is critical for the printer to remain powered ON at all times. Power is required in periods of inactivity so the printer can perform automatic functions to maintain its operating state. If these functions do not take place, damage to critical components can occur. However, it may be necessary on occasion to cycle power on the printer or to recover from a power outage.

How to Power ON and Off

Procedure

1. Ensure that the AC power plug is properly seated.
2. Turn the AC power switch to the On position.



[22] AC Power Switch

3. Turn on the power of the Control Station LCD monitor, if necessary.



NOTE

During the boot-up procedure, the printer software is automatically started. The software displays a splash screen. The splash screen will show initialization messages and then the Print Job Control module screen appears. The initialization is complete when the top left panel of the display shows "Ready". Your printer is now ready for use.

How to Power Off

1. Turn OFF the UV lamps and wait for the lamps to cool down (the lamp fans will stop once the lamps have cooled down).
2. Click the Shutdown icon in the Tools and Utilities tab.
3. Turn the AC power switch to the OFF position



IMPORTANT

Do not leave the printer powered OFF for longer than 30 minutes. Power is required in periods of inactivity so the printer can perform automatic functions to maintain its operating state. If these functions do not take place, damage to critical components can occur. If the printer needs to be shut down for an extended period of time please contact your local service representative so that the ink can be properly flushed from the system.

How to Set Up a Print Job

Introduction

This section explains the basic steps to set up a print job.

Prepare a Digital Image with ProductionHouse or Postershop

Operator must be trained to use ProductionHouse or THRIVE. Training is provided by ONYX.

Print The Job From Onyx ProductionHouse

When the job is sent from the ONYX software, the job transmission progress is indicated in the lower right corner of the User Interface display. After the transmission has completed it will appear in the list of Active print jobs in the Job Control Module.

Perform Printhead Maintenance (if this is the first print of the day)

Refer to the Maintenance section in this manual for details. This must be done at the beginning of the work day or when image quality problems appear.

Measure Media Thickness

Use a digital slide caliper or micrometer to accurately measure the media thickness of the media. An error in measurement of media thickness will affect bi-directional alignment and can contribute to the amount of graininess in the printed image or cause a carriage/printhead crash with the media.

Set the Printer to Flatbed

Select the Flatbed button on the toolbar to prepare the printer. This is required only when the printer is initially started, or if it is reset due to an error condition.

Select Job To Be Printed, Check Print Parameters And Verify Media Thickness

Click on the job to be printed from the active job list to select it. After it is selected the parameters on the job information and parameters panel will be displayed and may be modified if desired. Refer to the section Graphical User Interface Display for details on what is displayed and how to modify the job information.

Select Print Icon, Print Mode, and Confirm Media Thickness

When you select the Print toolbar icon it will gray-out the icon and the hand icon to the left of the job to be printed will turn green.

The print job's icon should change to red/orange, and also the Confirm thickness buttons should appear in the command toolbar right beside Media thickness field.

Enter the measured media thickness value in indicated measurement units.

Select the 'Confirm thickness' button.

Prepare Media for Printing

Place And Register Media On The Printer Vacuum Table

Place the media on the table in the orientation that matches the job to be printed and register the media to the print origin. In the next section there are more details on how to perform the following actions.

Select Active Vacuum Zones

Select the required vacuum zones to hold the media to the table using the table vacuum. The three vacuum zone control handles control which of the three zones on the printer table will have vacuum applied when the table vacuum pump is turned on. The vacuum zones are opened or closed using a quarter turn handle. Refer to the next section for details on the dimensions and placement of the vacuum zones.

Turn On Table Vacuum

Click on the Vacuum button in the top right corner of the printer software display to activate the table vacuum. Also a vacuum foot pedal switch is provided to turn the table vacuum on and off.

Mask Active Vacuum Holes Not Covered With Media

To hold the media to the table it is important to completely cover active vacuum holes with a masking material. The masking material should not be thicker than the media to be printed on. If a full bleed image is to be printed, the masking material should be the same thickness as the media to be printed on to prevent overspray from accumulating on the print head nozzle plates.



NOTE

When the vacuum is switched off, wait a few seconds before you switch it on again.

Clean Media, If Required

If the media is dusty or dirty, clean it with an appropriate cleaner. If using a liquid like isopropyl alcohol, allow sufficient time to dry prior to imaging.

Start Print

The Print button is located at the corner of the table where media is loaded. Press the Print button to start the print job. If the job was selected, the media thickness confirmed and the vacuum is turned on, printing will start after the ink and lamps reach operating temperature.

Managing the Table Vacuum

The Table Vacuum System

Introduction

The printer uses vacuum to secure media to the printer table. The table is divided up into multiple vacuum zones. Manual valves are used to activate or shut down the vacuum zones. In order for the system to work effectively, all the vacuum table holes must be covered.

Manual Vacuum Valve for Zone Control



[23] Vacuum Zone Control Handles

Vacuum Zone Control Handles

The valve handles determine the state of the vacuum zones. When the handle is vertical, the zone is open and has vacuum. To close a zone, turn the control handle a quarter turn clockwise to the horizontal position.



[24] Closing a vacuum zone

Masking the Vacuum Table

If your media does not cover all of a vacuum zone you must mask the area around the media to eliminate vacuum loss. Use scrap media or material that is equal to or less than the thickness of the media to mask the table. You can tell when the vacuum table is fully sealed when the vacuum gauge reads 20 "Hg.

Vacuum Table Foot Pedal

The vacuum foot pedal toggles the table vacuum on or off. It helps the operator to secure the media on the vacuum table since it allows hands-free operation. The vacuum must be turned on prior to starting a print, and the vacuum cannot be turned off until a print is completed.

Vacuum Gauge

The vacuum gauge is located on the table.



NOTE

Use the vacuum gauge to determine if a zone is properly masked. When the active zone is properly masked the gauge will read at 20"Hg (68 kPa) or higher. Small leaks can reduce this number and therefore the efficiency of the vacuum. Porous media can also degrade the vacuum effect.

If the vacuum gauge for an active zone reads below 10"Hg (34 kPa) and you have ensured that the area is properly masked and taped off, you may have a leak in the vacuum system. Place a service call only if you determine that the zone is correctly masked and the gauge reads consistently low.

How to Maintain the Vacuum Overlay Sheet

If ink build-up occurs on the overlay sheet, remove the ink. If it is not removed, the print gap can be affected and this may affect the vacuum table's ability to secure the media properly. To remove ink we recommend that you use a paint scraper containing a straight edge razor blade. Refer to the Maintenance section for more detailed instructions.

Using Vacuum Zones - Metric Zones

Introduction

When the printer is shipped, the vacuum zones are configured to support either common metric or imperial media sizes. The purpose of the vacuum zones is to reduce the preprint setup time by reducing the need to mask the open area on the vacuum table when printing on the most common size media.

The Océ Arizona 1200 Series GT has five control valves that determine the zones that are active when the table vacuum pump is on. Zone 1 area is always active, and the five valves control zones 2 through 6.

Metric Vacuum Zones

The following shows the locations and media dimensions associated with the factory-set metric vacuum zones. The name of the zone indicates which vacuum handle controls that zone (except 1 as that zone is always on).

The metric configuration is designed such that zone 6 can be reconfigured by a service representative from the 2.5m x 1.25m area size to 4'x8'.

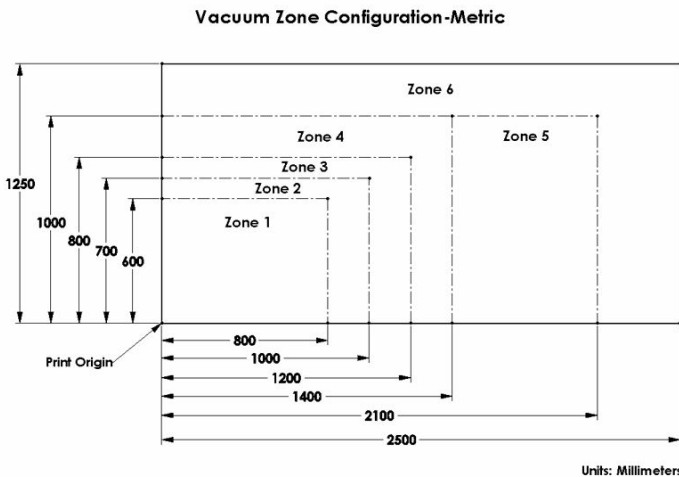

[25] Metric Vacuum Zones

Print the Metric Zone Map

A map of the vacuum zones can be printed on the table to help with the position of media over the zones. A default map is provided, but you can also create your own map, if desired.

Procedure

1. Select the Special Prints tab in the printer software.
2. Scroll to Vacuum Zones Metric - GT and add it to the print job list.

3. With no media present, print the zone map directly onto the printer table.

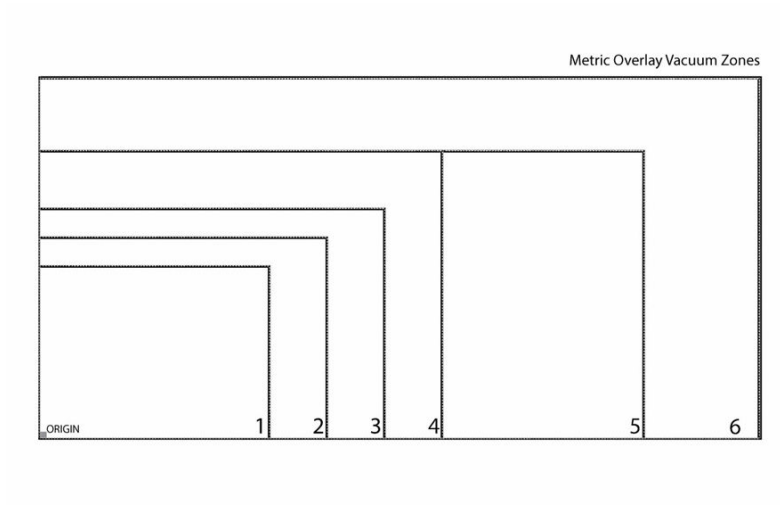

[26] Vacuum Zones Metric - GT

Imperial Vacuum Zones

The following shows the media dimensions that are available with the recommended Imperial vacuum zones. The name of the zone indicates which vacuum handle controls that zone.

The maximum supported media size for the imperial version of the vacuum table is 48 inches x 96 inches. However, the imperial design can provide an additional boundary at 49.2 x 98.4 inches, the maximum supported media size for the product. Shipped from the factory, the area between these two boundaries would be inactive. However, if necessary the maximum supported size could be increased by a service technician. This allows media to reach the 49.2 x 98.4 inches boundary.

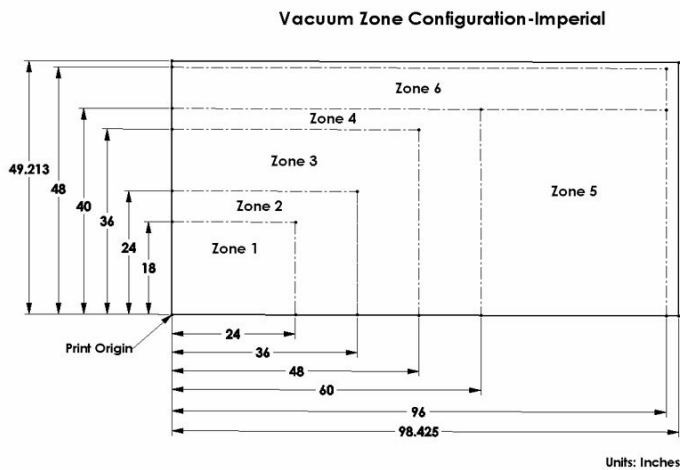

[27] Imperial Vacuum Zones

Print Imperial Zone Map

A map of the vacuum zone can be printed on the table to help with the position of media over the zones. A default map is provided, but you can also create your own map, if desired.

Procedure

1. Select the Special Prints tab in the printer software.
2. Scroll to Vacuum Zones Imperial - GT and add it to the print job list.
3. With no media present, print the zone map directly onto the printer table.

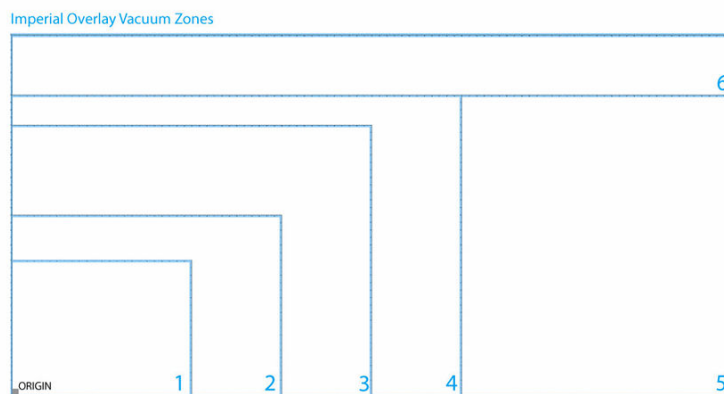

[28] Vacuum Zones Imperial - GT

Batch Mode Printing

Introduction

Batch mode printing is available for streamlining multi-layered jobs for specialty applications or facilitating set collation of multiple images on one piece of media. Individual print jobs are sent from the RIP to the printer, and then combined on the printer to create a batch job for flatbed printing. There are two types of batch mode jobs: Composite and Collated.

Composite

All images are printed on a single piece of media without interruption. Composite batch mode can be used if you want to print more than the three layers allowed in the ONYX software and/or mix print modes on the same piece of media. The first print job is printed, and then the carriage moves to the start position for the second print job and prints it. This continues until the last print job is printed and then the gantry moves to the home position to complete the batch job.

Collated

Collated batch mode prints a set of individual print jobs on separate pieces of media, and then repeats the number of copies of the set, as required. The carriage moves to the park position between each print job, the media is changed, the media thickness is confirmed and the **Start** button or **Start print** icon is pushed to continue printing the next image.

For example:

- If you want to collate 3 print jobs (J1,J2,J3) and print two 2 sets, the print order of the collated batch job would be J1,J2,J3,J1,J2,J3.
- If you want to print 3 copies of the same job double-sided with different images front (F) and back (B), the print order would be F,B,F,B,F,B.

Managing the Job and Batch Lists

Like in the Job lists, you can control the appearance of columns in the Batch job list: change the order that columns appear, the width of each column, and also select the columns to appear on the display.

1. Control the order of columns by dragging the column header to a different position.
2. Change the width of a column by clicking on the vertical line that separates column headers and dragging to the left or right.
3. Chose the columns to display by right-clicking on a column header and then click on a column name to add or remove it. Columns with a check mark will appear on the display and those with no check will not be seen.



NOTE

Columns can be set back to their original appearance by right-clicking any column header (name) and selecting **Reset to default**.

Procedure

1. Send the individual jobs to be batched together from the RIP to the printer (or use existing Active jobs).

2. Select the **Create Batch** icon to open the batch editor.

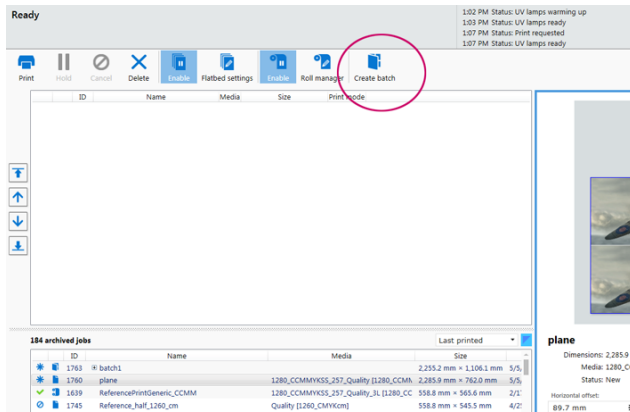

[29] Create a Batch Job

3. Provide a name for the batch job in the **Batch name:** field.
4. Select the **Batch type:** either Composite or Collation
5. Add jobs to the batch either by double-clicking or selecting a job and then clicking the **+ Add** button.
6. Use the mouse to place the selected images within the rectangle that represents the media in the Preview pane.



NOTE

Placement of images can be changed at any time by editing the batch job or by clicking the **+** to the left of the batch job name, selecting one of the included images, and then moving that image with the mouse.

Important: If you delete a batch job all of its component jobs are deleted and are no longer available unless sent from the RIP again.

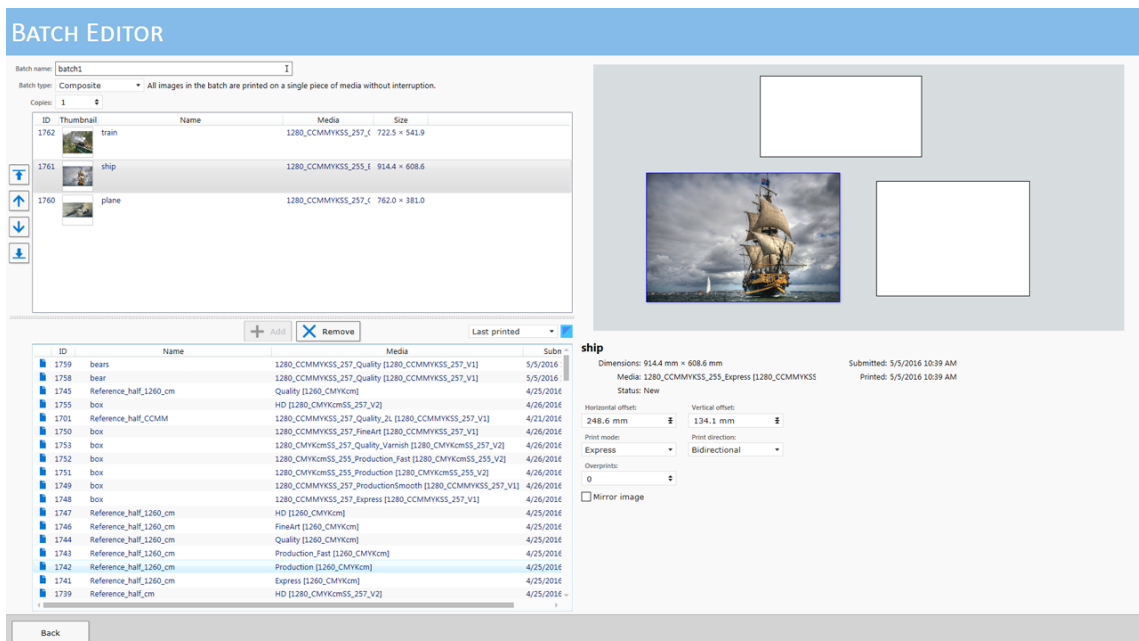

- When the images are arranged the way you want them, click on the **Back** button to return to the Print Job module and automatically add the Batch job to the Active job list.



NOTE

You can click on the + to the left of the name of a batch job in the Active Job list to see the images it contains. Select an image to move it by dragging with the mouse. You can also click the Edit Batch icon to open the editor to make changes to the layout and add or remove images.

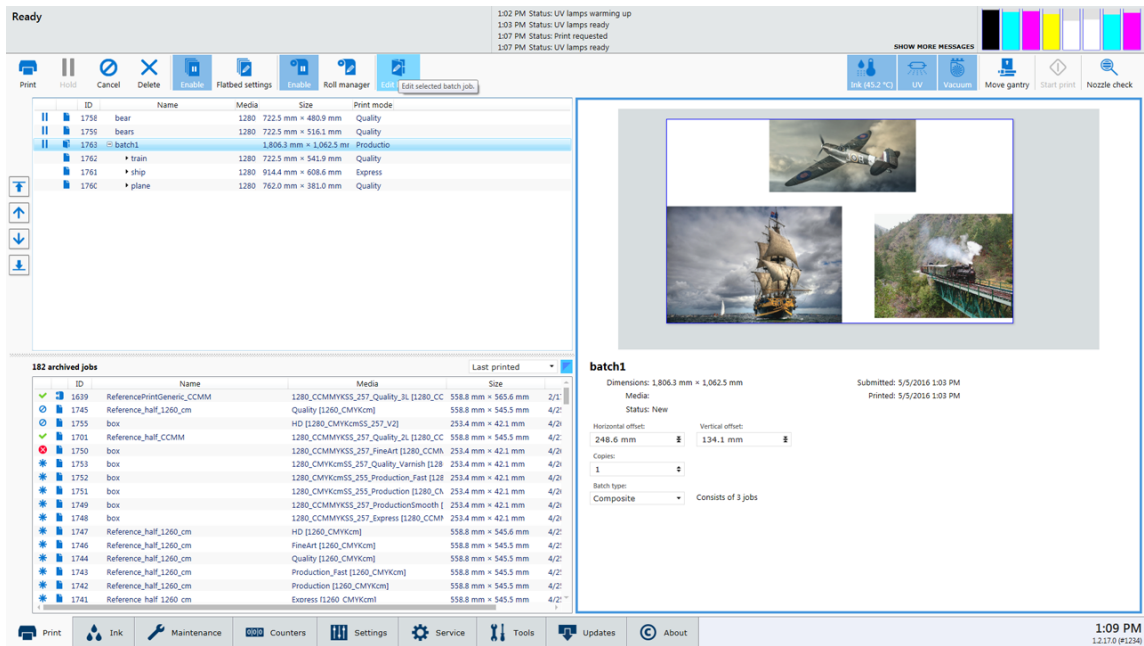

- Print the batch job by selecting it and then clicking the **Start print** icon.

Step and Repeat Printing

Introduction

Step and Repeat Printing allows the operator to define a grid and place an image in each cell to print multiple copies. The operator selects the number of rows and columns desired and the number of copies needed and the copies of the image are positioned in each cell of the grid. If there are not enough cells to hold the number of images the printer will wait for new media to be placed and then continue the job. The next part of the job will begin on the topmost row of the grid and print down until the set number of copies is achieved.

Step and Repeat printing is also possible on prints that are set up for the Roll Media Option. In this case the grid is also shown in the Preview and is centered on the paper if there is enough space on both sides of the grid. If there is not enough space for the size of grid and number of copies, the job will continue further along the media and will start again at the position of the left column. The job continues in this manner until the set number of copies has printed.

Step and Repeat Setup

The screenshot displays the printer's control panel interface. At the top, there are status indicators and a 'SHOW MORE MESSAGES' button. Below this is a toolbar with icons for Print, Hold, Cancel, Delete, Enable, Flatbed settings, Roll manager, and Create batch. The main area is divided into three sections:

- Job List:** A table listing 184 archived jobs with columns for ID, Name, Media, and Size. The selected job is 'plane' (ID 1760).
- Preview:** A visual representation of the print job, showing a 2x3 grid of airplane images.
- Configuration Pane:** A detailed setup area for the 'plane' job. It shows dimensions (2,285.9 mm x 762.0 mm), media type (1280_CCMYKSS_257_Quality), and a 'STEP AND REPEAT' configuration set to 2 rows and 3 columns. Other settings include 'Copies: 6', 'Print method: Flatbed', and 'Print direction: Bidirectional'.

At the bottom of the interface, there are icons for Ink, Maintenance, Counters, Settings, Service, Tools, Updates, and About, along with the current time (1:18 PM) and a printer ID (13170 #1234).

Procedure

1. Select a print job from either the Active or Inactive job list.
2. Select **Step and Repeat** in the Print Job Parameters pane.

- Fill in the **Rows** and **Columns** fields by either clicking on the upward pointing triangle or within the field to use the virtual keypad that appears.



NOTE

You can also click on the **Fill area...** button to have the grid created automatically based on the dimensions of the image, the size of the media, and the number of copies. If you use this method set the number of copies first.

Also, if you enter more columns and rows than it is possible to fit on the media, the fields will revert back to their previous number and turn red to alert you to this problem. Re-enter numbers that will allow the image to fit on the media.

- Click on the up/down triangles or in the field labeled **Copies** to set the number of copies required. You will see a visual representation of the grid in the Preview area and get from it an idea of how your requested copies fit on the media. If the number of copies exceeds the size of the media you will see how many media sheets are required displayed at the bottom of the Step and Repeat area.
- To set a gap (if required) between the prints in the grid click on the Vertical gap and Horizontal gap fields and use the Virtual keypad to enter the size of the gaps. The Preview will display the gaps.

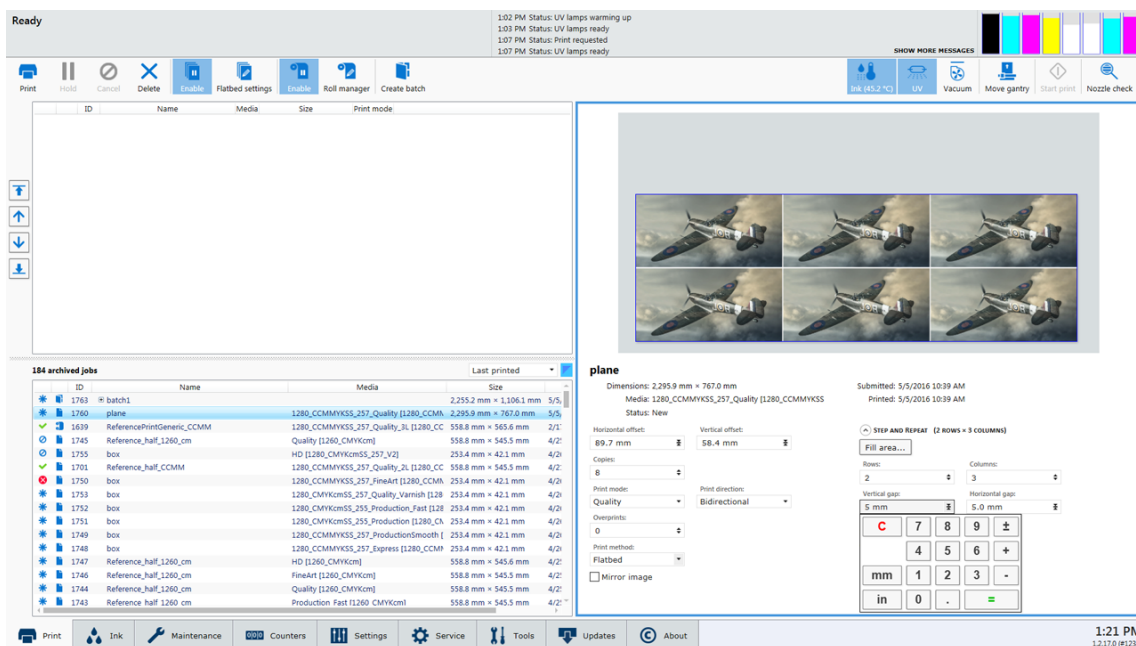

- When the Step and Repeat setup is complete, select the **Print** icon to add the job to the active list and then select **Start print** to send the job to the printer.



NOTE

If more than one piece of media is required for the job, the carriage will return to its parked position and wait for you to place a new piece of media, confirm media height, and select the **Start print** icon before it continues the job.

Managing Media

How to Handle Media

Introduction

Océ has conducted extensive testing of many media. Since your printer is capable of imaging on a wide range of material, we encourage you to explore various media so that you can establish your own criteria for achieving high quality images in your work environment.

Use ONYX media profiles to control ink density and to help achieve consistent color. If a media profile is not available for a particular media and it is not possible or convenient to create one specifically for that media, select a profile for another media that is similar in composition and color and the results will very likely be acceptable. Profiles are much less media-dependant for UV ink printers than for solvent-based printers. For access to ONYX profiles (media models), please consult our web site at: <https://dgs.oce.com>

Definition

The term media covers a wide range of possible materials for your printer. Essentially, any material that is less than 50.8mm (2.0 inches) thick, and less than the maximum size of 1.25m wide x 2.5m long (49.2 in x 98.4 in), can be considered viable media. Some materials will hold the ink better than others, so we encourage you to experiment with media to determine what works best for your purpose.

Note Attention Caution



IMPORTANT

When printing on reflective media, we advise that you monitor the nozzle check and printhead nozzle plates. Perform additional printhead maintenance, if required, to prevent ink from partially curing/gelling on the printhead nozzle plates.

How to Handle, Store, and Clean Media

See material-specific documentation for recommended handling and storage requirements. General material storage and handling suggestions follow:

- Store media in a dry environment avoiding high temperature, high humidity, or direct sunlight. The size of the material can change according to the temperature and/or humidity changes of the working environment. Ideally, store media in the same environmental conditions as it will be used.
- Store media flat to reduce tendency to bow. Do not use creased, damaged, torn, curled, or warped material.
- Do not leave material loaded in the printer for an extended period of time. The material may curl resulting in misalignment, jams, or decreased printing quality.
- Some material has a printable side and a non-printable side. If you print on a non-printable side, adhesion and color may be affected.
- Handle media with lint-free gloves. Oil deposits from fingers will degrade print quality. Do not touch the printable side of material.
- Media must be free of lint, dust, oil or other debris. Use techniques and solutions that are appropriate to the manufacturer's recommendations.
- Use a tack cloth to clean media as it will reduce static buildup. Press lightly when you use a tack cloth to prevent residue deposit on the media.



NOTE

Dirty media can affect image quality and reliability of printer output. If you wipe the media with a tack cloth before printing, it will reduce dust and debris buildup on the carriage underside. The tack cloth removes static and also removes dust and debris that tend to attract stray ink drops. Tack cloths are used by auto-body shops to clean cars before painting. Océ does not provide additional tack cloths beyond what is in the Accessory kit. If you did not receive a cloth or if you wish to purchase additional tack cloths, they are available at local hardware or auto supply stores.

Carriage Collision Recovery

If something on the table is higher than the media (or if the media is thicker than what is actually set in the print job settings), a carriage collision may occur. If a collision occurs, the carriage will stop and display a message on the User Interface panel. After the operator clears the offending media from the table and before the next print is started, printhead maintenance must be performed (See Printer Maintenance section).

How to Handle Media with Uncured Ink

If the UV ink is not properly cured, wear nitrile gloves when you handle prints. This will minimize the risk of skin irritation and sensitization from possible exposure to uncured ink.

Media Adhesion

Some media have better adhesion quality than others. Factors such as the amount of ink used and the amount of curing energy from the UV lamps can affect adhesion.

For more information on media adhesion, see Application Bulletin 6 on the customer support web site.

Media-Related Application Bulletins

For additional information on various aspects of handling and managing media refer to the Customer Support web site. See Appendix A of this document for a list of available bulletins or visit the web site to download bulletins:

<https://dgs.oce.com>

Thermal Expansion of Media

When imaging on media that will expand when subjected to heat (e.g., styrene or Plexiglas, etc), don't wedge the media by butting other material against it as this may cause the media to buckle. Also if multiple pieces of the media are used, allow enough space between the pieces to allow for thermal expansion. If you overprint on media that expands when heat is applied, we recommend that you group the desired image with the preceding image so the media stays at a consistent temperature.

Thermal Deformation of Media

Some heat-sensitive media may deform when subjected to high heat. If this occurs you can reduce the lamp power from the default setting of 7. You can also try to print uni-directional using only the trailing lamp (to do this set the power of the leading lamp to 0).

Media Registration

Introduction

Media can be registered on the table using the built-in registration pins and the table rulers. The registration pins can be linked to the vacuum switch or activated manually by the operator to allow quick registration of the media to the printer origin. The rulers are printed on the table and provide a horizontal and vertical rule that originate from the 0,0 print origin point on the table. The rulers can also help to provide offset distances if you need to start a print away from the origin point.

The registration pin system help the operator register media on the vacuum table. Registration pin operation can be set at the user interface to work in either manual or automated mode. Individual pins can also be set to Off or On in the menu.

In manual mode the vacuum foot pedal switch for the corresponding zone can be used to raise or lower the desired pins. This is done by keeping the switch depressed for approximately 2 seconds. For large format single sheet printing on an XT printer, depressing the zone A vacuum foot pedal switch for approximately 4 seconds will raise and lower the required pins to support large format printing.

In automated mode the registration pins will be in the **Up** position waiting for the operator to load media. Once the operator has registered media and initiated the table vacuum switch for the selected zone, the pins used to register the media for that zone will retract. After the print job is completed and the gantry has moved clear from the last print zone, the relevant pins will return to their **Up** position and the table vacuum will be turned off. To eliminate the possibility of a crash between the pins and the gantry or carriage, the printer verifies the **Down** state position of each pin when possible interference conditions may exist.

When the printer is powered on, but not ready to print, all registration pins will be in the **Down** position.



IMPORTANT

Do not slide heavy media into the pins with excessive force.

Media with abrasive edges can damage the pins - handle carefully.

Ink contamination can cause pins errors (see Pin Maintenance section below for cleaning tips).

Setting Registration Pin Behavior for GT Printers

You can set the behavior of the GT registration pins and also determine which of the pins are active in the Settings tab.

The media registration pins behaviors for a GT include:

- Off
- Independent of vacuum (manual)
- Linked to vacuum (automatic)

Determine which pins are active by checking or un-checking them on the grid.

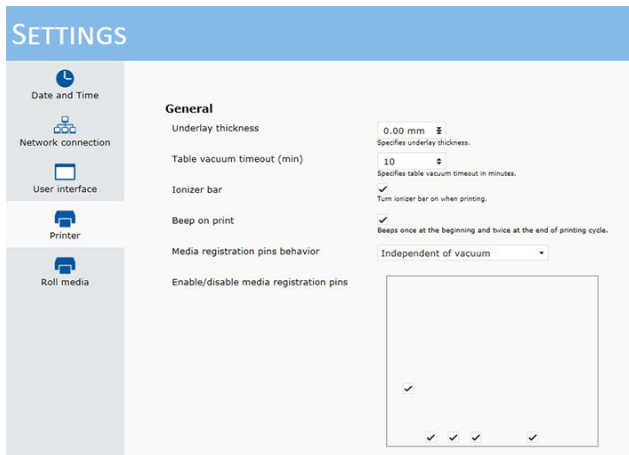

[30] Settings for a GT Printer

Setting Registration Pin Behavior for XT Printers

You can set the behavior of the XT registration pins and also determine which of the pins are active in the Settings tab.

The media registration pins behaviors for an XT include:

- Off
- Independent of vacuum (manual)
- Linked to vacuum, zone A only (both groups - vertical and horizontal);
- Linked to vacuum, zone B only (both groups - vertical and horizontal);
- Linked to vacuum, Full table mode (both groups in Zone A + vertical in Zone B);
- Linked to vacuum, zone A and B - 2 up mode (both groups in either Zone A or Zone B).

Determine which pins are active by checking or un-checking them on the grid.

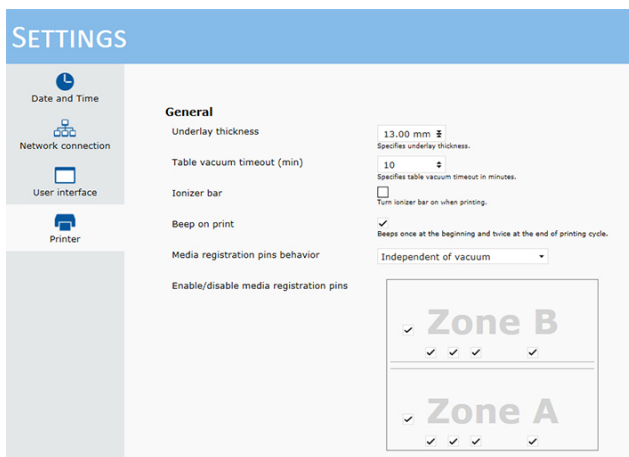

[31] Settings for an XT Printer

Registration Pin Error Handling

Three Levels of Safety:

1. Before any gantry motion begins, the printer software retracts all registration pins.
2. Each of 4 pin groups has a “safety zone”. When the moving gantry enters any of these zones, all pins from the appropriate group retract to provide safe gantry passage.

- If pin behavior is set to manual – the user is allowed to activate pins using the table vacuum pedals. However, if the gantry is within safety zone of any of the pin groups, that group will ignore request to extend. The same is true if pins are in one of automatic operational modes.

Error handling

In case any of the pins is stuck in either UP or DOWN position, gantry motion is stopped, printing cancelled and the "registration pin error" window will pop-up. Safety zones ensure detection of a pin that failed to retract and the gantry stops before it hits that pin.

The pop-up error window informs the user that the software detected undesired pin position, and it will show possible reasons for the error (air pressure, sensors) and ask user to visually check if all pins are in retracted (DOWN) position. There are two buttons in this error window - one allows the user to re-initialize pins and another button allows the user to completely disable the pins. Pins are automatically re-enabled on the next printer power-up, so they go through usual initialization process.



NOTE

If initialization fails, the same process of error handling repeats. In this case you must request a service call.

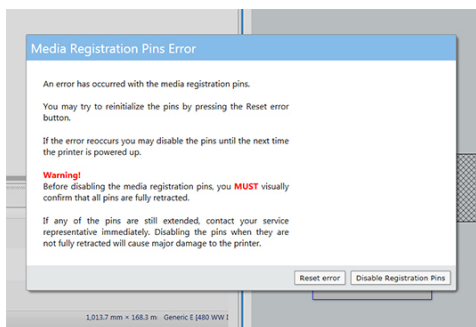

[32] Registration Pin Error Window

Registration Pin Maintenance

During a print job with a bleed, ink will deposit on the top surface of the pins and pin housings. The accumulation of ink on these surfaces should not grow beyond the top surface of the overlay. When this occurs remove the accumulated ink by using a razor blade or scraper on the top surface of the overlay only (with pins in the down position). It is also possible to clean the top surface of each pin with the same tools in their up position.



IMPORTANT

- Do not use any cleaning solutions to clean pins
- Do not lift overlays to clean pins
- Do not dig out ink from below the top surface of the overlay as this may damage the surface of the pin.

Chapter 6

Operating the Océ Arizona 1200 XT

Océ Arizona 1200 XT Features

Introduction

The Océ Arizona 1200 XT printer has a larger table and two vacuum pumps. These pumps provide vacuum for the vacuum zones. Any unique features of the Océ Arizona 1200 XT are documented in this chapter. All other features and specifications (other than print sizes) are the same as those for the Océ Arizona 1200 Series GT.

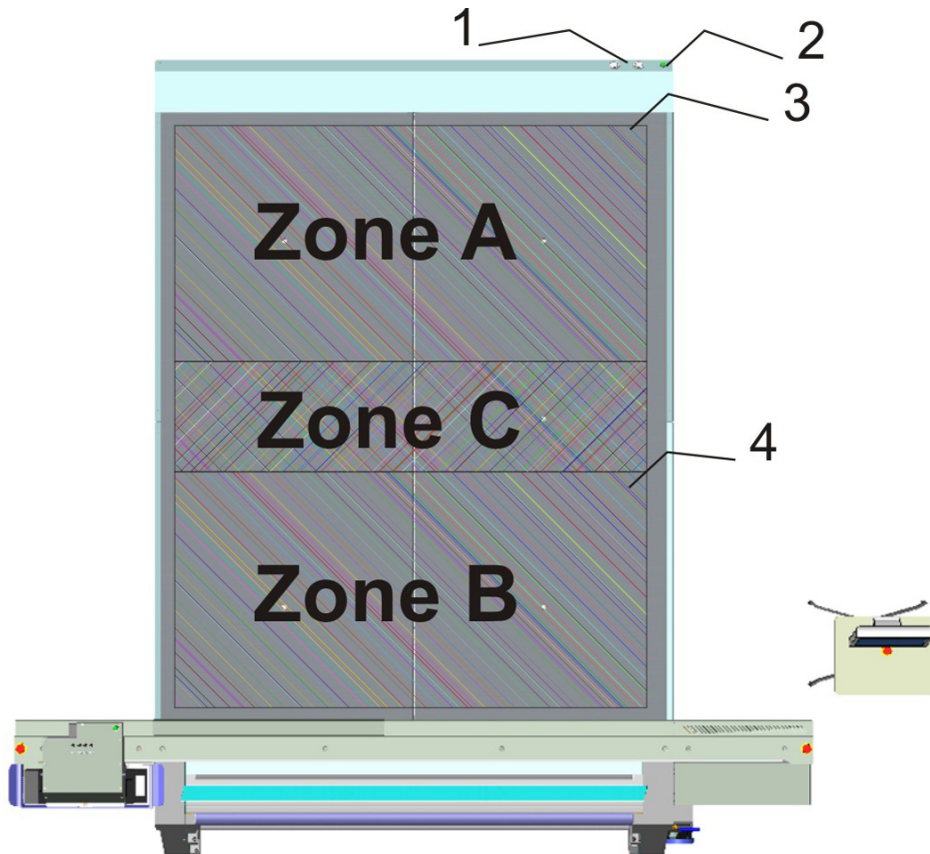

[33] XT Printer Hardware

Label	Hardware Description
1	Vacuum Gauges for A and B Zones
2	Print Start Button
3	Print Origin for A Zones
4	Print Origin for B Zones

Media Support

The Océ Arizona 1200 XT printer supports media up to 2.50m x 3.08m (8.2 x 10.1 feet) in size with a 5mm (0.2") bleed on all edges. It can also print on alternating 2-up media that is 1.25m x 2.5m (4'x8') in size.

How to Use the Océ Arizona 1200 XT Vacuum System

Introduction

The Océ Arizona 1200 XT uses vacuum to secure media to the printer table. Two independent vacuum pumps provide vacuum to the table, which is divided into multiple vacuum zones. Pump 1 provides vacuum to the A Zones and the C Zone. The operator can control vacuum flow to the C Zone with the manual On/Off valve. Pump 2 provides vacuum to the B Zones. All XT printers are shipped with metric vacuum zones. It is possible to change the configuration from metric to imperial in the field by a qualified service technician (the technician who installs your printer can do this, if needed).

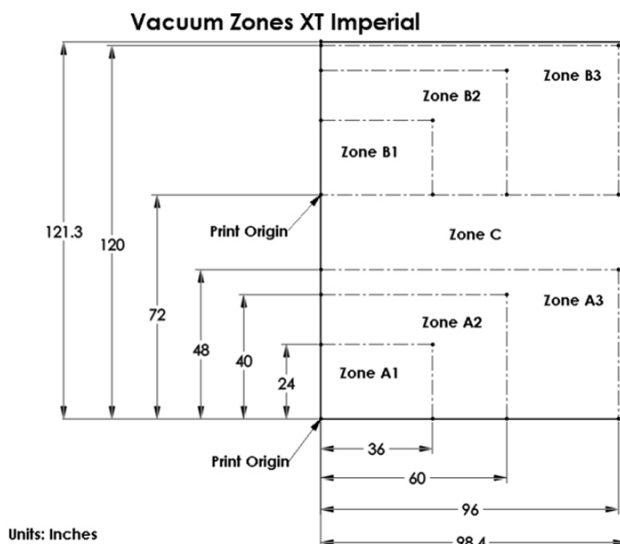
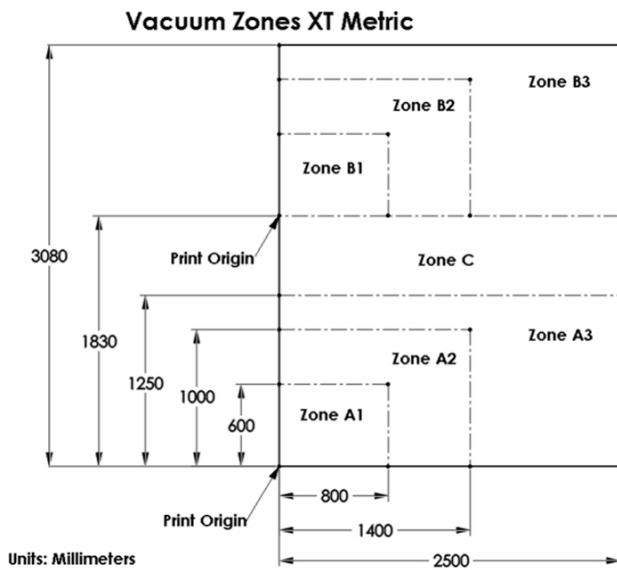

There are three A zones and three B zones as indicated in the illustrations. These zones are controlled by five vacuum handles. Zones B1 and A1 are always on when the vacuum is activated. Zones A2, A3 and B2, B3 are controlled by the position of the two left and two right vacuum handles. The C zone is controlled by the middle vacuum handle.

The independent control of the zones allows the operator to print in a Dual Origin mode with minimal down time.



NOTE

Use the vacuum gauge to determine if a zone is properly masked. When the active zone is properly masked the gauge will read at 20"Hg (68 kPa) or higher. Small leaks can reduce this number and therefore the efficiency of the vacuum. Porous media can also degrade the vacuum effect.

If the vacuum gauge for an active zone reads below 10"Hg (34 kPa) and you have ensured that the area is properly masked and taped off, you may have a leak in the vacuum system. Place a service call only if you determine that the zone is correctly masked and the gauge reads consistently low.

Procedure

1. Place media on the table at the desired location (use the table rulers or the registration pins to help with placement - see Media Registration).



NOTE

To place media at the print Origin B (Origin A is the default) you need to set that up either in the ONYX software or after the job is sent in the Print Job screen (this is explained in the next section "How to Print with Dual Origin").

2. Mask off any areas of the active vacuum zone(s) that will not be occupied by the media.
3. Activate the zones you wish to use either with the icon on the command bar of the Print Job module or with the matched foot switch (A or B) on the floor.
4. Start the print job either with the Start icon on the command bar or with the Print Start button located near the vacuum gauges.
5. De-activate the zones with either the icon or the foot switch once the image is printed.
6. Remove the media.

How to Print With Dual Origins

Introduction

Due to the larger table size and the vacuum zone arrangement of the Océ Arizona 1200 XT printer, it is possible to print in an alternating 2-up arrangement using Origin A and Origin B for placement of the image.

Purpose

Dual Origin is used to print more than one copy of a specific print job on media not larger than 1.25 x 2.5 meters (4 x 8 feet). This allows greater productivity when printing multiple panels.

If the dimensions of your image are not greater than 1.25 x 2.5 meters (4 x 8 feet), the Dual Origin option is available from the Job parameters menu.

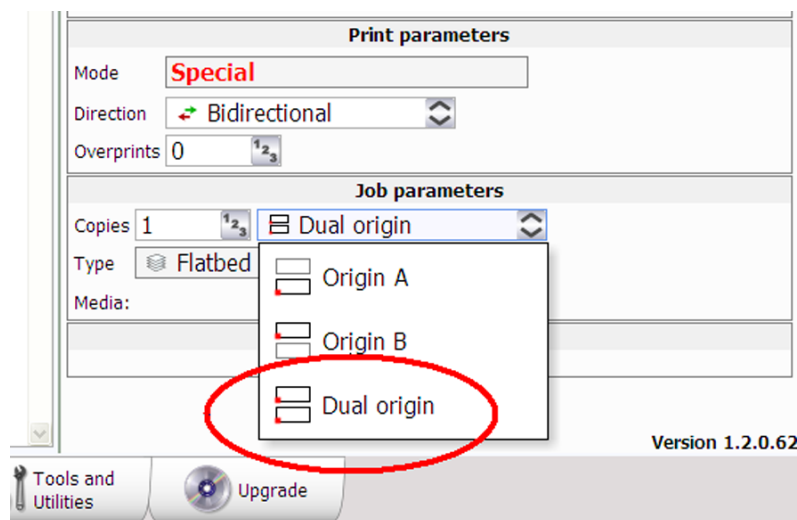

NOTE

It is also possible to select Dual Origin in the ONYX workflow application. In Layout preview, the Preferred Origin field can be selected from a pull-down menu with the choices Origin A, Origin B, or Dual Origin Mode. If you don't select Dual Origin it can still be made active after the job is sent to the print job queue, as explained below.

Procedure

1. Add your image to the active print job queue and then select it.
2. Enter 2 or more copies in the Job Parameters Copies field.
3. Click on the Origin pull-down menu and select Dual Origin to make it active.



NOTE

When Dual Origin is selected, a scaled view of the image appears on the screen preview in Zone A and a bounding box that represents the image appears in Zone B. Both images are displayed at their respective origin points. If you move the primary image in Zone A to a new origin (enter new offsets), both images will then print from that changed relative origin point. The red cross-hatched area is a reminder that it is not possible to print in the Center zone when dual origin is selected.

4. Place media in Zone A, mask off any unused areas, and then turn On the vacuum.
5. Press the Start button to begin the print in Zone A.

- Place media in Zone B, mask off any unused areas, and turn On the vacuum. After the print in Zone A is completed the gantry will move to Zone B and start printing.



NOTE

The printer will not print in Zone B if the vacuum is not On. It will display "Waiting for Table Vacuum" and wait in the Center Zone until the vacuum is On and then will also require that you press the Start button.

- If additional copies of the print were indicated in Step 2, then repeat Steps 5 to 7 (in alternate zones) for the total number of prints required.

Result

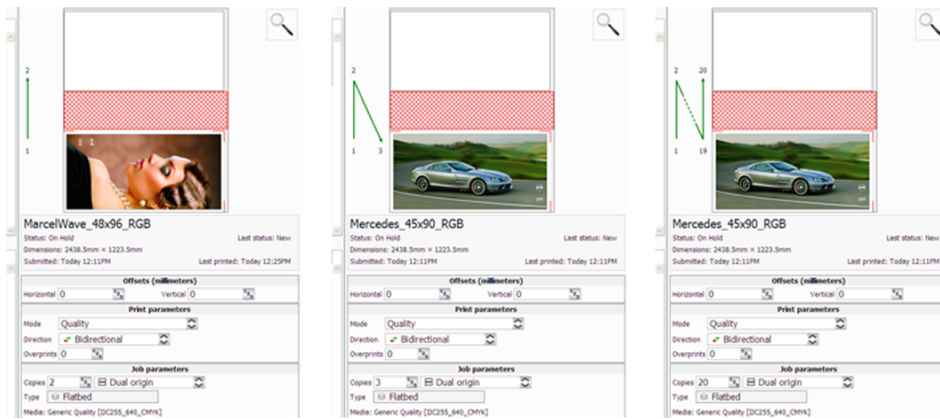

NOTE

The green arrows show the order in which images are printed in Zones A & B when Dual Origin was selected.

Chapter 7

Roll Media Option

Hardware

Introduction

The Roll Media Option (RMO) allows printing on media that is supplied on a roll.

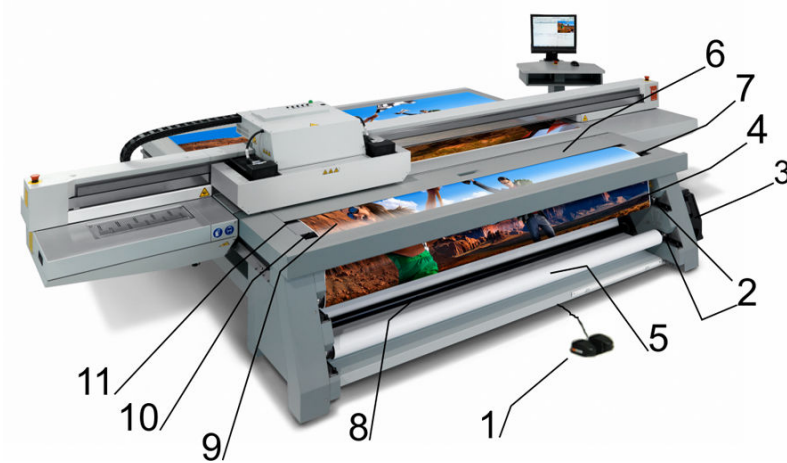

[34] Roll Media Option Components

Component Locations

Roll Media Hardware

Component	Function
1) Dual Foot Pedal Switches	6) Media Access Door
2) Media Drive Couplers	7) Media Cut Guide
3) Accessory Holder	8) Media Tension Bar
4) Take-up Media Shaft	9) Vacuum Platen
5) Supply Media Shaft	10) Gimbal
	11) Capstan

Hardware Function table

The Roll Media Option consists of a supply media drive, media tension bar, capstan roller, vacuum platen, media gimbal, and a take-up media drive. This system accurately advances the roll of media during printing. The roll media is positioned with a high resolution media encoder. This ensures accurate and high quality printing.

Roll Media Hardware

Component	Function
1) Dual Foot Pedal Switches	Controls media feed in both forward and reverse directions. Function varies depending on whether media is loaded or unloaded.
2) Media Drive Couplers	Keeps the media shafts in place and engaged to the drive motor. In the open (horizontal) position they allow the media shafts to be removed.
3) Accessory Holder	Stores tape, cutting blade and 5mm hex key tool.

Component	Function
4) Take-up Media Shaft	Supports the take-up media roll.
5) Supply Media Shaft	Supports the supply media roll.
6) Media Access Door	Provides access to the supply media for media loading.
7) Media Cut Guide	Allows easy cutting of the media.
8) Media Tension Bar	Provides tension to ensure steady movement of the media.
9) Vacuum Platen	Holds the roll media in place while an image is printed.
10) Gimbal	Maintains alignment of the media on the take-up shaft.
11) Capstan	Determines the location of the media for printing and provides steady movement of the media.  NOTE The capstan must always be clean and smooth. Clean any kind of debris that might collect on it, especially UV inks (See RMO Maintenance section for cleaning instructions).

Specifications

Introduction

Specifications associated with the use of roll media are indicated in this section.



NOTE

The Roll Media Option must be operated in accordance with the environmental conditions specified in the Océ Arizona 1200 Series Site Preparation Guide and all safety requirements noted in this document.

Media Size Supported

Width (Max.): 2.2m (86.6")

Width (Min.): 0.9m (36")

Roll Diameter (Max.): 240mm (9.45")

Core Inner Diameter: 76.2mm (3")

Weight: up to 50kg (110lbs)

Print Size Supported

2.190m (86.2")

This allows for a minimum 5mm (0.2") border. This is necessary to ensure the platen is not contaminated with ink due to possible media tracking errors. Cured and uncured ink on the platen will have a serious effect on printer performance. Any spilled ink must be removed immediately (See RMO Maintenance section). If an image exceeds the 5mm border requirement, printing will not be allowed to proceed.

Maximum Media Thickness

This value is not officially specified. It is theoretically possible for the RMO system to accommodate media up to 3mm (0.11 inches). However, most media at or near that thickness will have problems in the transport mechanism of the RMO unit.

Leader & End of Roll Waste

Leader Waste: 560mm (22 inches)

Leader waste is the amount of media that cannot be printed between the roll media platen and the take-up media roll. This waste is produced every time media is loaded, taped to the take-up core and initialized in preparation for the first print.

End of Roll Waste (minimum possible): 920mm (36 inches)

End of roll waste is the media that cannot be printed at the end of the supply media roll. This will vary slightly depending on the attachment method that was used to secure the media to the media core.

Foot Pedal Switch Functions

Introduction

The foot pedal switches are used to control the forward and reverse movement of media shafts.

Summary of Dual Foot Pedal Switch Functions

The following table indicates the foot pedal functions for various RMO states.

Actions for foot pedals in various states

RMO State	Media Reverse		Media Forward	
	Left Hold	Left Tap	Right Hold	Right Tap
Load Media	Rewinds media onto supply shaft	Unlocks media supply shaft	Advance media from supply shaft	Unlocks take-up shaft
Initialized	Rewinds media	n/a	Advances media	n/a
Unload (before media cut)	Important: Don't touch the pedal switches Media is positioned for cut when you click on the Unload icon Cut the media, then proceed with unload			
Unload (after media cut)	Unwinds media from the take-up roll	Rewinds media and unlocks the supply shaft	Winds media back onto the take-up shaft	Winds media and unlocks the take-up shaft

Roll Media Manager

Introduction

The Roll Media Manager is the area of the printer software where you prepare to print on roll media. With this menu you can load and unload media, change media type and parameters, and initialize the printer to prepare it to print on roll media.

How to Access the Roll Media Manager

Click on the Roll Manager icon in the command toolbar of the Print Job module.

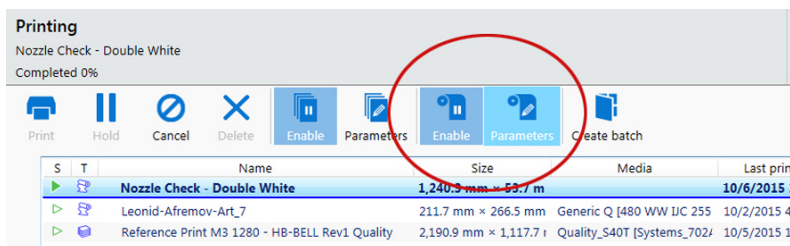

The Roll media manager is displayed.

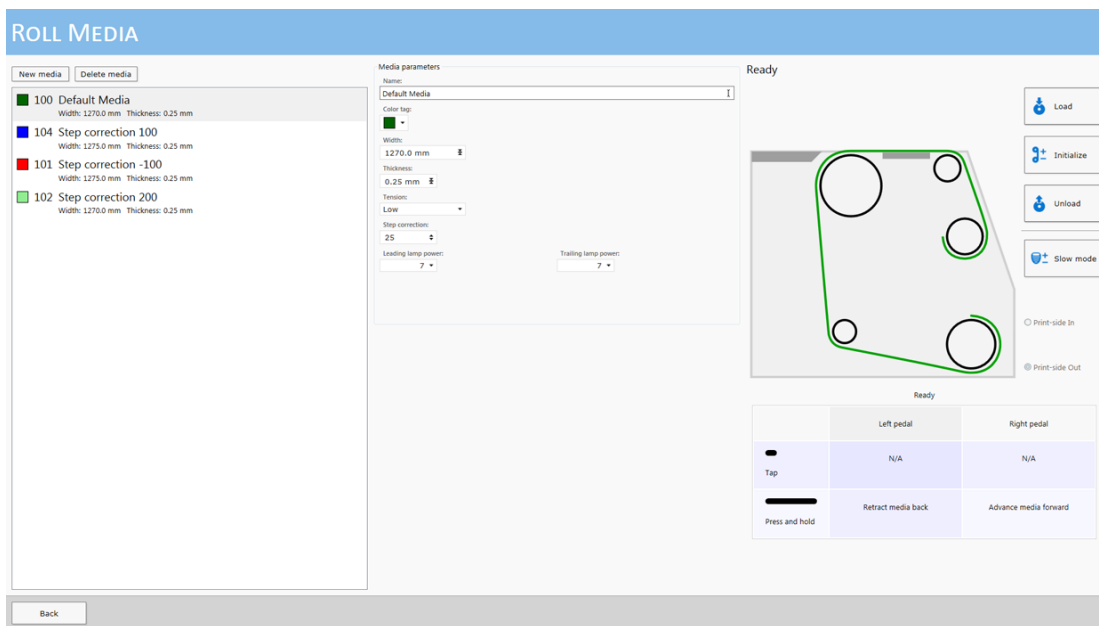

Roll Media Manager Menu

Roll Media Manager Functions

Icon	Function
Load	Allows the operator to load new media. Set the foot pedal switches to the Load state.
Unload	Prepares the RMO to allow the operator to cut the existing media, remove it, and replace it with a new roll.

Icon	Function
Initialize	Sets up tension on the loaded media and prepares the RMO to print on that media.
Print Side	Operator can select either Print Side In or Print Side Out. Print Side In allows you to print on the back side of the media. The default setting is Print Side Out.
Media Parameters	Each roll media has a width and thickness that must be entered and you can also set the Tension and any step corrections required. You can create a new media or edit an existing one by changing the parameter values and then saving them under a new media name.

How to Use the Roll Media Manager

The procedures to use these icons to load and unload media is explained in the next two sections. How to verify or change media parameters and to actually print a roll media job is explained in the section "How to Print on Roll Media".

Loading Media

Introduction

This section details the following actions that are associated with loading media:

- A) Load Supply Media Roll On Media Shaft
- B) Load Take-up Empty Core On Media Shaft
- C) Loading the Media - Standard Method
- D) Loading the Media - Alternate Method

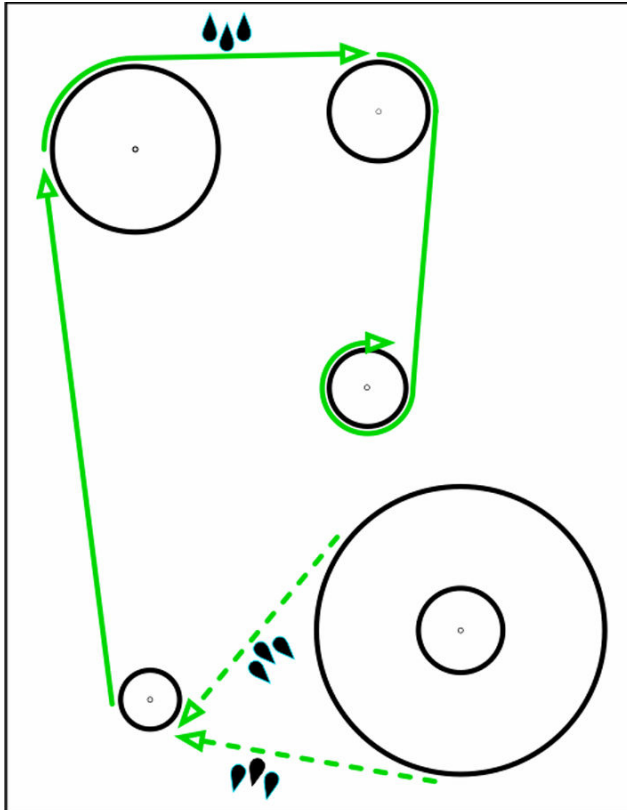

[35] Media Feed Direction

Media Feed Direction

Determine first whether you need the media roll to be print side out or in. "Print side out" means that the media unrolls from the bottom of the supply shaft. "Print side in", means that the media unrolls from the top of the shaft (see the diagram below). This allows you to print on the "back" side of the media.

Before you begin

It is very important that the media is wound properly onto the core when it arrives from the manufacturer. The media must be wound straight, tight and even from one end to the other. If you have a roll that is not even, before loading it, hold the roll in a vertical position and carefully and evenly drop one end onto the floor, then tap lightly a few times. If any edges are crushed, unwind and throw away the crushed area or cut off the crushed end of roll. If is not possible to repair, do not use it.

**NOTE**

If media has been stored on its side and has a pronounced flat side, do not use it as it will not advance evenly.

Required tools

5mm hex key

Load Supply Media Roll and Position a Take-up Shaft**Procedure**

1. Place an empty media shaft on a suitable flat work area, positioned as shown, so that the 5mm hex key is inserted on the right side of the shaft to lock and unlock the core locks.

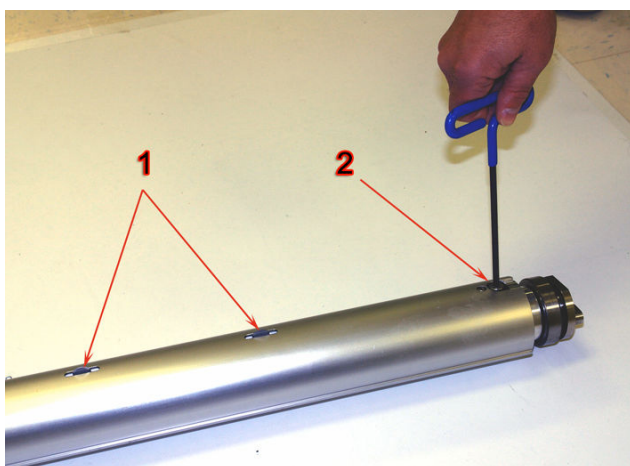

[36] Unlock the Media Shaft Core Locks

2. To unlock the media shaft core locks (1) turn counter-clockwise with the supplied 5mm hex key (2).
3. Slide a new roll of media onto the supply shaft.
4. Roughly center the roll on the shaft, and then insert the shaft into the Supply (bottom) position on the printer. Insert one end of the shaft at a time.

**NOTE**

Load the shaft with the core lock and coupler end on the right side of the printer.

5. Accurately center the media using the supplied ruler. Media should be centered within 1mm on the ruler.

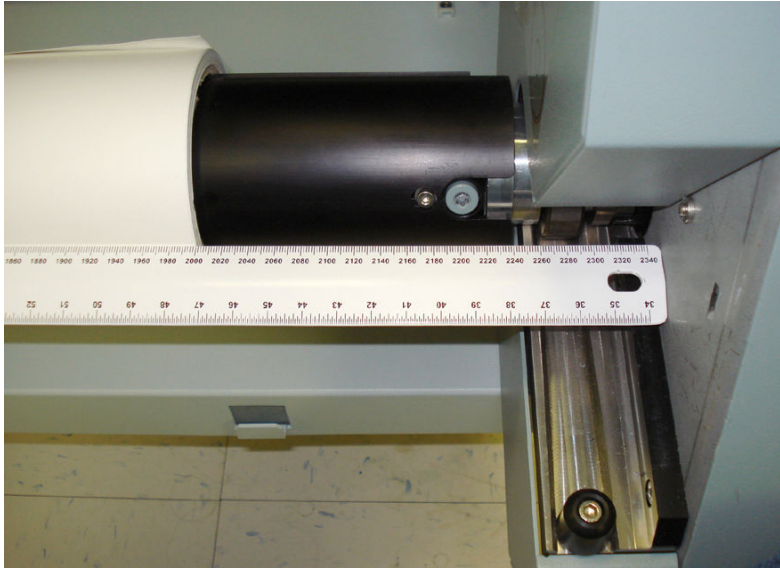

[37] Ruler to Center Media



NOTE

The supplied ruler has both metric (millimeters) and imperial (inches) scales. When a media roll is centered on the shaft, and the ruler is placed as shown in the photo, the value on the ruler scale will match the width of the roll. For example, in the photo a 2 meter (or 2000mm) roll is centered on the media shaft.

6. Lock the supply media shaft core locks by turning the 5mm hex key clock-wise.
7. Re-check that the media is still centered as locking the core may cause the roll to shift (usually the shift is from 1 to 2 millimeters to the right).

Next: Load an Empty Core and Install it in the Take-up Position

8. Place an empty media shaft on a suitable work surface and unlock the media shaft locks with the 5mm hex key.
9. Slide an empty media core that is at least as long as the supply media width onto the take-up shaft.
10. Roughly center the core and then insert the shaft into the Take-up (top) position on the RMO unit.



NOTE

Make sure that the core lock and coupler end of the shaft are on the right side of the printer.

11. Lock the take-up media shaft core locks with the 5mm hex key.

Result

The RMO is now ready to print on the roll media.

Loading the Media - Standard Method

The standard way to load media is quick and efficient and ensures minimum waste of material. However, for some longer print jobs or when you use media that is more flexible and therefore harder to achieve good alignment, there is an alternate method that will be described in Section D. Straight loading of roll media is very important to avoid wrinkles and banding in the print,

especially on longer print job runs. If you want to ensure that a media is loaded straight or if you see an inverted light/dark banding across the media, we recommend the alternative method.

Procedure

1. Select the Load icon from the Roll Media Manager.
2. If you are going to print with "Print Side In", click the icon in the Roll Media manager ("Print Side Out" is the default so you do not need to select it unless you have previously used Print Side In). Note that the icon toggles from one choice to the other when you click it.



NOTE

For Print Side Out, the media unrolls from the bottom the supply shaft.
For Print Side In, the media unrolls from the top of the supply shaft.

3. Wait for the gantry to move part way across the table.
4. Thread the media under the media tension bar (Note that the media is threaded for Print Side Out in the photo below). Pay out media with the foot pedal as required.

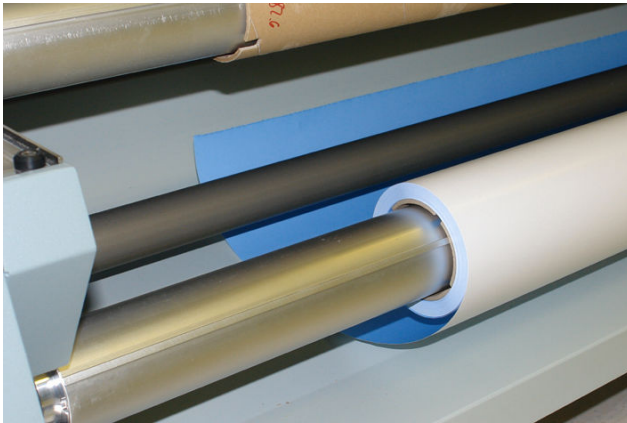

[38] Thread Media Under Tension Bar (Print side out)

5. Open the media access door at the top of the Roll Media unit, then reach down through the open door to grasp the media and feed it up and over until it reaches the take-up roll.



[39] Feed Media Through Access Door

6. Check alignment of the media by feeding it down to the supply roll and make sure that the edge lines up with the edge of the supply roll.



[40] Align Media

7. Rewind the media by continually pressing down the left foot pedal until it is positioned where it can be taped to the take-up core.
8. Tape the media onto the core. The media should have a clean straight edge prior to taping. First tape the center of the media to the core, and then tape both ends of the media.

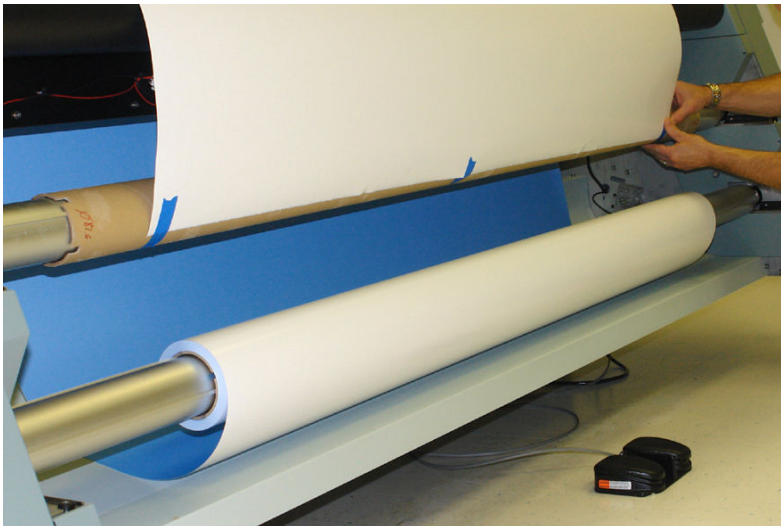

[41] Tape Media to the Take-up Roll Core



NOTE

Important: Use the supplied ruler to check that the edge of the take-up roll is aligned within 1mm of the feed roll.

9. Select the "Initialize" icon from the Roll Media Manager to prepare the RMO for printing.

Loading the Media - Alternate Method

This alternate method to load media requires a little more time and effort but it usually provides better alignment and therefore less chance of banding in the image. When roll media is not properly aligned, the result is overstepping on one side and under-stepping on the other side of the media so that the band in the printed image is dark on one side and light on the other. The alternate method is recommended for long print jobs where skewing of the media can become progressively more pronounced or when using media that has some flexibility and therefore proper alignment is hard to achieve with the standard method.

Procedure

1. Load the roll on the media shaft and begin the load procedure as described in steps 1 to 5 in the standard method, to the point where you have advanced the media over the platen until it lies over the bottom media feed roll.
2. Align the edges of the hanging media to the supply roll edges.
3. Once you have aligned the media edges to the supply roll, without moving the media any further, tape the media to the platen.

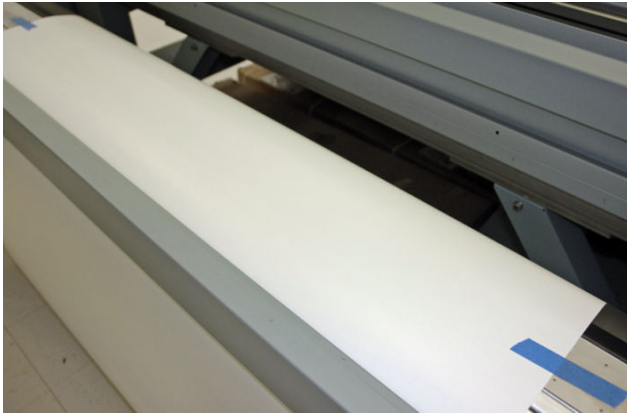

[42] Tape the media edges to the platen

4. Pull the hanging media edge taut and cut the media off from each edge at an angle to result in a point just below the take-up core as shown here.



[43] Cut the media at an angle

5. Tape the pointed end of the media to the take-up core as shown below.

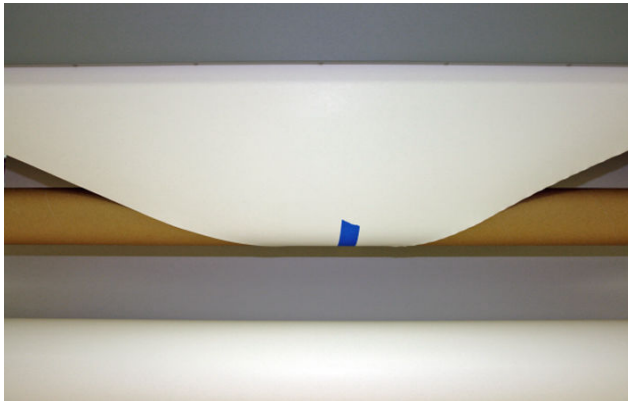

[44] Tape media to core

6. Remove the tape you used to hold the media to the platen.
7. Select the "Initialize" icon from the Roll Media Manager to prepare the RMO for printing.
8. After initialization has completed, advance the media until the cut area is wound onto the core across the width of the roll and verify with the ruler that the supply and take-up edges are at the same location.



NOTE

Important: Use the supplied ruler to check that the edge of the take-up roll is aligned within 1mm of the feed roll.

9. Start an RMO print job and verify image quality and that there are no wrinkles or banding.

Unloading and Removing Media

Introduction

This section explains all of the actions associated with how to cut and unload media when there is still some media left on the supply roll.

Unload Media Summary

The following actions are associated with unloading media:

- A) Initiate Unloading
- B) Cut the Media
- C) Remove Media from Take-up Shaft in Printer or Remove Take-up Shaft
- D) Remove Supply Shaft From Printer
- E) Remove Media Roll Or Empty Core From Media Shaft

Before you begin



NOTE

When you select the Unload icon the media will advance automatically by a preset amount. This distance is determined by the Move Media on Unload value in the Settings Roll Module tab. The default value will advance the media to a position past the Media Cut Guide so that the printed image is not cut. To manually increase this distance you can use the foot pedal to advance the media, but only before the Unload is selected. Once Unload is selected the foot pedals will not work until you Initiate a new RMO print job.

Required tools

5mm hex key

Procedure

1. Click on the Roll Manager icon to bring up the Roll Media Manager.
2. Select the Unload icon in the Roll Media Manager to release the tension.
3. Cut the media using the cutter guide.
4. Click on OK to proceed.
5. If you want to remove the printed images without removing the take-up roll from the printer you can press the left pedal to rotate the take-up media shaft in the reverse direction. You can then roll up the media by hand as it comes off the take-up roll.
6. To remove the take-up roll without manually rolling up the media, tap the right pedal momentarily to rotate the take-up shaft one revolution to the unlocked position in the forward direction.
7. If you want to change the supply shaft, momentarily press the left pedal to rotate the shaft to the unlocked position.
8. Remove the supply shaft from the printer by pulling it towards you. Pull one end out at a time.
9. Place the media shaft on a suitable work surface.
10. Unlock the media shaft core locks using a 5 mm hex key.
11. Slide the media core off the shaft.

Result

The media is removed and you can now add a different media to the shaft.

Setting Up a Roll Media Job

Introduction

Print jobs can be specified as either a roll job or a flatbed job in the ONYX workflow software. The job type can be changed after the print job is transferred to the printer.

Purpose

The operator can choose the type of desired print job and also put a hold on it so it will not print automatically.

Set up the Roll Job Option

When you set the page size for your print job, click on Type: Roll to make it a roll media option job.

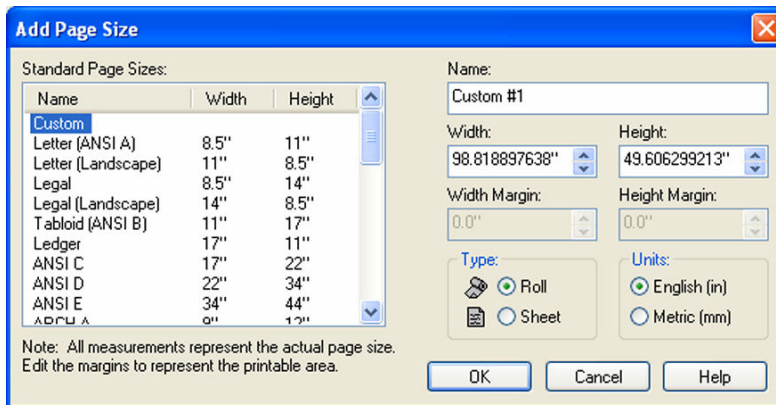

[45] ONYX Page Size - Roll Option

Set a Hold on a Roll Job

Procedure

1. To ensure that your roll media print job is held and not automatically printed, click on the box in front of "Hold for printer operator" when you set the print options while creating an RMO media in the ONYX workflow software



NOTE

If you don't set a hold, it is also possible to disable the Roll media print queue at the printer. To do this click on the Roll icon in the command toolbar of the Print Job module so that it become dim (grayed out). This will stop any roll media jobs from automatically printing.

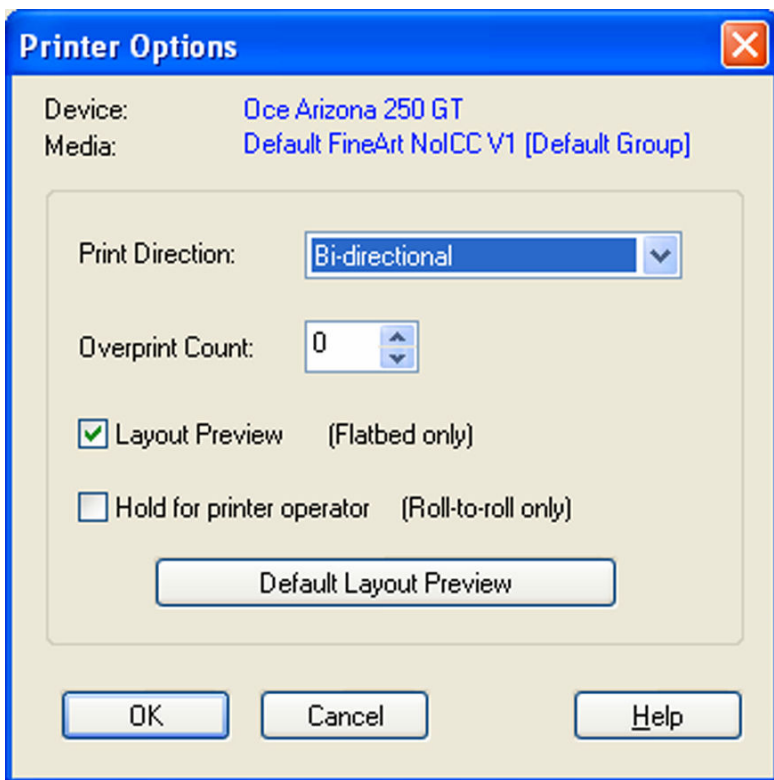

[46] Onyx Roll Hold



NOTE

The Hold for operator is not selected in this illustration since the box is unchecked. If you want to initiate a hold, click it to select.

Printing on Roll Media

Introduction

To print an RMO image, media must be loaded and the RMO initialized. Use the Print Job module and the Roll Media Manager to prepare and start the print job.

How to Print on Backlit Media

If your roll media is transparent or opaque and you are going to backlight the image and you want to increase the density, set Quality mode in ProductionHouse. Then click on the Quality parameter in the Print Job menu and select Quality-Density before you initialize the job. This mode increases the density of ink for this image as it prints and therefore improves the appearance of backlit images.

Note Attention Caution



IMPORTANT

The red Emergency stop buttons do NOT stop the media transport when you print on roll media (they only stop gantry and carriage movement). If you encounter a situation where the roll media runs continuously without operator input, the only recourse is to shut off the printer's AC power switch.

Procedure

1. Click on the Roll icon in the menu bar of the Job Control module to disable the RMO print queue (this allows you to check media parameters before the job actually prints in case the job was not given a Hold status when it was generated in Onyx ProductionHouse).

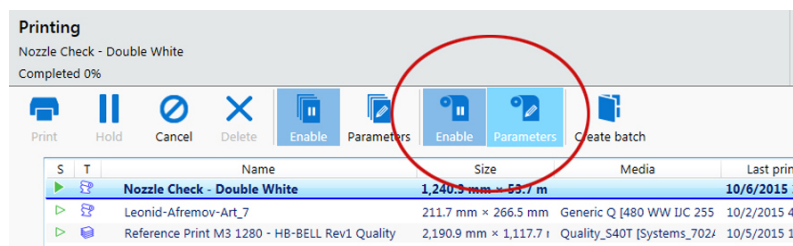

2. In the Print Job Control module, transfer a print job from the ONYX Workflow software.

- Click on the Roll Manager icon to enter the Roll Media Manager dialog window.

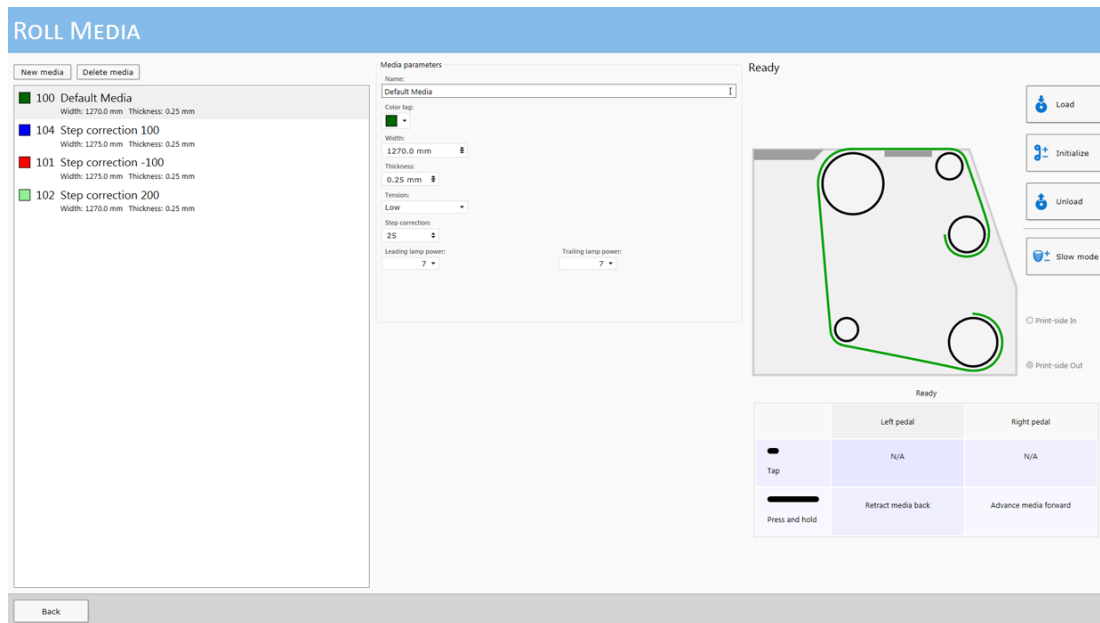

- Enter the Media width for the roll media that you have loaded.

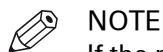

NOTE

If the media width entered is less than 1067 mm (3.5 ft) the standard nozzle check will not fit across the media.

Nozzle Check print: 617.3 x 73.7 (32.03 x 0.24 ft)

- Check that the rest of the media parameters displayed match the particular media you loaded.
- You can create a new media or edit an existing one by changing the parameter values and then saving them under a new media name. When you create a new media it takes the current values as default and automatically creates a unique media name based on the existing name.



NOTE

Any changed parameter in the dialog window will be applied to the next roll media print job, even if the change was not saved. This allows temporary changes to the parameters without the need to save that media.

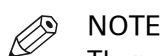
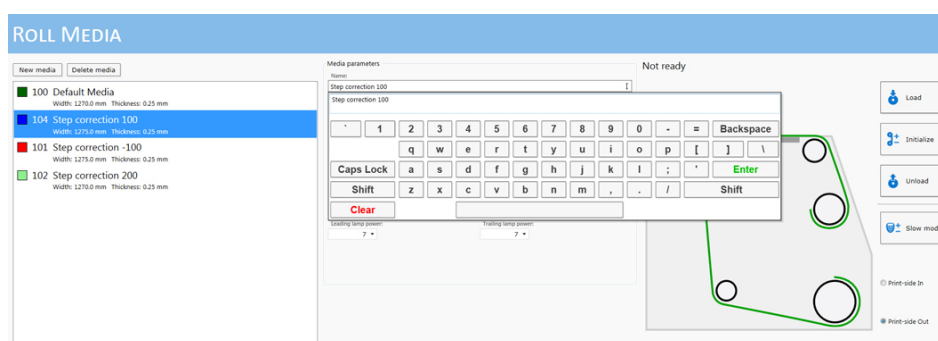

NOTE

There is always at least one media in the list that is called Default Media. It cannot be deleted, but you can change its parameters if you want to use it. If you choose to delete it, the parameters will go back to its original values, but the item will still appear in the list.

- Select the Media Tension

8. Select the Media Advance Correction Factor



NOTE

Leave it at 50 unless you see light or dark lines of banding in the printed image (refer to the next section "How to Set the Media Advance Correction Factor for more details).

9. When the displayed media values are correctly matched to the loaded media, click Close to exit the Media Manager.

10. Click on the Roll icon in the menu bar of the Job Control module to activate the RMO print queue (the icon will change from yellow to green).

Result

Any print jobs that are in the queue, not on hold, and marked as roll jobs will print. There is no explicit confirmation required to start a roll media print job. Any roll media jobs in the print queue will start to print immediately.

Determining the Media Step Correction Factor

Introduction

When you print on roll media, there can be discrepancies in the amount the media advanced during each print swath. This is referred to as media stepping. It can cause banding to occur, in the form of either dark lines or white gaps. The figure below illustrates this banding.

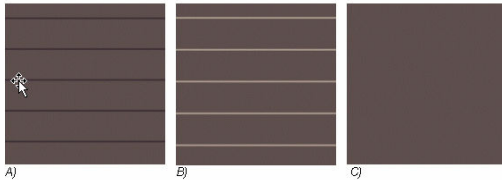

[47] Media Advance Banding

- A) Understep can result in dark lines, where the media has not advanced enough and the placement of a swath overlaps the prior swath. This requires a higher correction factor.
- B) Overstep can result in white gaps, where the placement of a swath is displaced a significant distance away from the prior swath. This requires a lower correction factor.
- C) Perfect Step, where media advances correctly. This requires no change.

Purpose

The Media Step Correction Factor allows the operator to fine-tune media stepping and to optimize print quality.

When to do

This is only required when this particular banding occurs. If you don't see any banding in your images, there is no need to change the value from its default setting of 50.

Before you begin

It is critical to load the media so that the media edge on the feed and take-up rolls are aligned within 1mm.

Using the Media Step Correction Factor: In the 'Roll Media Manager' menu you can select the field **Step Correction** and enter a value from 0 to 100. The default value is 50. You can enter a lower value to correct for white gaps or raise the value to correct for dark lines.

Procedure

1. Put several instances of the Media Step Correction print in the print queue.
2. Print with a default Step Correction of 50 (adjusted in Roll Media Manager).
3. If white lines appear, the media is overstepping. Gradually decrease the Media Step Correction Factor until the white lines start to disappear. Make a note of the Media Step Correction value. Continue to decrease the value until dark lines just start to appear, and note the value. Typically, the average of these two is the ideal Media Step Correction Factor for this media.
4. Similarly, if dark lines appear, the media is under-stepping. Gradually increase the value until the dark lines start to disappear. Make a note of the Step Correction value. Continue to increase the Step Correction until white lines just start to appear, and note the value. Typically, the average of these two is the ideal Media Step Correction for this media.

Media Edge Protectors

Introduction

Some media tend to have dust and fiber that clings to the edge of the media roll. When released near the RMO (Roll Media Option) unit platen, these particles can find their way into the printhead nozzles and cause dropouts that reduce image quality and produce banding.

When to do

When you use roll media that has fibers on the edge of the roll, use the media edge protectors to stop this material from entering the active print area where the carriage moves across the platen. The edge protectors are disposable and are intended to extend the time between printhead cleaning when fibrous media is used.



NOTE

If you use media that is known to have "fuzzy" edges you can sometimes minimize the problem by cutting or burning the debris off.

Required tools

A package of edge detectors is included in the Accessory kit that ships with the RMO unit. If you run out, you can purchase it as a consumable item (see you local sales representative).

Procedure



NOTE

There are both left and right edge protectors and they are both labeled (a left protector has the height adjustor, the arc and the indent on the right side, while the right protector is reversed).

1. Bend the bottom edge of the protector along the first crease (located above the label with the part number) to approx 90 degrees.
2. Bend the other two creases slightly so that they have a V shape when viewed, as illustrated in the side view figure below.

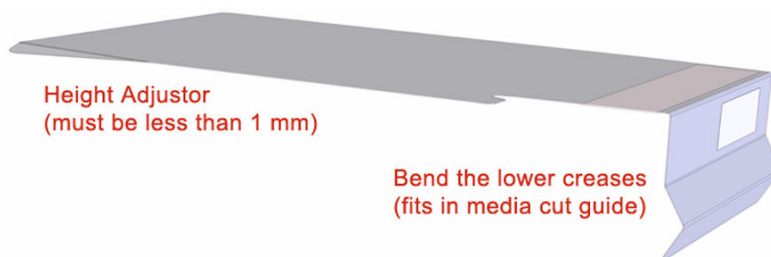

[48] Side View of Media Protector

3. Bend the height adjustor (small triangle in the top corner of the edge protector) slightly and then straighten it again. This results in a slight bend (no more than a media thickness), that allows the media edge to move more freely under the protector.

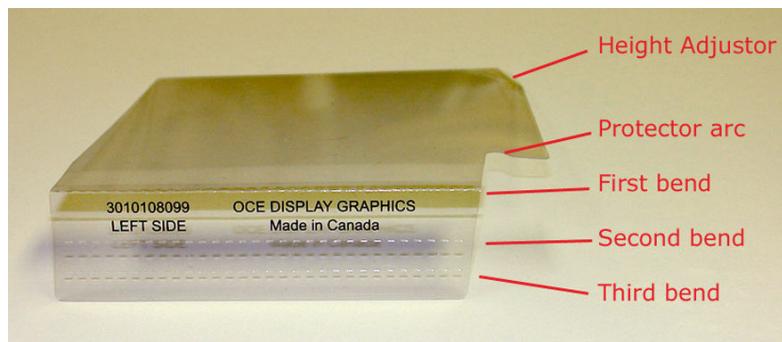

[49] Media Edge Detector Height Adjustor



IMPORTANT

If the height adjustor area is higher than 1 mm from the platen, there is a possibility that the carriage may hit the edge of the protector and thus damage printhead nozzles.

4. Peel the backing layer from the double-sided tape on the back of the protector.
5. Place the bent edge of the protector into the media cut guide, but do not press down on the tape yet.
6. Slide the protector towards the media edge until the inside edge of the height adjustor is positioned over the media edge (see figure below).



NOTE

Do not let the plastic edge near the arc butt up against the media edge or the device may not let the media pass smoothly.

The vacuum in the platen will hold the main part of the protector in place while the image is printed.

7. Press down on the tape to fasten the protector in this position.

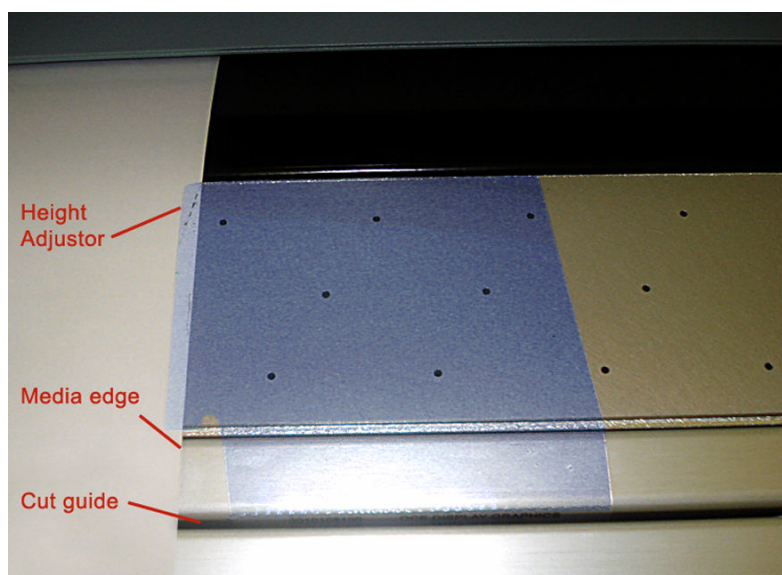

[50] Edge Protector in Position



NOTE

The adhesive on the edge protector can be re-used approximately ten times. If you find that it is not holding the protector in place, then use a new one.

Result

The media edge protectors will reduce the amount of fiber and other debris. However, it is important to keep the platen and cutting guide areas clean as indicated in the Roll Media maintenance section.

How to Deal with Wide Media

If you use media of the maximum width for the RMO (2.2m or 7.2 feet) that requires media edge protection, you can cut the protectors in half in order for them to fit.

Chapter 8

Static Suppression Option

Reduce Static with the Static Suppression Option

Introduction

The Océ Static Suppression Option (sometimes referred to as an Ionizer Bar) is a Commercial Product that can be ordered as part # 3010114574. If you are experiencing static-related imaging problems this optional upgrade kit contains an ionizer bar that provides a solution to reduce static. Some rigid media can have a large static surface charge. If the charge is high enough, ink can be repelled from the media. This ink mist can show up as cloudy areas in white sections of the image. Static not only causes these printing artifacts, but can also result in excessive ink accumulation on the bottom of the carriage.

Purpose

Ionization is a solution to the problem of static. A common print industry method of controlling static electricity is the use of ionization. For the Océ anti-static bar to be effective, it must be close to the media. The bar uses AC current to create positive and negative ions, which are attracted to the unbalanced surface of the material. This neutralizes the media and ink is more readily accepted. It is important to note that static electricity cannot be entirely eliminated; only reduced. To eliminate static electricity, something physically would have to be done to the conductivity of the material.

Humidity is also important to control static. Static-related print issues can be greatly reduced by an increase in print environment humidity. While most media will print without difficulty at humidity levels between 30 and 50%, thermoplastics will print more successfully when humidity is above 40%. Some locales, such as desert areas frequently deal with very low humidity, while other regions only experience this at certain times of the year. If a printer is installed in a low-humidity area and/or a large volume of printed work is on media that is prone to static, we recommend the installation of a humidity control system.

When to do

Why Static is a Problem

Many standard print materials such as PVC and acrylic are electrical insulators, and the static charge generated and held by these materials can provide some printing challenges. Thermoplastic materials are the most common static-laden print media. Static-prone materials tend to attract dust and hair and release charges that can be felt and seen.

How to Activate the Static Suppression ionizing system

Procedure

1. Press the Settings tab on the printer interface screen.
2. Click on the Printer icon.
3. If the Ionizer Bar option is set to Off, set it to ON (this option is not displayed if the option is not installed).



NOTE

Once you have set it to On, it will always automatically turn on at the beginning of a flatbed job. Unless you use media that you are certain does not require static reduction, there is no need to turn it Off as the bar is only active when the printer is printing.

How to Change the Height of the Bar

The Ionizer bar is mounted by default to accommodate media up 13mm (0.5 inches) in height. If you need to use media that has a thickness of greater than 13mm you will have to reverse the mounting brackets. When the brackets are reversed the maximum thickness of media that can be used with the ionizer bar is 38mm (1.5 inches).

Procedure

1. Turn off the printer power switch.
2. Press down on the ionizer bar first from one end and then the other to release the bar from all four brackets.



[51] Remove Static Bar

3. Loosen the bracket mount screw and then slide the bracket up in the keyed slot to remove it.



[52] Bracket Mounted Low

4. Turn the bracket 180 degrees and then fit the other keyed slot over the bracket screw.

5. Slide the bracket mount until the screw is located in the smaller end of the keyed slot.



[53] Bracket Mounted High

6. Make sure the bracket is level and then tighten the bracket mount screw.
7. Repeat Steps 2 to 5 until all four mounts are reversed.

Result

The printer can now use media with a maximum thickness of 38mm (1.5 inches).

Chapter 9

How to Manage a White Ink Workflow

Operator Guidelines for White Ink

Introduction

This chapter is necessary only if your printer has the white ink option.

Managing White Ink

White ink is re-circulated in the system to limit any settling of the ink. For this to take place, **the printer must be left powered on at all times**. Regular maintenance is required to keep the white printheads functioning properly. This may involve additional purge cycles.

Before you begin

If your printer includes the white ink option, a white ink bag must be present in order for the printer to function properly.



IMPORTANT

Daily maintenance is important even when white ink is not being actively used. Failure to perform daily maintenance can result in nozzle dropouts. The purpose of maintenance is to clean the nozzles of the printheads and thus ensure better image quality.

Procedure

1. Agitate the white ink bag gently once a day.
2. Perform Printhead Maintenance for white even if the printer is not used that day.



NOTE

Refer to the Printhead Maintenance section of the Maintenance chapter for an explanation of how to perform daily maintenance.

White Ink Workflow Overview

Introduction

Océ Arizona printers with the White Ink Option provide under-printing for non-white media or objects, over-printing for backlit applications on transparent media and/or printing white as a spot color.

When working with white ink there are three data layers available that allow you to determine the area the white ink will cover and also how it will appear (or not appear) in relation to other colors, depending on the layer it is placed in. You can determine the density of the white ink by altering the drop size. The layer setup is defined in the media model but can be modified as a job printer setting within the ONYX software. When the white ink information is properly prepared according to the methods described in this chapter and the print job is sent from the ONYX software (either ProductionHouse or THRIVE) to the printer, you have an opportunity to verify that the layers are properly embedded in the job.

With the white ink print job selected in the Job Control module of the printer software, click the Layers button to activate a graphical representation of the Print Layers that allows you to verify the layer order.

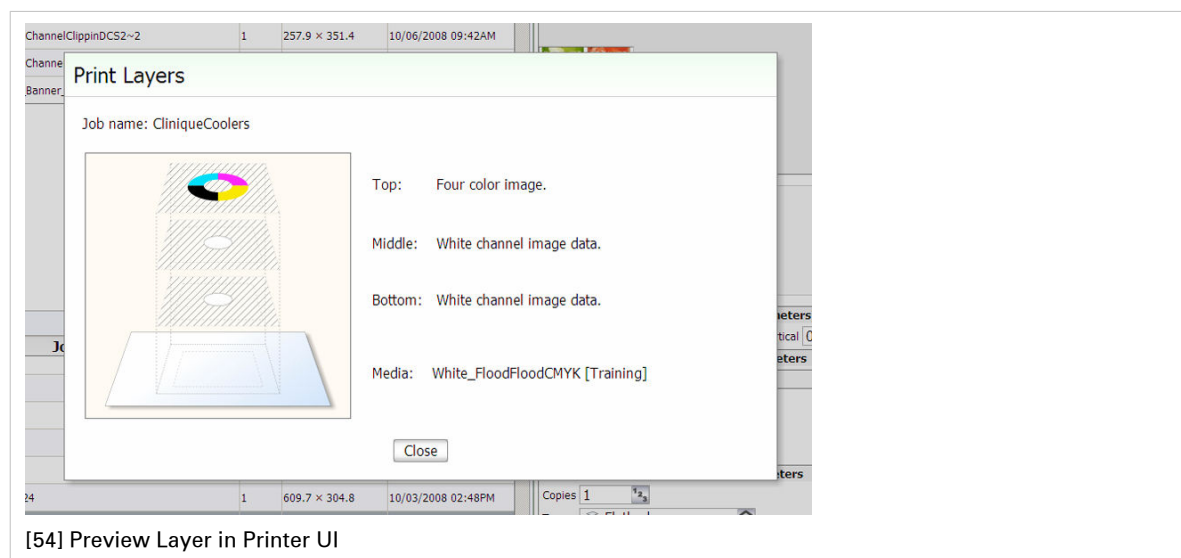

Printer Flood Fill Versus Job Data

White ink can be printed using flood fill data generated by the printer or job spot data. A printer flood fill covers the whole image area while spot data is assigned in specific areas. Job data is separated by the ONYX software into six data planes: C, M, Y, K, Spot 1, and Spot 2. The white ink channels are usually configured to print using the Spot 1 or Spot 2 data plane or a printer flood fill, but can also be printed using the C,M,Y or K data plane.

White Ink Workflow Data Preparation

White ink print job output can be accomplished in a variety of ways depending on the desired results and preferred working process. There are three primary methods and they can be used either independently or all at the same time. The workflow options are:

- Printer Flood Fill Layer Configuration,
- ONYX software Spot Layer Tool, and

White Spot Data Image Preparation.

Printer Flood Fill Layer Configuration in an ONYX workflow does not require any pre-rip file preparation and is the easiest method of achieving white ink output. All that is required is to set up the Layer Configuration to include a printer flood layer. The printer flood layer encompasses the bounding box (the outer border of the image) of the file being processed. There is also an option to control the amount of flood by choosing the drop level. The higher the drop level number the greater the amount of white ink.

ONYX Software Spot Layer Tool offers many options to process an image, and thus allows various possible configuration choices. You can save these configurations as Filters and place them in a Quick Set and this makes it possible to re-create with minimal effort settings that are often used. All work with the Spot Layer tool requires an ONYX media profile with at least one spot color.

White Spot Data Image Preparation requires that the white data be prepared in image editing programs such as Adobe Illustrator®, InDesign, or PhotoShop®. You must use specific naming conventions and image use protocols in order for the Onyx RIP-Queue software to process the data as desired. This method may be the best choice if the desired white ink spot data includes complicated selections or if data is being created for outsourcing. A reasonable level of proficiency in these programs is recommended to use this technique.

All of these methods can also be used either alone or in conjunction with each other to create the desired output results. For example, you may generate the spot layer information for parts of an image in PhotoShop and then go on to specify a Flood Layer Configuration in Production House. This can result in a Flood Layer and a Spot Layer followed by a CMYK Layer. The spot data and the flood will occupy two layers of white density and the CMYK image data can occupy the third layer. You can determine the print order of these layers in ProductionHouse or THRIVE.

Layers can be defined at any of the following locations:

- Defined in the media when the media is created - Mode Options
- Selected in a Quick Set - Media Options
- Modify the printer settings of a processed job in RIP Queue - right-click the job, edit printer settings.

You are not required to use layers when you print white spot data. It can also be printed with print modes other than Quality-Layered.

White Ink Applications

The following are some specific examples of the ways that the white ink workflow can be applied.

White Ink Layer Options

Application	Bottom	Middle	Top	Notes
Backlit First Surface (printing on the front side of the media)	White	CMYK	CMYK	CMYK layers contain same data.
Backlit Second Surface (printing on the back side of clear media)	Reverse printed CMYK	Reverse printed CMYK	White	
Day-Night (First or Second surface)	CMYK	White	CMYK	CMYK data is reversed or right-reading
Opaque	White	White	CMYK	3 layers
Opaque	<empty>	White	CMYK	2 layers

- **Backlit Application**

The backlit application involves printing onto a transparent or translucent material and mounting the finished piece onto a light box or location where illumination from behind is possible. In the backlit application, white ink is intended to provide a light diffusing layer. This application is possible using either 2 or 3 layers.

- **Day-Night Application**

Similar to backlit, the day-night application also involves printing onto a transparent or translucent material. A day-night print can be viewed either front-lit or backlit. This is achieved by printing color data on two separate layers with a white diffusing layer in the middle.

- **Opaque Application**

The opaque application involves printing CMYK data onto non-white media. For this application, white ink is required both to enable the printer to produce images where white forms part of the image content, as well as to act as a base for the CMYK color set.

Varnish Workflow Overview

Introduction

Océ Arizona printers with the Varnish Option can overprint varnish on top of a printed image in select areas in a print job or as a flood coat. The printing of varnish applies only to flatbed printing and is not available with the RMO.



NOTE

The Varnish option is not available for print jobs that use the High Definition print mode. Varnish can be used with all other print modes.

Printing varnish creates a high value-added special effect. However, since this is an additional process after printing image data, it also decreases productivity. Due to the low productivity of printing large areas of varnish, it is best to concentrate the use of this feature on spot decoration. Fortunately, the Arizona printer "blank space" skipping feature skips over areas in the print that do not contain varnish, and greatly improves the net productivity of spot applications.

Varnish is printed as a second process after the CMYKW image is printed. Immediately after printing a CMYKW image. The gantry moves to the start of image position and prints a varnish spot or printer generated flood data using three additional passes.



NOTE

Varnish is actually "clear ink" and is for decorative purposes only. It does not provide additional protection to the printed image.

Spot Versus Printer Flood Fill

Varnish data can be applied to a print job in two ways: Printer Flood Fill or Spot Data.

- A Printer Flood Fill is like an auto-fill that is done by the printer, where varnish data fills the entire bounding box (the rectangular area that defines the total perimeter) of the image.
- Varnish Spot data can be defined in image editing applications such as Adobe Illustrator® or with the Spot Layer tool in the ONYX workflow.

The Spot Data can be defined as either Spot 1 or Spot 2. The same spot data can be used to print either varnish or white ink, or both.

Varnish Workflow Data Preparation

Varnish print job output can be accomplished in a variety of ways depending on the desired results and preferred working process. There are three primary methods. The workflow options are:

- Printer flood fill configuration,
- ONYX software Spot Layer Tool, and
- Varnish spot data image preparation.

Printer Flood Fill Configuration in the Onyx workflow does not require any pre-rip file preparation and is the easiest method of achieving varnish output. All that is required is to configure ONYX to use a Varnish Flood. The printer flood encompasses the bounding box (the outer border of the image) of the file being processed.

ONYX Software Spot Layer Tool offers many options to process an image, and thus allows various possible configuration choices. You can save these configurations as Filters and place them in a Quick Set and this makes it possible to re-create with minimal effort settings that are often used. All work with the Spot Layer tool requires an ONYX media profile with at least one spot color.

White Spot Data Image Preparation requires that the varnish data be prepared in image editing programs such as Adobe Illustrator®, InDesign, or PhotoShop®. You must use specific naming conventions and image use protocols in order for the ONYX RIP-Queue software to process the data as desired. This method may be the best choice if the desired varnish spot data includes complicated selections or if data is being created for outsourcing. A reasonable level of proficiency in these programs is recommended to use this technique.

Configure ONYX Software for White Ink

Introduction

This section describes how to configure ONYX software (either THRIVE or ProductionHouse) to recognize white ink workflow elements and thus allow you to apply the approach that is best for your print job application. In order for the ONYX software to successfully address white ink workflow data, there are options in the software that must be configured. It also explains how you need to use specific ONYX media profiles to prepare white ink print jobs.



NOTE

Step 1 and 2 below are required for ProductionHouse only. Step 3 is needed for both ProductionHouse and THRIVE.

Procedure

1. Within Rip-Queue, access the Configure Rip Options Palette.

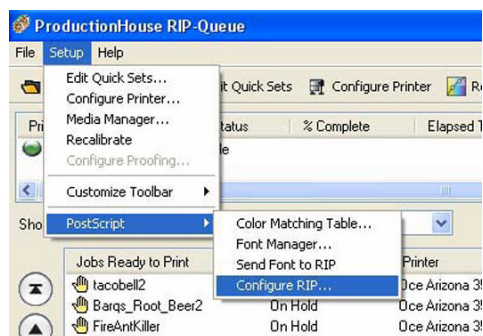

[55] Set up ONYX RIP

2. Once here, ensure that Overprint is turned on (checked).

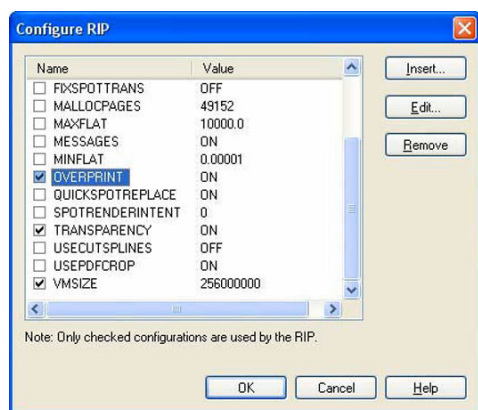

3. In your Quick Set, or in Preflight/Job Properties/Postscript turn off two-stage processing (make sure the box is not checked).

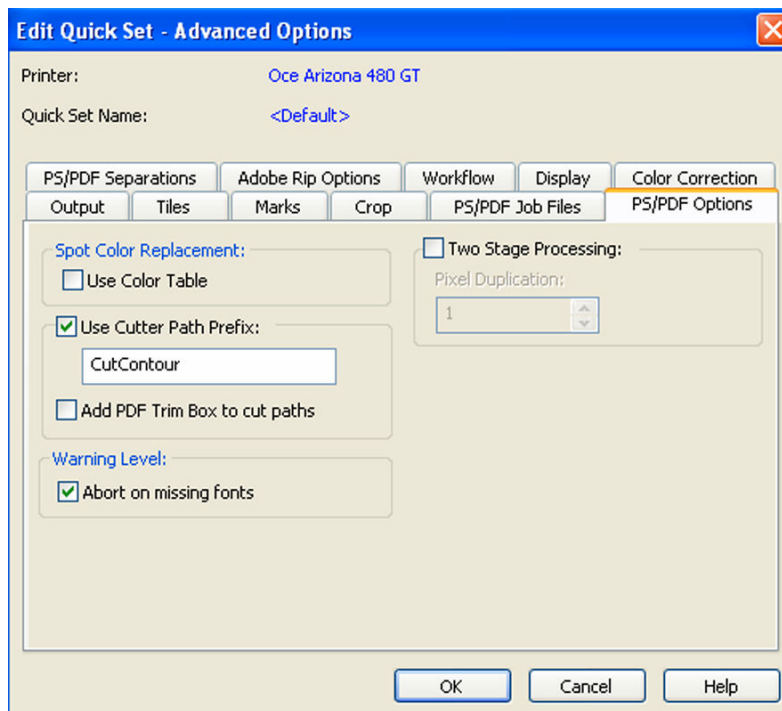

[56] Turn off Two Stage Processing

ONYX software will now accept print jobs with white ink or varnish data. To prepare a print job for white ink you need to use an ONYX media profile (media model) as shown below.

White Ink ONYX Media Profiles

Introduction

White Ink print jobs require media profiles with a particular ink configuration and spot colors defined. Media profiles for your printer are available from the DGS website: <https://dgs.oce.com/>

White Ink ONYX Media Profiles

Océ Arizona Quality-Layered print mode is used to print white ink applications such as under-printing for non-white media, over-printing for backlit applications viewed 2nd surface or as middle layer for a day-night application.

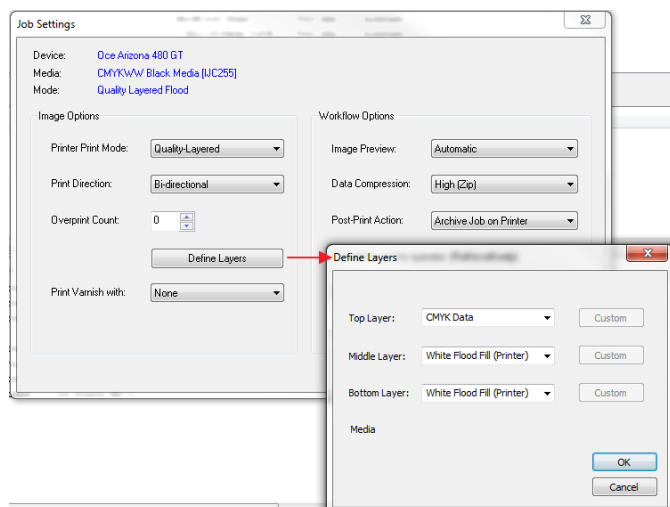

Print modes other than Quality-Layered mode can also be used to print only white ink, or areas of white ink in an image, as long as the ONYX media profile (media model) has been made with a CMYKSS ink configuration with spot colors defined.

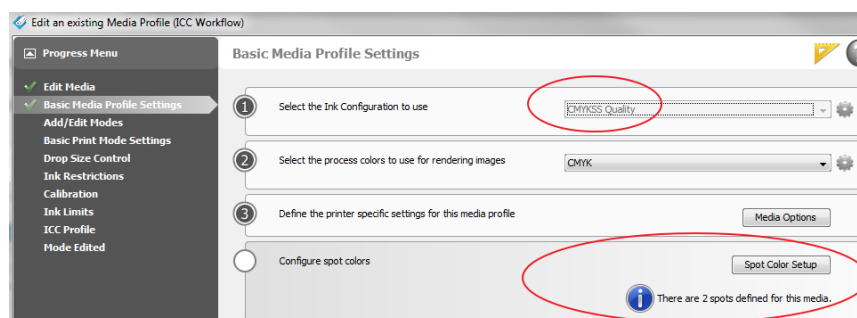

NOTE

When printing white ink using print modes other than Quality-Layered, it is not recommended to print white ink in the same area of an image as CMYK inks. The white ink does not mix well with the other ink colors.

How to Prepare White Ink/Varnish Print Jobs

Select the Best Workflow

Introduction

When working with white ink you can choose the workflow that best fits your needs. There are three main approaches to white ink workflow with your printer:

- **Printer Flood Fill Mode** - uses the Printer Flood Fill Configuration.
- **ONYX Spot Layer Tool** - generate the white spot data in ONYX ProductionHouse or Thrive.
- **Spot Data (pre-defined)** - spot data is created in image editing application such as Adobe Illustrator, InDesign, or PhotoShop.

The sections that follow will explain how to prepare images for these three different workflow approaches to white ink.

How to Setup a Printer Flood Fill

Prepare a Printer Flood Fill

With the Printer Flood Fill approach, white ink is set up as a layer that is embedded in the print job.

Purpose

The Printer Flood Fill mode allows you to print an image with a white flood fill as an underlay or an overlay. The edges of the image bounding box (the outer perimeter of the image) will determine the extent of the flood fill area.

When to do

This approach is used when an image is rectangular in shape and requires a white flood fill. The printer itself provides the flood fill rather than the ONYX Spot Layer Tool or an image editing application, so no additional data preparation is required.



NOTE

If jobs are nested in the ONYX software, white is printed between jobs when you use this technique because the outer extent of the entire nested job is used to define the flood area.

How to Print a White ink Flood Fill Layer

Refer to the section "White Ink QuickStart" for more details.

How to Create Spot Data with the Spot Layer Tool

Introduction

The Spot Layer Tool can be used to set up two spot data planes that define areas where Spot 1 and Spot 2 data are added to a print job. The tool is used with the Océ Arizona printers that both have two extra channels to provide varnish or white ink as well as with CMYK only printers. Both white ink and varnish can be printed using either Spot 1 or Spot 2 data. The same spot data can be used to print either white ink, varnish, or both.

In this section, you'll learn how to access and set up the Spot Layer Tool. The tool provides a variety of options for generation of spot layers, and you may want to explore them with a sample file of your own to familiarize yourself with the functionality. Remember that any actions you set for this tool will only work successfully when used in conjunction with properly constructed layers. The tool is located in Preflight on the Color Correction tab.

The Spot Layer Tool provides options for generating spot layers for your image in ProductionHouse rather than in image editing programs such as Illustrator or Photoshop. The tool has many advanced options and this section will explain them so that you can set them up to best achieve your desired results. The tool options and settings to use it for spot data creation are listed here and are followed by instructions to access the tool.

How to Use the Spot Layer Tool

The Spot Layer Tool Provides These Options:

Generation Options - Set Media

Set media color is optional and serves two purposes:

- If you want to preview the media color in Preflight, you can set the media color either from the image or from the color dialog menu.
- If you have areas in your image that use the media color and you want that color to be handled with special consideration. For example; if you want the media color from the image to show through the design, you must first define your fill options, then set the media color and define the Media Color Handling Options as either "Spot Knockout" or "Full Knockout".



NOTE

The generation options are used in combination with the fill options, except when the media color handling is set to "No Knockout". If you want to use the Spot Layer Tool to create flood fills, underlay fills or mask fills it is not always necessary to set a mask or media color to get the desired results.

To set the media color: Click the sample box to activate the color picker or use the drop down arrow to access the Color Dialog menu.

Generation Options - Set Mask

The mask allows you to determine the area that you wish to print with spot data. Setting the mask color is optional. If the image you are printing contains white or varnish data in more than the mask area, you will need to set up a different background color not used anywhere else in the file to use as your mask. This must be done in an image-editing program prior to bringing the image into the Spot Layer Tool.

To set the mask color: Click the sample box to activate the color picker or use the drop-down arrow to pick the color from the preview.

Generation Options - Media Color Handling

If you have set a media color, you have three options for how you would like the media color to be handled. The term “Knockout” means to remove from the selection. If you’ve set a media color, chances are you want some portion of the design to be removed to use the media color. These are the option you have to choose from:

- No Knockout - If you’ve set a media color to help you visualize your output, choose this option. This will print the image and spot data with no knockout.
- Spot Knockout - If you choose this option, RIP-Queue removes the spot data anywhere the image data matches the media color that you set. Use this option when you want to knockout the spot data but still print the image data that matches the media color.
- Full Knockout - If you choose this option, RIP-Queue removes the spot data and the image data anywhere the image data matches the media color that you set. Use this option when you want to knockout the spot data and the image data, allowing the media to fully show through.

Spot Channel

The Océ Arizona 460, 480, and 660 printers have two spot channels available. The names that appears here should be the ones you used to create the media in Media Manager. The recommended spot channel names are: "Spot 1" and "Spot 2".



NOTE

ONYX software treats Spot 1 and Spot1 as equivalent. The space between "t" and "1" is not important but the case is, so the "S" must always be capitalized.

Flood Fill

This option generates a flood fill for the entire image by combining the underlay and mask fills together. When you check this option, the underlay and mask fill sliders lock together and are set at 100%. You can change the opacity for the flood fill by moving either of the sliders.

Underlay Fill Opacity

This option generates a fill in the selected spot channel where image data exists. The fill will be generated anywhere image data does not match the mask.

Mask Fill Opacity

This option generates a fill in the selected spot channel where mask data exists. The fill will be generated anywhere the image data matches the mask color.

Choke and Spread

Choke reduces the outer edge of the underlay. Use choke when you want to eliminate white from peeking out of the edge of your image. Spread increases the outer edge of the underlay fill. Use spread when you want a deliberate halo around the edge of your image. Choke and Spread work in tandem. Each mark on the slider represents 1 pixel width of choke or spread up to 10 pixels (+-). The actual preview in Preflight is exaggerated from what is printed. This exaggerated display makes it easier for you to see the results from moving the slider. When you use the Spot Layer Tool for masks, we recommend a choke value of 3 ticks.

Diffuse Edge

Use this option when you want a gradual transition from the underlay to the mask to create a soft edge for the fill. We do not recommend use of this option.

Filter

Once you’ve defined your settings, save them by exporting a Filter to use on similar jobs. Filters are a global color correction that can be applied to Quick Sets to automate the printing process for multiple jobs that use the same settings.

Note Attention Caution



NOTE

Many of the Quick Set and Filter settings for a job can be overridden in RIP-Queue or Preflight, if desired.

Procedure

This manual assumes that you have some experience with graphics applications and with ONYX software. If you prefer a self-guided and hands-on tutorial, Customer Application Bulletin 22, "How to Use the Spot Layer Tool for White Ink Workflow" provides a simplified method to print with white ink (it does not mention varnish, but the same principles apply). It guides you through a simple tutorial that shows how to prepare an image for quick and easy white ink print production with spot data. You will learn how to isolate the white area of your image in Illustrator so that it will be recognized by the Spot Layer Tool and then printed as white by the printer. Download Application Bulletin 22 from the Customer Support web site: <https://dgs.oce.com>.

How to Access the Spot Layer Tool

Procedure

1. Open a print job in Preflight using an ONYX profile (media model) that contains spot data channels.
2. Select the Color Corrections tab.
3. Click on Tools and select Spot Layer Tool. This will open the feature set.



NOTE

If the Enable checkbox won't activate, the media you used to open the job has not been configured with the Quality-Layered print mode. Create or Edit your media to support spot ink in Media Manager before you open the job in Preflight (or download a white ink media model from the website).

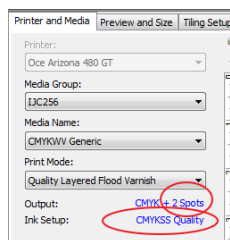

[57] ONYX Profile with Spot Channels

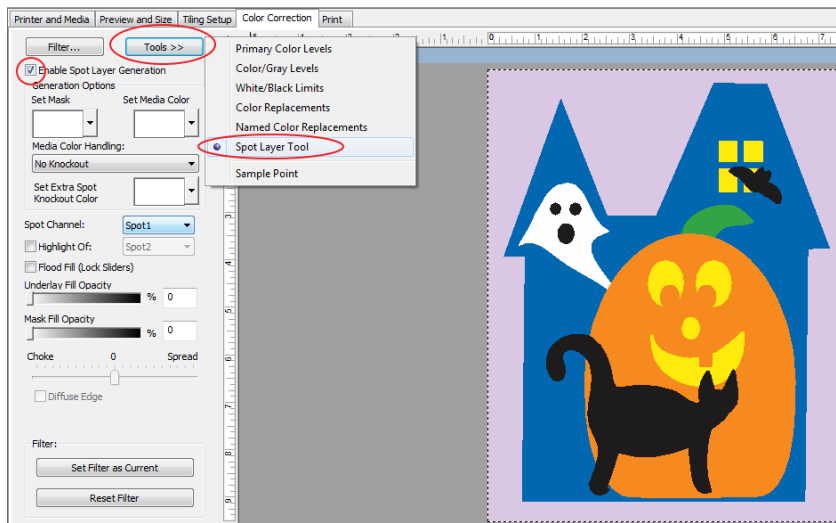

[58] Select the Spot Layer Tool

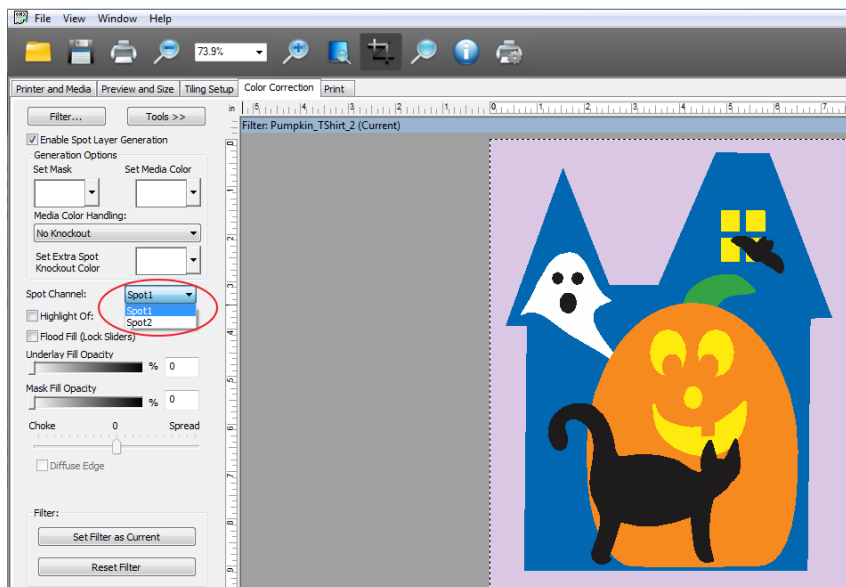

[59] Spot Channel Selection

4. Check Enable Spot Layer Generation to activate the tool.
5. Select the spot channel you will use to create data, then use the explanations of the Spot Layer Tool options at the beginning of this section to help you use the tool.

How to Create Spot Data in Photoshop

Introduction

This section explains how to prepare images that include spot data with raster-based image editing applications such as Adobe Photoshop®. In order to print with white ink or varnish, you must have an ONYX profile (media model) properly configured for the use of spot data.

To add spot color data to your image in PhotoShop, you need to create a layer within the image as a new spot channel. It is possible to have more than one spot element in an image, but each element must be on the same spot channel, and therefore have the same opacity level, or else ProductionHouse will treat the saved document as a separation file. Since the Arizona printers with white ink or varnish support two spot channels, you can create one spot channel for Spot 1 data and another for Spot 2 data. CMYK is the preferred image mode as the actions required for spot data creation are simpler than those for RGB.



NOTE

You can use raster-based image editing applications other than Photoshop as long as it has the ability to create spot channels.

Purpose

When you have a raster-based image and need to have select areas of that image show up as white when the media is non-white or clear or translucent, you can prepare a spot channel for the white data in Photoshop.

When to do

The first step in the white ink or varnish workflow is to prepare your source image to use a spot ink channel. The spot data must be designed entirely on a separate channel (either as a spot channel layer or a custom spot color) to be recognized by the Onyx RIP. The name you assign to this spot channel layer or custom spot color must be Spot 1 or Spot 2 and is the most important part of preparing the file. This named channel allows RIP-Queue to determine that the data in the source image needs to be output to the spot channel. In preparing your file, only you can define what you want to print with "white ink" or "varnish" as part of your design and assign the color as described in this document. Using your graphic application program, the spot data can be simple or complex and can range from vector shapes and text to halftone bitmap images.

New Spot Channel Layer

Use the following steps to create a new spot channel layer:

Procedure

1. Open the desired file in PhotoShop (if the file is in RGB mode, then convert it to CMYK mode).
2. Use the desired selection tool (e.g. the Magic Wand) to select the area of the image you wish to print with white ink.



NOTE

The image file used in this example is for illustration purposes only. For best results when working with text, we recommend that you use a vector-based program such as Adobe Illustrator.

3. In PhotoShop, ensure that the Channels tab is visible (under the Window menu click Channels to view the panel).
4. Click the arrow on the Channels tab to display the Channels menu.

5. Select New Spot Channel from the Channels menu to open the Add Spot Channel dialog.

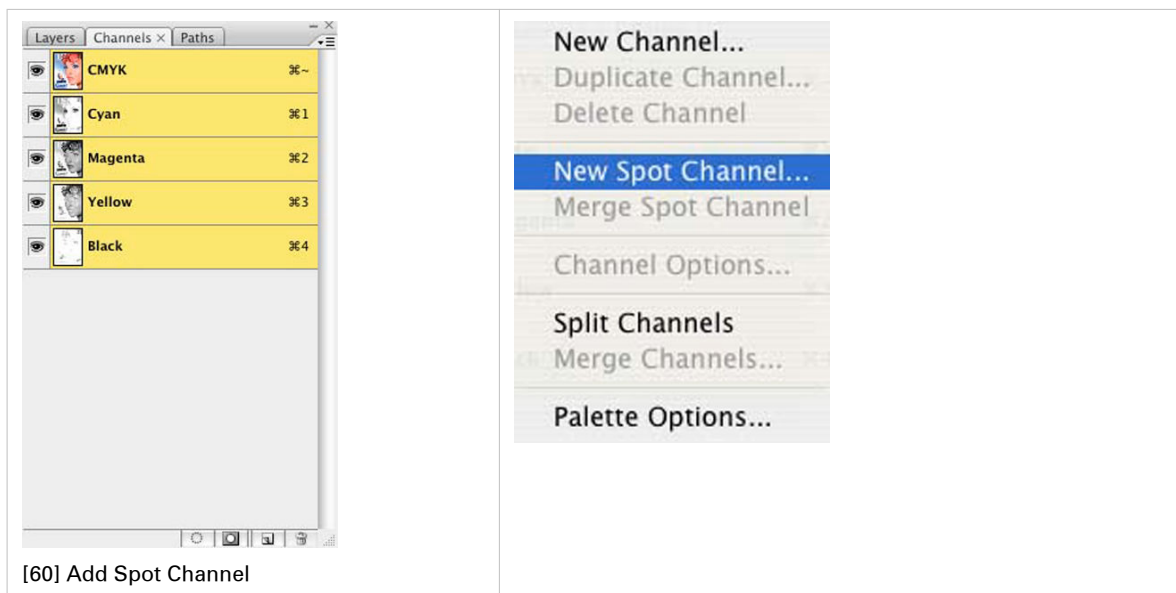

6. Within the Add Spot Channel dialog, enter the following information:
 - **Name** – Enter the name "Spot 1" or "Spot 2". This name is specifically reserved in RIP-Queue for this type of workflow, using any other name requires more steps to make spot information addressed by the Rip software.
Note: For instructions on how to use a naming convention other than Spot 1 or Spot 2, refer to the sub-section at the end of this section "How to Name Your Spot Data".
 - **Opacity** – Set the opacity to 10%
 - Edit the channel **COLOR** by double-clicking on the swatch. Set the spot color in PhotoShop to a color similar to the spot ink in your printer. Since white can be hard to distinguish, this COLOR can be any value that will help you see the design better.

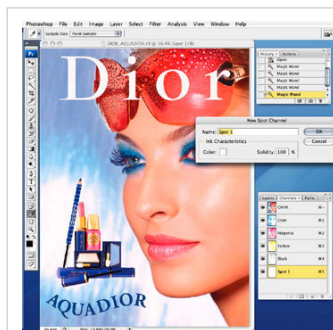

[61] Select Spot Color

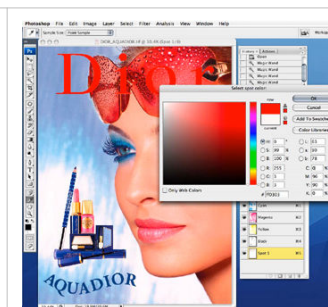

[62] Change Spot Color

7. Click OK to save your changes and close the Add Spot Channel dialog.
8. You can create a flood layer in the same way by selecting the entire workspace (Select All) and then add the spot channel as described above. The example below shows what your workspace

may look like with a 50% and 100% flood fill. If you need to see your image for editing purposes, simply turn off the visibility of the Spot Channel.

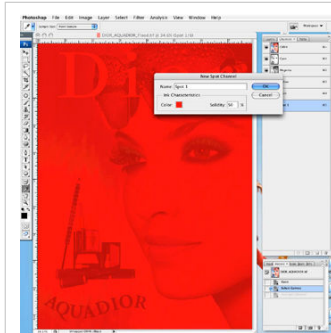

[63] Flood 50 PSD

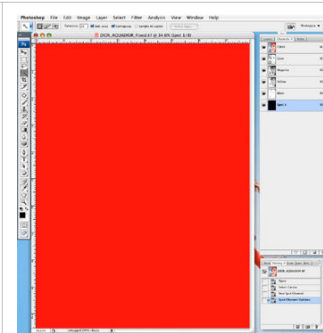

[64] Flood 100 PSD

9. In some cases, it may be easier to select the area in which you don't want any white ink data and then select the inverse.

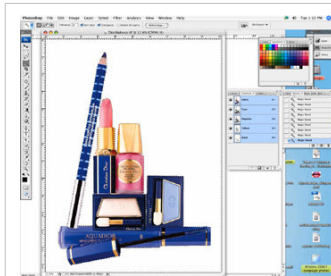

[65] Select

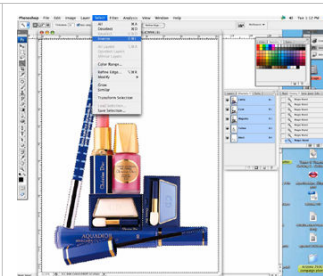

[66] Select Inverse

10. It is also possible to edit the spot channel much as you would any other data in a PhotoShop document, making use of such tools as the Eraser.
11. Save your image as a either a TIFF or PSD format file (see the points below to determine the best format).

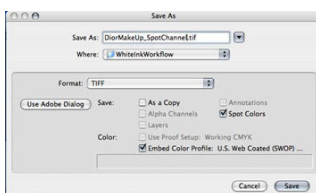

[67] Save with Spot Option

- If you intend to use this file in a vector-based program such as Illustrator, save it as a .PSD file in order for all channel information to be carried over. The white spot color is printed in the order it appears in the Channels palette, with the spot channel printing underneath CMYK data. However, when exported as a .PSD to Illustrator, this data will appear above the image data. This is the correct format protocol for Illustrator.
- Save as TIFF and ensure that the spot colors option is enabled if you plan to bring this image directly into ProductionHouse.
- It is also possible and sometimes preferable to print directly from PhotoShop to Rip-Queue. For instructions on how to do this, see document provided on the Onyx web site "Printing From a Mac", which also contains information on printing from Windows-based systems.

How to Prepare Spot Data in Adobe Illustrator

Introduction

This section explains how to prepare images that include spot data with vector-based image editing applications such as Adobe Illustrator®. In order to print with white ink or varnish, you must first have an ONYX profile (media model) properly configured for the use of spot data.

To add spot color data to your image in Illustrator, you need to create a layer within the image as a new spot channel. It is possible to have more than one spot element in an image, but each element must be on the same spot channel, and therefore have the same opacity level, or else ProductionHouse will treat the saved document as a separation file. Since the Arizona printers with white ink or varnish support two spot channels, you can create one spot channel for Spot 1 data and another for Spot 2 data. CMYK is the preferred mode as the actions required for spot data creation are simpler than those for RGB.



NOTE

You can use vector-based image editing applications other than Illustrator as long as it has the Overprint feature and the ability to create a spot color.

When to do

The first step in the white ink workflow is to prepare your source image to use the spot channel. The spot data must be designed entirely on a separate channel (either as a spot channel layer or a custom spot color) to be recognized by the Onyx RIP. The name you assign to this spot channel layer or custom spot color must be Spot 1 or Spot 2 and is the most important part of preparing the file. This named channel allows RIP-Queue to determine that the data in the source image needs to be output to the spot channel, in this case the white ink or varnish channel.

In preparing your file, only you can define what you want to print with "white ink" or "varnish" as part of your design and assign the color as described in this document. In Illustrator, the white ink data can be simple or complex and can range from vector shapes and text to placed bitmap images.

Use the following steps to configure an Adobe Illustrator file for use with white ink:

Procedure

1. In Illustrator, ensure that the Swatches tab is visible (under the Window menu click Swatches to view).
2. Click the arrow on the Swatches tab to display the Swatches menu.
3. Select New Swatch from the Swatches menu to open the Add Swatch dialog.

4. Within the Add Swatch dialog, enter the following information:

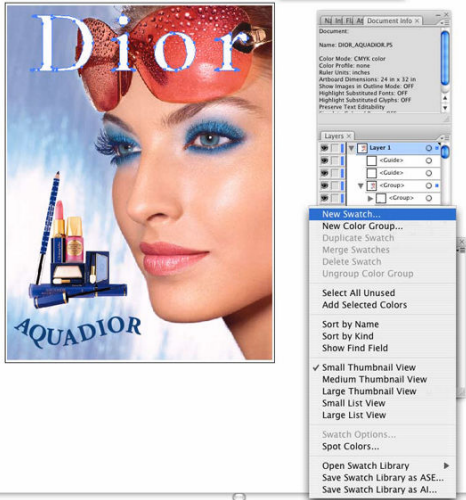

[68] New Swatch

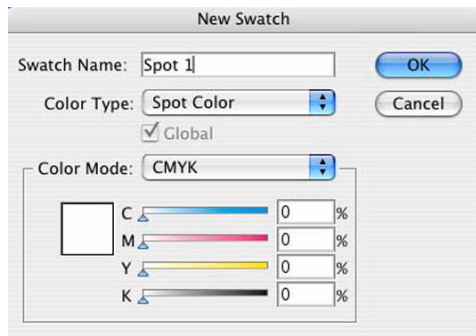

[69] New Swatch Name

- **Name** – Enter the name Spot 1 or Spot 2.
Note: For instructions on how to use a naming convention other than Spot 1 or Spot 2, refer to the sub-section at the end of this section "Naming Your Spot Data".
 - **Color Type** – Use the drop-down menu to select Spot Color.
 - **Swatch Color** – Use the sliders to adjust the swatch color. You can make this color any value that will help you see the design better.
5. Click OK to save your changes and close the Add Swatch dialog. You should now have a new Spot color in your swatch palette, which is indicated with a small dot on bottom right side of swatch.

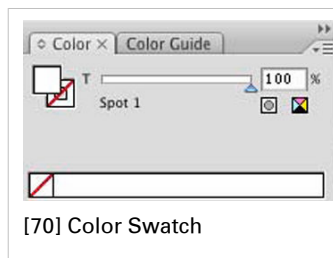

[70] Color Swatch

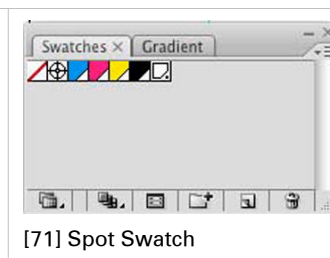

[71] Spot Swatch

How to Overprint Spot Data in Illustrator

6. Use the new swatch for any objects or fills which need to be printed with white ink. Clicking on new spot color swatch will make this the default fill color for this document. Select element you would like to be treated with Spot information and choose the fill swatch. See the example below.

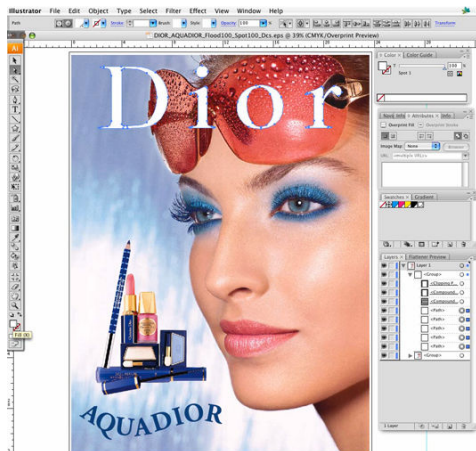

[72] Select Spot Fill

7. Once you've configured your source image with white ink or varnish as your new spot color, save your work.

How to Overprint Spot Data in Illustrator

Set Up Overprint

By default, when you print opaque, overlapping colors, the top color knocks out (cuts a hole) in the area of colored image underneath. Overprinting prevents knockout and allows the colored image data to print over top of the other color being used, which in this case is white. You will want to overprint when the artwork needs to be printed over top of white, usually if the substrate material is non-white and therefore white is required to accurately render image data.

Procedure

1. Select the spot data object or objects that you want to overprint and place these above the image data layer that you would like to print. Or if you want them on the same layer the spot data objects should be in front of the image data.

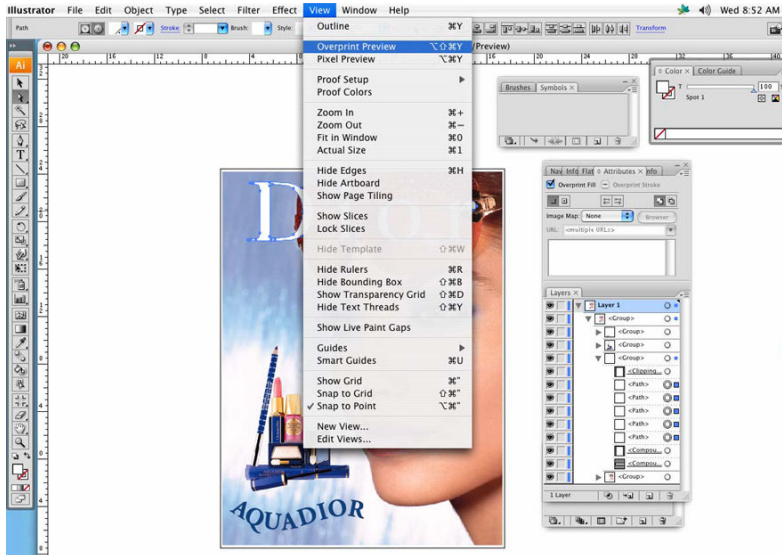

[73] Overprint Preview



NOTE

After you set overprinting options, you should use the Overprint Preview mode (View > Overprint Preview) to see an approximation of how the overprinting colors will print by providing an "ink preview" that approximates how transparency and overprinting will appear in output.

2. In the Attributes panel, select Overprint Fill, Overprint Stroke, or both.



NOTE

While it is possible to set Overprint opacity levels less than 100%, ProductionHouse software only processes full opacity data. The opacity of regular knockout spot data can be set as desired.

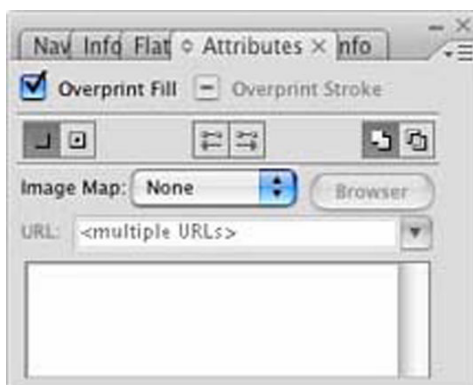

[74] Overprint Attributes

The images below shows white spot data with knockout and overprinting. In this case the spot data is meant to knockout in order to appear as white in the final document.

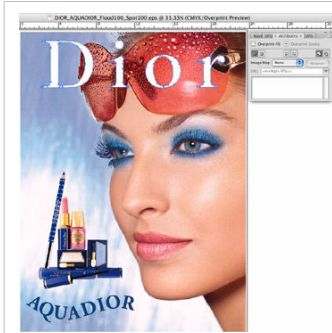

[75] Knockout

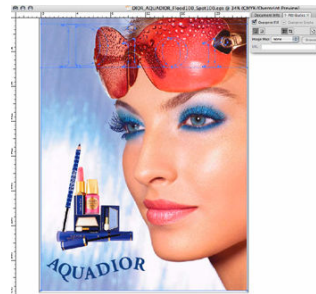

[76] Text Overprinting

Spot Flood Fill Layers

If a spot flood layer were required in this file, it would be necessary to place flood data above the image data layer in order for the Rip to properly process the Spot data. In this case, you would need to select Overprinting, in order for image data not to be obliterated by spot flood. To properly view the image ensure that Overprint Preview is selected. See images below for a representation of how this will appear.



NOTE

When processing this file in ProductionHouse, media layers must be set up with a spot layer to represent this data, as Illustrator identifies this as a Spot, rather than a flood layer.

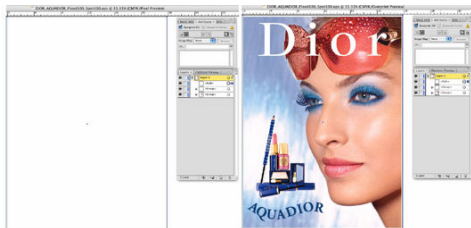

[77] Pixel Preview Flood

How to Place Raster Images in Illustrator

Procedure

1. Begin by placing the desired file. We recommend using .PSD files.

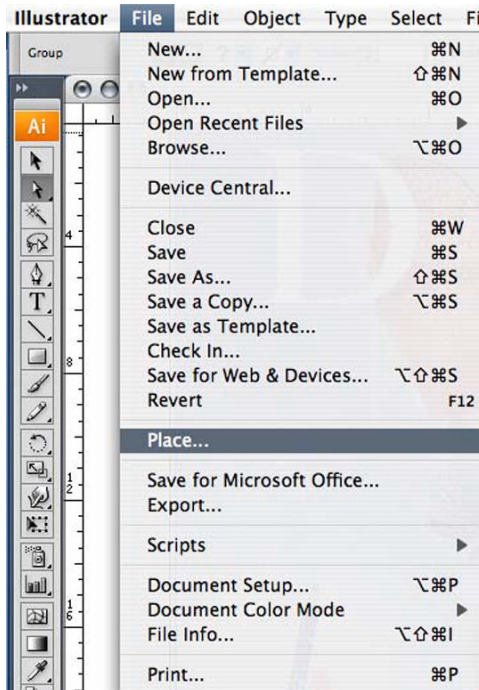

[78] Place File

2. Once the file has been brought into program, click the Embed button to place it in the Illustrator document. This step is necessary in order to make use of all channel data contained in the file.



[79] Embed File

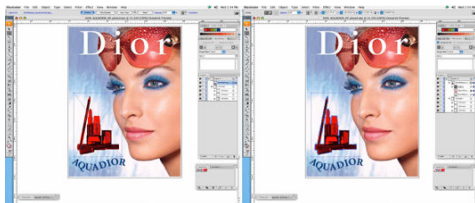

[80] Embed Placed

3. Note the information contained in the layers palette for file before and after embedding. Spot Channel data now resides in the layer above the image data, which is the necessary protocol in Illustrator.

How to Create a Spot Channel Path in Illustrator

Conversely, you may place a raster file in your Illustrator document and create Spot data in Illustrator using the path creation tools. Create your path using the data as your guide and once the path is completed, fill this path with your Spot 1 or Spot 2 color. This filled path should be placed above image in layers palette. In this particular case, the complexity of the selection path may dictate it's creation in PhotoShop, and Illustrator may be better used for simpler objects.

Procedure

1. First, select your clipping path and make a copy of it.

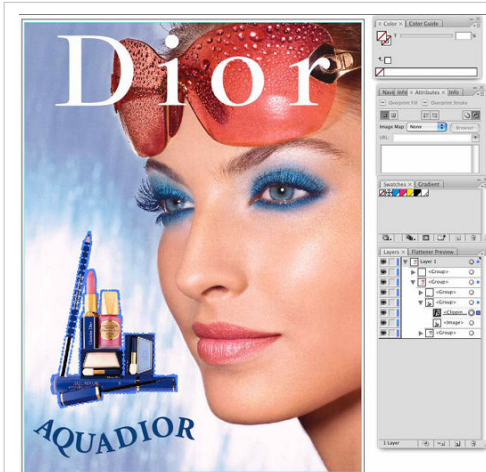

[81] Select Clipping

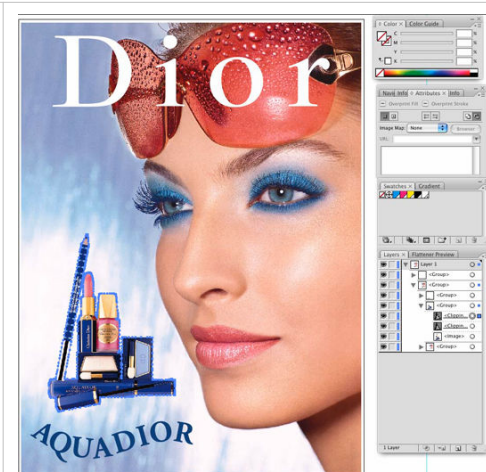

[82] Copied Path

2. Then move the new layer outside of the group it is in to un-link it from the clipping path.

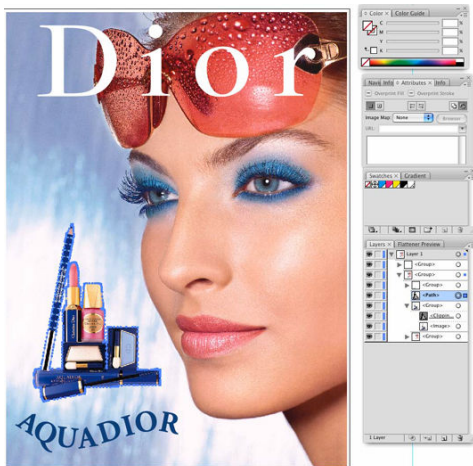

[83] Moved Channel

3. Once outside the group, make sure path is selected and fill it with your Spot 1 or Spot 2 color.

- Once that is done, replace path in the group above the image and clipping layers. Ensure that Overprint is turned on.

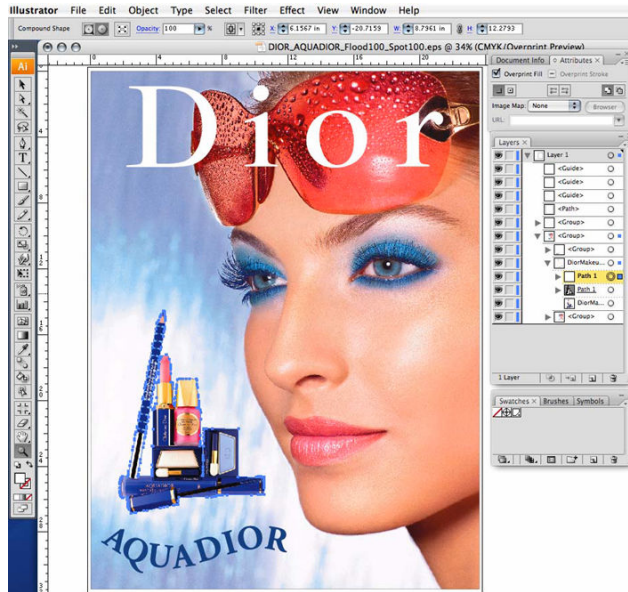

[84] Replace path in Group

- Save the file.



NOTE

In testing, we have found the .eps file format to be the best. However, Postscript and PDF files will work as well, but may require some additional setup. Make sure that when you save the file, "Preserve Overprints" is enabled.

It is also possible and sometimes preferable, to print directly from Illustrator to Rip-Queue. For instructions on how to do this, see the Onyx web site for a document called "Printing From a Mac" (it also contains generic information on printing from Windows-based systems).

- Open the file in ProductionHouse.

How to Set Up a File for Preflight's Spot Layer Tool

The Spot Layer Tool in Preflight can also make masks for data, and in some cases may be the preferred method of spot layer creation. To ensure that mask selection is made in Preflight without selecting those parts of your image that are of the same color, it is necessary to create a layer in Illustrator to serve as the mask.

Procedure

1. Create a box around your image using the Rectangle Tool or other appropriately shaped box tool.
2. Make sure this new box is selected and select Fill swatch located at the bottom of the Illustrator toolbar. This will fill the box with color. By double clicking on this swatch a dialog box will open allowing for color changes. Ensure that the chosen color does not appear anywhere in your image. For this example we have used red (composed of 100% Cyan and 100% Yellow).
3. Place this rectangle behind your image data, either underneath or in a new layer below. It is not necessary to choose Overprint attributes for this layer.

Result

The prepared file should look similar to the example below.

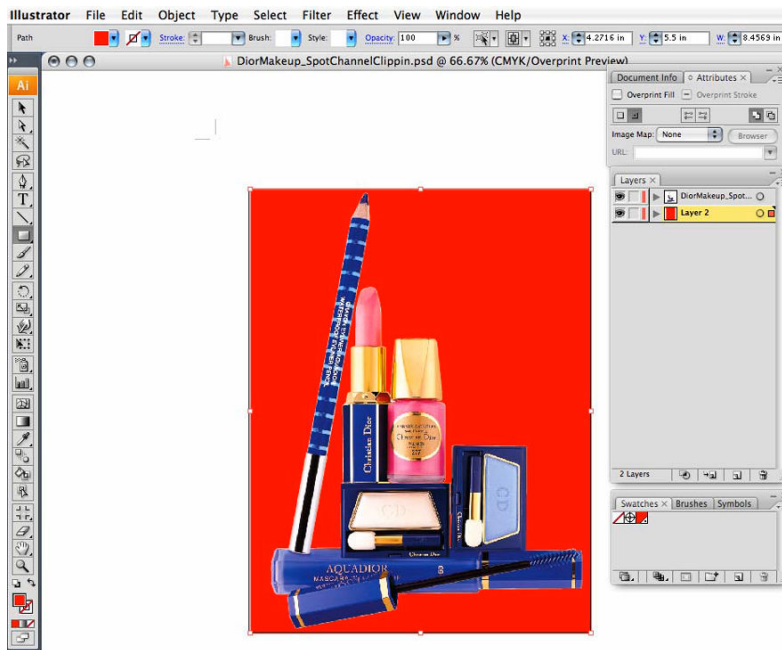

[85] Red Mask

How to Name Your Spot Data in Illustrator

In order for ProductionHouse to correctly distinguish and address Spot data, naming conventions for this data must be adhered to both in the image editing creation stage and the Rip. While using the default name Spot 1, is the simplest route requiring the fewest number of steps, there may be instances when using something other than this is desirable. For instance, when data is created by one individual and printed by another, naming spot data may make desired output results more clear. As well, if English is not your native language, use a name that is more meaningful in your language to be more effective. Please do not use the name "White" as this color flags ProductionHouse to be treated in a particular manner not desired for this workflow.

Procedure

1. When you create a new Spot Swatch in Illustrator, edit the name and replace it with your preferred name.

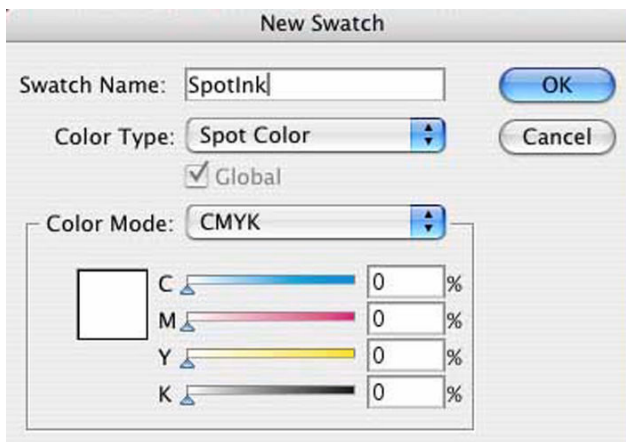

[86] Spot Ink Swatch

2. Edit the media to be used for this data in Media Manager, replacing the default name Spot 1, with your newly created name.

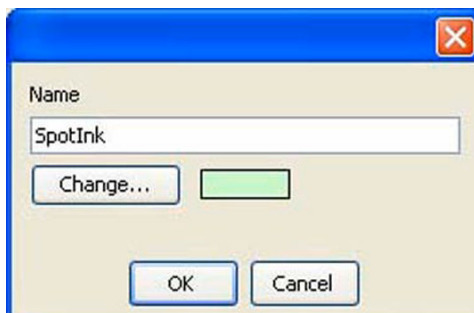

[87] Change Name

3. Open file in Preflight and access the Color Management/Edit Profiles tab. Click on Spot Channel Replacement box.

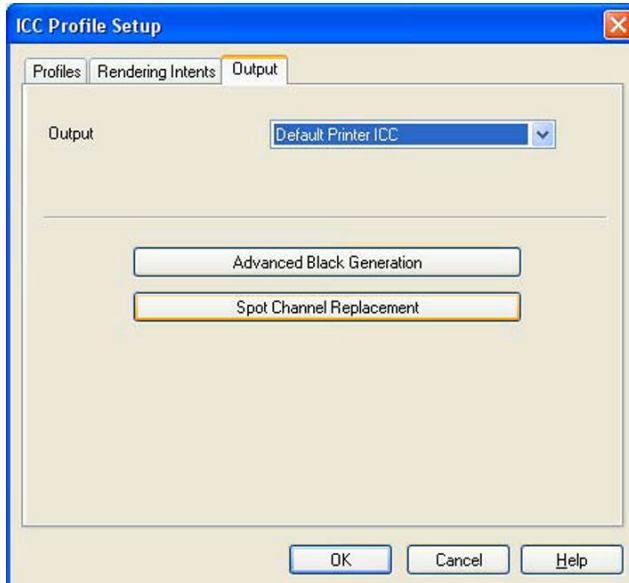

[88] Spot Channel Replacement

4. Enter the new name in PostScript Spot Color Name in Spot 1 space.

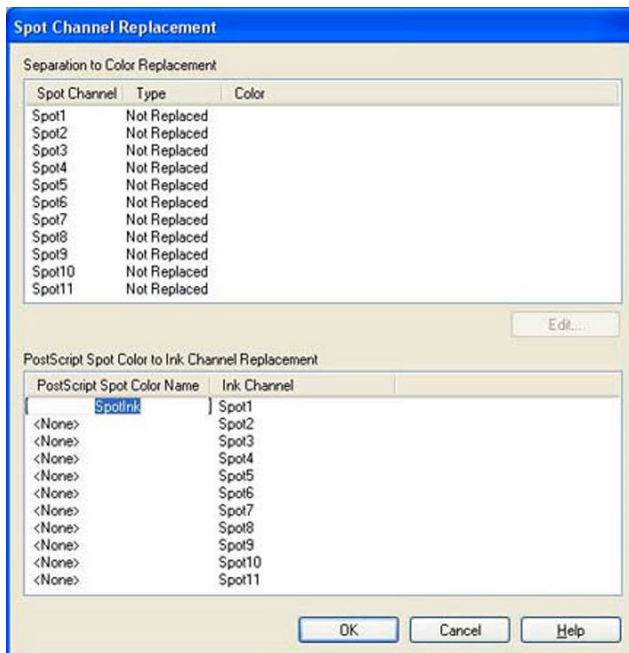

5. Click OK to save your settings.

White Ink QuickStart

Introduction

This section shows you how to print a simple job with a white flood fill. Océ Arizona Quality-Layered print mode is used to print white ink applications such as under-printing for non-white media, over-printing for backlit applications viewed 2nd surface or as middle layer for a day-night application. The following section provides more detail about the various options available when printing with white ink.

Purpose

This exercise will help you get familiar with some of the basic concepts involved when you print images with white ink.

Before you begin

Obtain and import an ONYX media profile (media model) that is set to Quality-Layered print mode.



NOTE

Sample Media profiles for white ink are available for download from the DGS website: : <https://dgs.oce.com>.

How to Print a Simple Job Using White Ink

Procedure

1. Open an image of your choice with an ONYX media profile that uses Quality-Layered print mode.
2. Take the printer offline in ONYX RIP-Queue so the job will not be automatically sent to the printer.
3. Process/rip the job.
4. Define one or two of the data layers as a white flood layer.

To define a white flood layer, modify the printer settings of a processed job in RIP Queue - right click the job, edit printer settings, select Quality-Layered for the Printer Print mode, then select Define Layers.

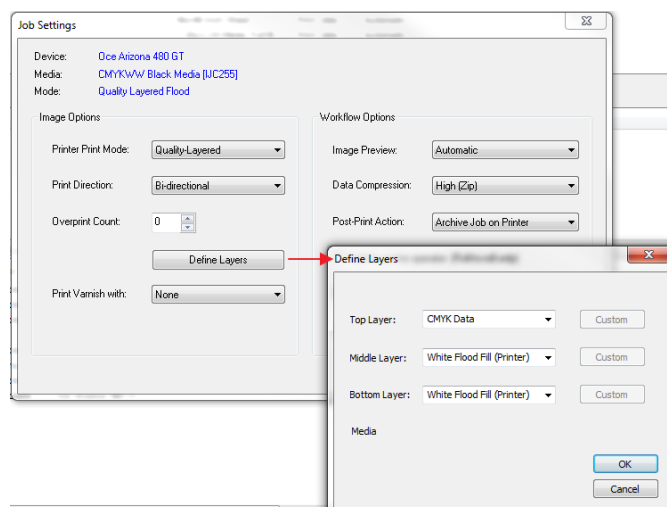

If you want to print first surface (e.g. opaque media) the bottom and middle layers can be configured to be white flood layers and the top layer to be a CMYK data layer. If you want to print

second surface (e.g., transparent media viewed from side that does not have ink on it), then the bottom layer should be a CMYK data layer and the middle and top layers white flood layers.

- 5.** Put the printer back online in ONYX RIP-Queue and send the job to the printer.
- 6.** Print the job.

How to Print White Ink Jobs

Introduction

White Ink can be printed in two ways:

- A. Multiple Layers - Using a Quality-Layered print mode
- B. Single Layer - Using any non Quality-Layered print mode that has been made with a CMYKSS ink configuration with spot colors defined.

A. Printing a Multiple Layer Print Job with White Ink

Océ Arizona Quality-Layered print mode is used to print white ink applications such as under-printing for non-white media, over-printing for backlit applications viewed 2nd surface or as middle layer for a day-night application

Print modes other than Quality-Layered mode can also be used to print only white ink, or area's of white ink in an image as long as the ONYX media profile (media model) has been made with a CMYKSS ink configuration with spot colors defined.



NOTE

When you print white ink using a print mode other than Quality-Layered, we recommend that you don't print white ink in the same area of an image as CMYK inks. The white ink does not mix well with the other ink colors.

For Quality-Layered print mode jobs:

1. Create spot data in a design application.



NOTE

Not required if only printing white ink using a printer generated white flood or using the ONYX Spot Layer Tool to create spot data (step 3).

2. Open the job in ONYX workflow software using an ONYX media profile that has been made using the Quality-Layered print mode. (See section "White Ink and Varnish ONYX Media Profiles").
3. Create underlay or overlay spot data using the ONYX Spot Layer Tool.



NOTE

Not required if only printing white ink using a printer generated white flood or using spot data created in a design application (step 1).

4. If the desired layer definitions have not been predefined in the ONYX media profile or Quickset, select "Hold for Operator" prior to submitting the job to be printed (step 5), so that the job will not automatically be sent to the printer.

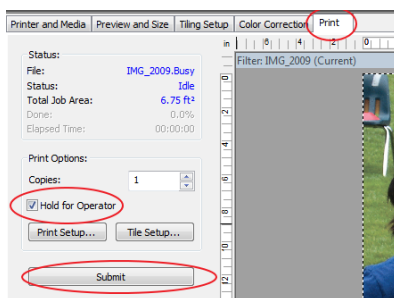

[89] Hold for Operator

5. Submit the print job (i.e., process/rip the job).
6. Define or verify the layer definitions prior to sending the job to the printer.



NOTE

Optional - not required if the layer definitions were correctly specified in the ONYX profile or quickset.

7. Send the job to the printer and then print it.



NOTE

To preview the layer order of the job on the printer, click Layers for the job in the printer software UI.

Configuring Quality-Layered Print Mode To Print White Ink

The Quality-Layered print mode can be used to print three, two, or one layer of image data or printer generated flood data. All layers are independent of each other.

Where to Define Layers

Quality-Layered layers are defined in ONYX media - mode options, but may be optionally overridden within a Quick Set - Media Options, and optionally overridden on a per job basis by modifying the printer settings of a processed job in RIP Queue - right click the job and edit print settings. Editing the print settings for a job displays the following dialog:

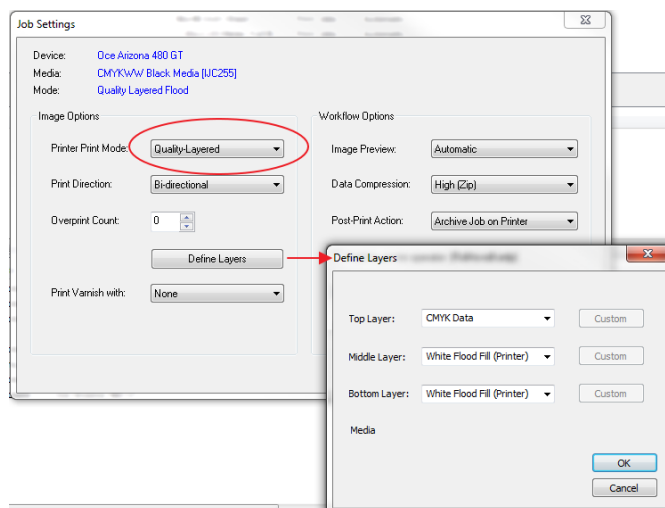

Layer Definitions

The layers are identified as bottom, middle and top. The bottom layer is printed first (if it is not empty) and the top layer is printed last (if it is not empty).

Use the layer indicated to print the following white ink applications:

Under-printing white ink for non-white media

- Top - CMYK
- Middle - W (spot data or printer generated flood)
- Bottom - W (spot data or printer generated flood)

Over-printing white ink for backlit applications viewed 2nd surface

- Top - W (spot data or printer generated flood)
- Middle - CMYK (mirrored)
- Bottom - CMYK (mirrored)

Print white ink for middle layer for a day-night application viewed 2nd surface

- Top - CMYK (mirrored)

- Middle - W (spot data or printer generated flood)
- Bottom – CMYK (mirrored)

Each layer can be defined with one of the following choices:

CMYK Data - CMYK image data

White Spot Data – Print Spot 1 data with white ink

White Flood Fill – Printer will generate flood data for the extent of the image data using the largest ink drop level

Custom - Custom ink color to data mapping and advanced options

Empty

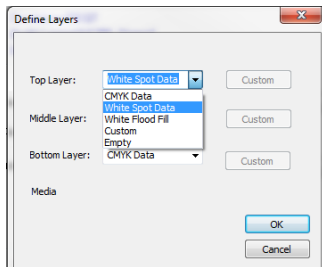

Custom Layer Definition

The "Custom" layer definition allows customer ink color to data mapping and advanced options for the selecting the printer flood level or mirroring the data.

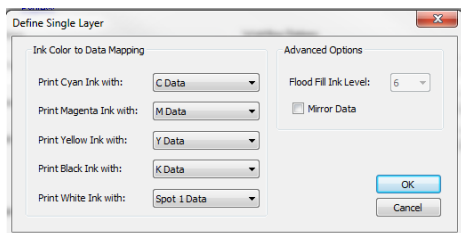

There are five color channels: C,M,Y,K and W, and six data planes: C,M,Y,K,Spot 1, and Spot 2 data.

Each color channel can be configured to print: nothing, any one of the six data planes, or have the printer generate flood data with a chosen drop level.

Example 1: White ink to be printed Spot 2 data

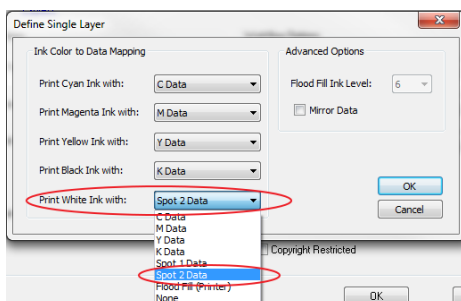

Example 2: White ink to be printed with printer generated drop level 4 (24 pl) data

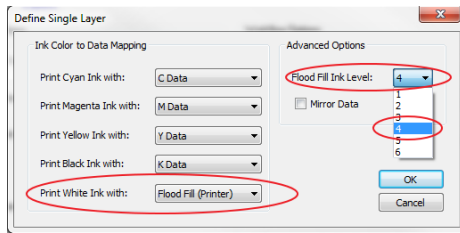

B. Printing a Single Layer Print Job with White Ink

For print jobs that do not use Quality-Layered mode:



NOTE

When you print white ink with print modes other than Quality-Layered, it is not recommended to print white ink in the same area of an image as CMYK inks. The white ink does not mix well with the other ink colors.

1. Create spot data in a design application. (See section "How to Create Spot Data")
2. Open the job in ONYX workflow software using any print mode other than Quality-Layered with an ONYX media profile that supports printing of white spot ink. (See section "White Ink and Varnish Media Profiles")
3. Submit the print job (i.e., process/rip the job).
4. Send the job to the printer and then print it.

Varnish QuickStart

Introduction

This section shows you how to print a simple job with a varnish Printer Flood Fill. The following section provides more detail about printing with varnish.

Purpose

This exercise will help you get familiar with some of the basic concepts involved when you print images with varnish.

Printing varnish requires an ONYX media profile (media model) that was made with a CMYKSS ink configuration with spot colors defined. All print modes are supported except the High Definition print mode.

Before you begin

Import an ONYX media profile that was made using a CMYKSS ink configuration with 2 spots defined.

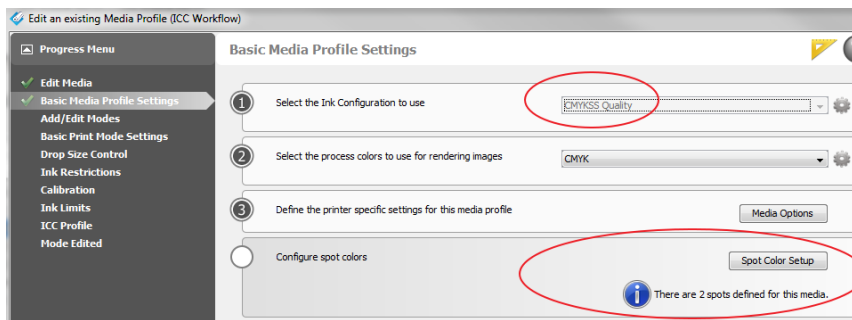

NOTE

Sample Media models for varnish are available for download from the Customer Support section of our website: <https://dgs.oce.com>. These media models are documented later in this chapter (see How to Use Media Models to Print with White Ink or Varnish).

How to Print a Simple Job Using Varnish

Procedure

1. Open an image of your choice using an ONYX media profile that supports spot data (CMYKSS ink configuration with spot colors).
2. Take the printer offline in ONYX RIP-Queue so the job will not be automatically sent to the printer.
3. Process/rip the job.
4. Define a printer flood coat.
To set up a varnish printer flood, modify the printer settings of a processed job in RIP Queue - right click the job, edit printer settings, then select Print Varnish With: Flood Coat (Printer).

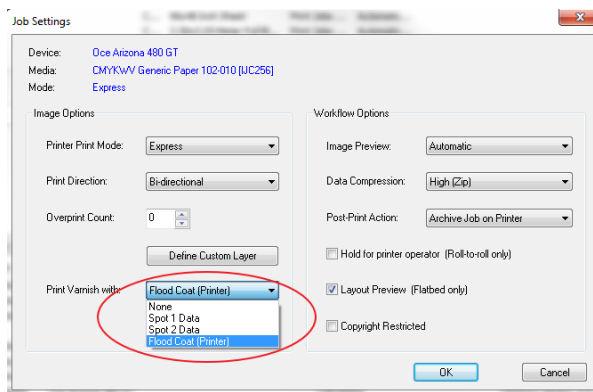

5. Put the printer back online in ONYX RIP-Queue and send the job to the printer.
6. Print the job.

How to Print Varnish Jobs

Printing varnish requires an ONYX media profile (media model) that was made with a CMYKSS ink configuration with spot colors defined. All print modes are supported except the High Definition print mode.

Varnish can be printed using either Spot 1 or Spot 2 data, or a printer generated flood coat. Varnish is always overprinted on top of printed image, and there no options to control the amount of varnish or lamp levels used to cure the varnish.

To print varnish:

1. Create spot data in a design application. (See section “Spot Data Creation”)



NOTE

Not required if printing varnish using a printer generated flood coat or using the ONYX Spot Layer Tool to create spot data (step 3).

2. Open the job in ONYX workflow software using an ONYX media profile that supports spot data and does not use the High Definition print mode. (See section “White Ink and Varnish Media Profiles”).



NOTE

All print modes except High Definition (HD) can be used when printing varnish.

Tip: To print varnish on top of a HD print mode image, use a composite job batch and print the first job in HD print mode, and the second job using a different print mode to print only the varnish data.

3. Create spot data using the ONYX Spot Layer Tool (See section “How to Create Spot Data”).



NOTE

Not required if printing varnish using a printer generated white flood or using spot data created in a design application (step 1).

4. The options for printing varnish are: None, Spot 1 Data, Spot 2 Data, or Flood Coat. If the desired option for printing varnish has not been predefined in the ONYX media profile or Quickset select “Hold for Operator” prior to submitting the job to be printed (step 5), so the job will not automatically be sent to the printer.
5. Submit the print job (i.e. process/rip the job).
6. Verify or select how varnish is to be printed. Right click the job in the ONYX Rip-Queue, edit Print Settings and the following Jobs Settings dialog will appear:

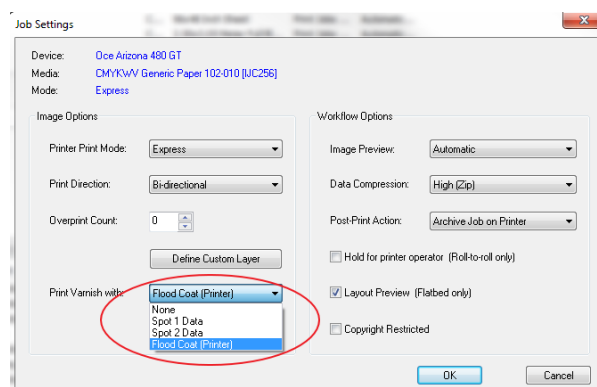



NOTE

Optional - not required if the method for printing varnish was correctly specified in the ONYX media profile or quickset.

7. Send the job to the printer and print it.

How to Get Good Results With Varnish

Introduction

The application of varnish to a print produces some spectacular, and at times, surprising results depending on the combination of design and media. To achieve a smooth high gloss, varnish must be applied in heavy coats. To achieve good results with varnish, consider the following principles and tools:

- **Maintain a Clean Environment**
- **Keep the Printer Clean**
- **Prepare the Media Surface**
- **Consider Varnish in the Job Design**



NOTE

Varnish does not require any special handling but, as with all inks, regular printhead maintenance is important.

Maintain a Clean Environment

All inkjet printers are prone to image quality / jetting reliability issues when there is airborne dust or other debris that can interfere with the jetting of ink from the printheads. The air quality within the room is extremely important to the achievement of printed varnish images with minimal dust contamination. It is also beneficial for maintaining the overall image quality and printhead jetting reliability.

In the printer operating environment the amount of airborne particles can influence the final varnish finish. Since the systems that condition and circulate the air can also circulate dust and particles, keeping the printer clean enough to produce good gloss varnish finish may require extra cleaning. If you use the Varnish option frequently, we recommend that you take steps to minimize contaminants by isolating the printer from dusty conditions.

Some tips for minimizing airborne dust and debris contamination:

- Install a good ventilation system and diligently keep air filters clean.
- Avoid dusty areas – printer should not be located near routers, sanders, trimmers or other machinery that generate airborne dust and debris.
- Do not install the printer on carpet or untreated concrete floor or other surfaces that can be a source of dust.
- Avoid placing the printer near air vents.
- Frequently wet-mop the room floor.

Keep the Printer Clean

Since the printer has moving parts (e.g., fans, carriage, gantry etc.) it is important to keep these parts clean and dust free to minimize the risk of circulating airborne dust and debris and depositing it on the media. Follow these tips for keeping the printer clean:

- Keep the fan filters clean and replace as needed.
- Wipe the bottom of the carriage clean with a lint free cloth.
- Wipe (with a swab) the cut holes in the carriage pan around the printheads.
- Wipe the external parts of the printer with a damp lint-free cloth: the table, gantry, carriage etc..

Prepare the Media Surface

Varnish can be successfully applied to most media. However, on some un-coated high-absorbent media, the varnish can be "lost" to the surface and it will be hard to tell that anything was applied.

If there are issues applying varnish to particular media, try printing on a suitable alternative media.

With its translucent property, varnish can increase or shift the apparent density of the image or media, so for instance it can make a gray slate darker in the areas with varnish.

It is important to clean media before printing and to remove any dust or debris from the media surface. Also, to eliminate any static charge on the media prior to printing, use the optional printer Static Suppression Option (ionizer bar) to eliminate static.

Some media can be purchased with a top protective sheet that is removed prior to printing. However, the act of removing the protective sheet can induce a static charge and attract airborne dust to the media surface. Based on our experience, there is little benefit in trying to clean the media after printing the image data and prior to printing the varnish.

The surface of the media must be free from dust and dirt particles. With the media loaded on the table, we recommend that you gently and completely wipe the surface with a lint-free cloth or a Tack Cloth.

There are various methods employed in print shops to clean media prior to printing and these include:

- Tack cloth and Cleaning wands (floor cleaning style);
- Mix of 99.6% or higher pure isopropyl alcohol and distilled water.

Tack Cloths are a highly effective tool for trapping and removing dust and dirt particles from most surfaces. They can be purchased at various stores that offer paint and supplies. It is best to attach a Tack Cloth to a flat object and let it lightly rest on the media while it is wiped.

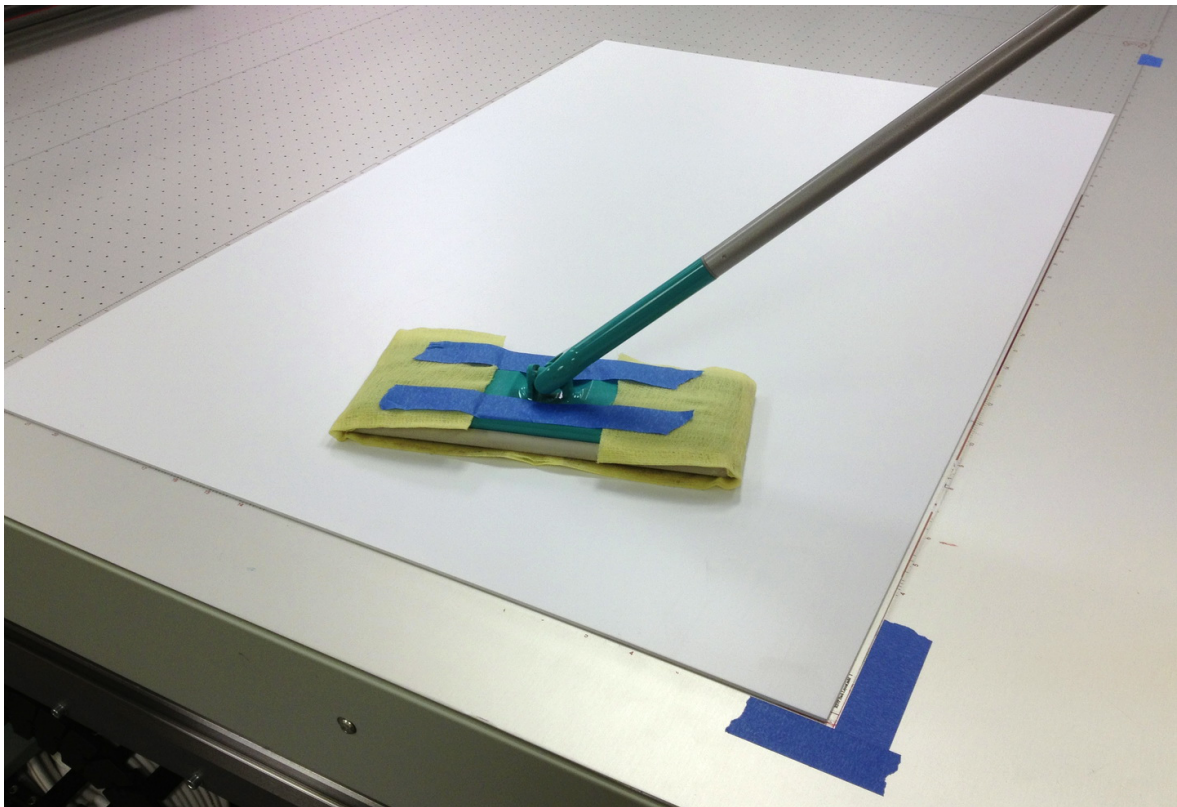

[90] Tack cloth and cleaning wand

Electrostatic Cleaning Devices can be used with a Tack Cloth attached to wipe the surface and will reduce static charges that attract more dust. The long handle allows access to the media across the entire printer table. Lint Free Cloths can also be used.



NOTE

Note: we recommend that you fasten the tack cloth to the cleaning wand, as shown above. It is easier to apply even pressure with this method. When you use the tack cloth by hand it tends to leave an uneven swath path on the media you are cleaning. Also, it is important to clean the whole area of the table as the carriage will pass over more of the entire table than the area where the media is located.

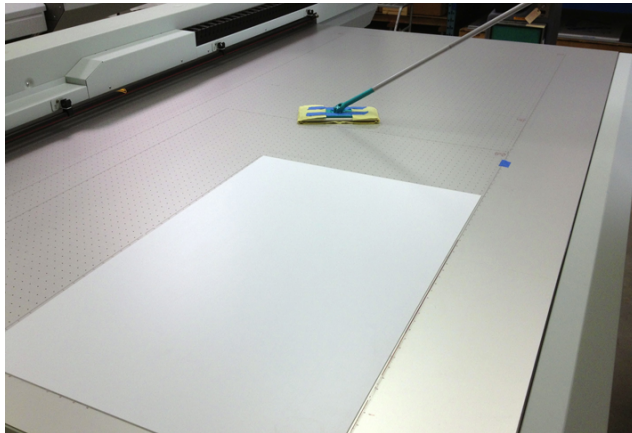

[91] Clean the whole area of the table

Consider Varnish in the Job Design

Printing varnish creates a high value-added special effect. However, since this is an additional process after printing image data, it also decreases productivity.

Due to the low productivity of printing large areas of varnish, it is best to concentrate the use of this feature on spot decoration.

Fortunately, the Arizona printer "blank space" skipping feature skips over areas in the print that do not contain varnish, and greatly improves the net productivity of spot applications.

Some design tips:

- Avoid large areas of varnish to lessen the chance that dust and debris contamination may be noticeable;
- Target small elements within the design and use varnish to draw attention specifically to them, e.g., glossy lips, shining eyes, water droplets, brilliant lights etc.;
- Avoid coating areas where a bright white is required, as the varnish (clear ink) has a slight yellow tone.

Preparing To Print Varnish

Follow these simple points to produce good results with the Varnish option:

- Clean the surface of the media before each print. If you gloss coat a rough stock it may be difficult to "fill in the surface" and achieve a smooth high gloss finish.
- Ensure the printer is clean. Frequently clean the underside of the carriage to avoid dust being deposited on the print.
- Keep the UV Lamp Filters clean.
- Verify the printer will use the Static Suppression Option (if installed) when printing static-sensitive media.

- During printing, avoid actions that introduce airborne dust and debris that can end up on the media being printed.
- For a smooth high gloss use a smooth coated media as it will allow the varnish to flow well.



NOTE

If you gloss-coat a rough media it may be difficult to "fill in the surface" and achieve a smooth high gloss finish.

Chapter 10

Ink System Management

Arizona Printer Ink

Introduction

Your Océ Arizona printer uses UV-curable ink. Daily and weekly maintenance activities are necessary to maintain optimum printing performance. Your printer can support different Océ UV-curable ink types. If you want to change from one ink type to another we recommend that you consult with an Application Specialist. There are many variables, such as media, that determine the suitability of an ink to your working methods and output means. An application specialist will help you make the best decisions.

Managing Your UV-curable Ink

Your printer is optimized for UV-curable ink supplied by Océ. The ink is supplied in a collapsible bag. To install ink on the printer, the bag is inverted and a quick connect coupler is engaged. This opens up the flow path for the ink. The bags contain tags that identify them to the printer when they are loaded. This allows the printer to ensure that the correct ink is loaded.

Ink bags have several benefits over bottles or cartridges:

Self-collapsing bags make it easy to see how much ink remains in each bag.

- Virtually all the ink is successfully extracted from the bag by the printer, reducing the otherwise costly waste of usable ink.
- Ink changes are performed without mess or spills, keeping the environment around the printer clean.
- Ink changes can be performed during printing - this prevents wasted prints and lost time.

Only qualified inks can be used. If a bag of ink with an invalid serial number, expired use-by date, incorrect color placement in the ink bay, or if an expired tag is connected to the printer, then the operator is alerted and an error message is displayed.

Access to MSDS Ink Information

MSDS (Material Safety Data Sheets) for each color of ink and the UV Flush are available from the corporate Océ Global E-Marketing (GEM) website. For the latest MSDS and PSDS, visit: <http://global.oce.com/support/>. Read and periodically review this safety information to ensure optimal safe handling procedures and proper emergency responses are followed when using UV inks and flush.



CAUTION

Wear eye protection and nitrile gloves when handling or cleaning ink. Also, when working around ink protect your clothing and any exposed areas of skin.



IMPORTANT

Do not install inks that are not certified by Océ for use in this printer, as this may result in poor quality prints, uncured ink in the finished prints and permanent damage to the ink pumps, filters, ink lines or printheads.

Ink Bags in the Ink Bay



Ink Filters

The printheads in your printer are protected from contaminants in the ink by means of ink filters. These are easily accessed and can be replaced by the operator when they become blocked with debris (see the Maintenance section "Change Ink Filters").



NOTE

A loss of pigment when printing a nozzle check or long ink fill times indicates that a filter is clogged and must be replaced.

How to Store and Handle UV Ink

To ensure print quality and to extend the life of printheads in your printer, UV inks must be properly handled and stored correctly.

- Inks must be stored within a temperature range of 5 - 30°C (41 - 86°F). Exposure to extreme temperatures will reduce the expected life of the ink.
- Do not use ink that is past the expiry date.
- Store in cool, dry place and keep away from heat and direct sunlight.

White Ink

If your printer has the white ink option and white is not printed on a regular basis, pigment settling can occur in the white ink printheads. During periods of white ink inactivity the printer will automatically try to maintain the white ink channel using the following methods:

- ink recirculating
- spitting

Additional efforts may be required to recover nozzle performance for the white ink printheads.

Change Ink Bags

Introduction

The ink is supplied in collapsible bags. An ink bag can be replaced at any time. An ink bag can be changed during a print job. It is not necessary to stop the printer.

When to do

Ink bags should be replaced if:

- The printer displays an "Error: ink fill timed out" message.
- The operator sees that the bag is empty.
- An ink bag is nearly empty and the operator wants to leave the printer unattended during a long print and does not want the ink to run out. The nearly empty bag can be reconnected and used up later when the operator is present.



CAUTION

Use appropriate safety equipment - nitrile gloves and eye protectors. Take precautions to avoid ink on your skin or in your eyes. Be sure to read the section on Safety Guidelines for Ink Materials before handling UV inks. Also, read the SDS sheets available from the Océ Downloads website for more information on ink safety and handling.

Remove the Quick-Release Coupler



Procedure

1. Open the clear plastic door on the Ink Station.
2. Identify the ink bag to be replaced.
3. Press the quick-release coupler button at the bottom corner of the ink bag.
4. Unhook the bag from the top of the ink station.
5. Replace with a new ink bag of the same color.
6. Push the quick-release coupler at the bottom corner of the new bag into place.



NOTE

If you place a bag in the wrong ink station (for example, yellow ink in the black ink station) the display will show an error message and the printer will not print until the correct bag is installed.

Chapter 11

Troubleshooting

Troubleshooting Overview

Introduction

This section covers general problems that may occur with the printer. Malfunctions that trigger system error messages can be caused by human error, a system malfunction, an interface cable malfunction, mechanical printer malfunction and/or printer firmware failure.

Basic Troubleshooting

Troubleshooting helps you locate the source of errors and fix common problems that can arise during printing.

Troubleshooting Areas:

- Printer behavior
- Print quality
- Data transfer

Printer Errors

Some errors are problems that interfere with the print process but do not shut down the printer completely. Typically, these errors are problems that prevent starting a printing job or that interrupt the current print. You should be able to fix these errors without a service call. Other errors stop the printer and prevent operation until the error is resolved. The printer interface informs you as to what is wrong by displaying an error message on the LCD display. If the error message has an obvious solution, apply the appropriate remedy. Otherwise note the exact error message and associated error number and what the printer was doing before the error, then place a service call.

If Problems Persist

If problems persist, perform the following actions as appropriate for the situation:

- Check for media that is buckling or sitting too high on the table.
- If you just changed ink in the printer, review the procedures in this manual and check for successful installation.
- Try printing a test print.
- If the printer is not receiving print jobs, check the network cable connection.

Call for Service

Try to eliminate simple problems before you call your service representative. However, it is important to know when to call for service. Without training, servicing the printer yourself may cause further damage. When you have determined that a service call is required, call as soon as possible. Have the following information ready:

- Printer serial number — located near the AC power plug.
- Error message displayed on the control panel, if any.
- The exact circumstances when the error occurred, such as during printing, or maintenance.
- Note any unusual phenomena, such as peculiar printing, noises, and smells associated with the failure.

Chapter 12

Printer Maintenance

Maintenance Guidelines

Introduction

This section describes what is required for proper printer maintenance.

Maintenance Equipment

- Foam Tipped Swab (3010118211)
- Flush (3010106646 Flush UV 1 Liter)
- Bottle-HDPE 125ml for flush (3010105433)
- 99.9% Isopropyl alcohol (IPA)
- Cloth-Poly Wipe 10cm x 10cm (lint-free)
- Dust cloths



CAUTION

When cleaning areas of the printer that have uncured ink contamination, the following PPE is recommended - nitrile gloves (Ansell Touch N Tuff gloves, 92-600 for smooth or 92-605 for textured), a lab coat and safety glasses with side shields. It is recommended that gloves are used for one time only and should be removed and replaced with new gloves if contaminated with inks or damaged. Chemicals in UV inks can penetrate nitrile gloves in less than 10 minutes. UV-curable inks can contain sensitizing chemicals which can lead to sensitization upon prolonged or repeated exposure to skin. Océ recommends that contaminated gloves are removed and replaced with new gloves.

Operator Maintenance Schedule

Maintenance Frequency

Procedure	Frequency
Printhead Maintenance (manual or AMS, if that option is installed)	Daily and as needed
Clean all horizontal surfaces	Daily
Clean AMS (if installed)	Daily
Clean Ink Spit Tray	Daily
Clean Carriage Underside	Daily
Maintain White Ink	Daily
Clean (Swab) Printheads	Weekly (daily with IJC258 ink)
Replace UV Lamp Filter	Every two weeks
Remove Ink from Table	As needed
Empty the Waste Trays	Weekly or as needed
Check Coolant	Monthly (fill as needed)
Clean Gantry Rails	Monthly or as needed
Check UV lamp windows	Monthly (clean if necessary)
Change Ink Filters	After 50 liters of ink, or if pigment looks weak
Change both UV Lamp bulbs	After 500 hours to prevent insufficient curing
Change Coolant	Yearly (requires a service call)

Maintenance Procedures

Check Printhead Nozzle Performance

It is important that nozzle performance is evaluated to determine if the printer is ready for production. To evaluate the nozzle jetting performance of each printhead the nozzle check print must be printed.

The nozzle check print shows the performance of each individual nozzle in each color channel. This information is critical in determining how to proceed in recovering nozzles with Printhead Maintenance or the optional (AMS).

Procedure

1. Place a piece of Océ I/O paper on the printer table (or use the RMO, if available).



NOTE

The dimensions of the nozzle check print are 617.3 x 73.7 mm (24.3 x 2.9 inches).

2. Select the Nozzle Check icon at the right end of the Command Toolbar to place the nozzle check into the Active Print Job list (you can also add a Nozzle Check to the active print list when you select it from the Special Prints module).
3. Confirm media thickness.
4. Activate the table vacuum.
5. Push the printer **Start** button to begin the print.
6. Evaluate the nozzle check. In the Nozzle Check print example shown in the figure below, the Magenta printhead 6 has nozzles that are not firing properly in both Package A and B. It also shows a new nozzle print after the printheads were cleaned.

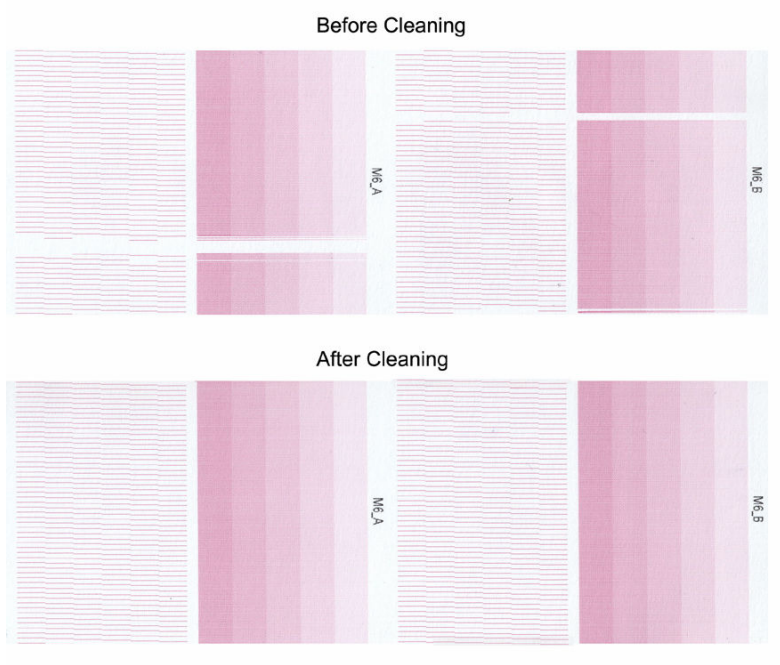

NOTE

This is an extreme example to illustrate the problem. In most cases you will likely see only a small number of nozzles out or misdirected as shown.

7. Once you have identified the particular printhead(s) that has nozzles out as indicated by the nozzle check print, you can perform the Manual or Automatic Printhead Maintenance procedures described in the next section to correct the nozzle dropouts.

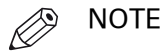

Do Printhead Maintenance or (optional) AMS on the required color channels if:

- more than 2 nozzles outs exist in a single printhead
- 2 or more adjacent nozzle outs exist in a single printhead
- more than 4 nozzle outs exist in a single color

Manual Printhead Maintenance

Introduction

Manual Maintenance of printheads involves purging the printheads and then using a suction device to remove a small amount of ink and any debris that is in the nozzles. The Maintenance Station is located below the carriage. The station is covered by a sliding drawer that has open slots that allow waste ink to collect in the waste tray. When you perform manual printhead maintenance, any excess ink and associated debris are removed from the nozzles.



IMPORTANT

The nozzle plate on the printhead has a non-wetting coating - contact with this surface may affect the performance of the printhead. Do not wipe the nozzle plate with anything other than the suction-head (or the supplied swabs when following the swab procedure) as this can damage the nozzles and impair performance.

When to do

Perform Printhead Maintenance at the start of the day (after the printer has warmed up) or when necessary (misfiring nozzles, banding in image, etc).



NOTE

Tip: To help locate nozzles that need recovering remove the nozzle check print from the vacuum table and place it on the floor under the carriage in the maintenance area. Make sure it is in the correct orientation so the colors are aligned. The print represents a projection of the jetting performance of each printhead. This makes it easier to trace a nozzle or group of nozzle outs back to the area on the actual printhead nozzle plate that requires swabbing.

Printhead Maintenance



CAUTION

The underside of the UV lamps may be hot, avoid touching them.



IMPORTANT

Do NOT press up too hard on the printhead while you swipe it with the suction-head as this can dislodge the printhead and require a service call to re-seat it.

Maintenance Station Switches:

There are three switches inside of the maintenance station . They can be operated in any order. For example, you can press the middle switch to raise the carriage to remove debris from the underside of the carriage even when a purge isn't required.

1. Switch 1 to purge ink (the preferred way is to use the UI as in step 3 below)
2. Switch 2 to raise carriage
3. Switch 3 to activate suction pump

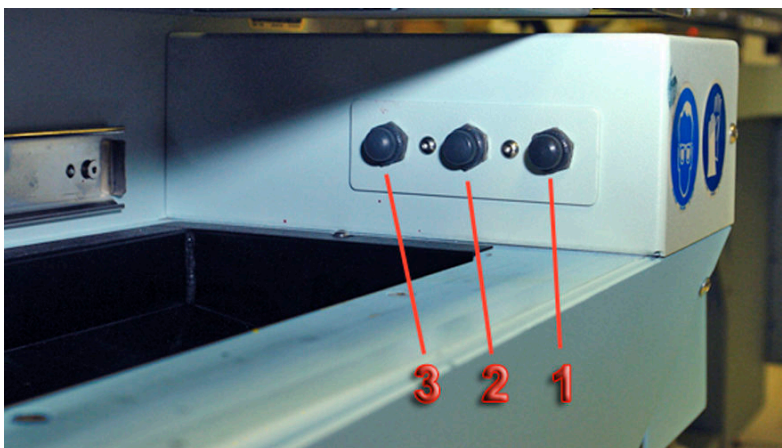

[92] Maintenance Station Switches

Procedure

1. Verify that the ink temperature is at least 40° Centigrade (104° Fahrenheit) before you begin printhead maintenance.
2. Slide the drawer out from under the carriage to reveal the maintenance station.
3. Select the Maintenance tab and then the Manual maintenance icon in the top right corner to open the Manual Maintenance Assistant screen where you can select the ink channels that will be purged.



4. Select the specific ink channels to purge by clicking on "Purge". In the example below all ink channels are selected.

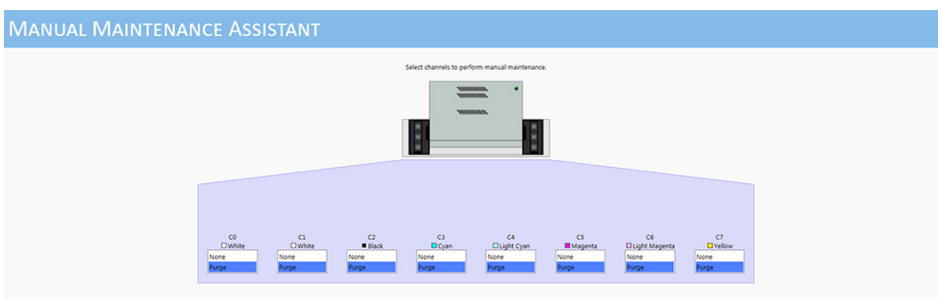

5. Press Purge button (1) to begin a standard ink purge of the selected channels. The carriage will lower to its purge height.
To achieve a Long purge, press the Purge button for more than 5 seconds. Long purges may be necessary if an acceptable result is not achieved with a standard purge.
6. Press the middle button (2) to raise the carriage to its maximum height and watch the ink as it falls from the heads. Wait until most of the ink stops dripping (but don't wait too long or the ink and any debris in it will get sucked back into the printhead).

**IMPORTANT**

Be careful not to snag the coiled suction-head hose when removing the suction-head from the holder.

7. Press the Suction button (3) to turn on the suction pump. Pick up the suction-head from the tray at the left end of the maintenance station. Wipe the suction-head with a new, clean lint-free wipe after cleaning each color.

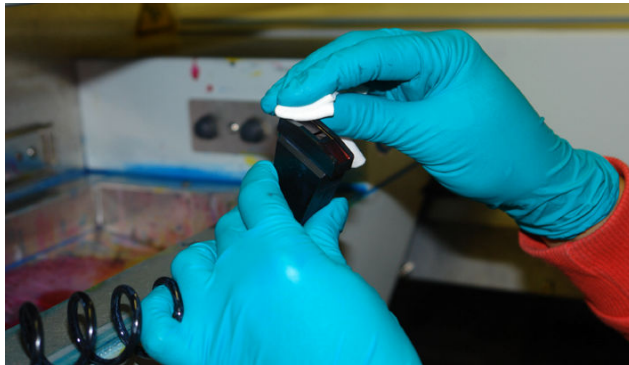

[93] Clean Suction-Head

**IMPORTANT**

In the next step, start with the left printhead and work to the right as this limits the possibility that drops of ink will fall onto the coiled hose. Also, do not push up too hard on the printhead as you may dislodge it and this will require a service call to fix.

8. Slide the suction-head slowly along the entire length of each printhead at a speed of approximately 8mm per second (8 seconds per printhead). The suction-head slides on stainless steel strips on the printhead. It may be necessary to repeat this step in the following cases:
 - a) Visual inspection of the printhead shows signs of ink remaining on the nozzle plate;
 - b) Suction-head was not kept level during travel across the nozzle plate;
 - c) Suction-head was pulled too quickly or unevenly across the nozzle plate.

**IMPORTANT**

Move the suction-head slowly so that you don't "plow" excess ink to the front and sides of the printhead and suction-head. If you move too fast, ink is pushed onto the upper edge of the printhead opening in the pan, where it is difficult to see and causes problems.



[94] Swipe Printhead

9. Wipe the suction-head on a clean piece of new lint-free wipe before proceeding to the next printhead.



IMPORTANT

During maintenance, be careful not to touch the nozzles or the nozzle plate as this can damage the printhead.

10. Use a dry swab to pick up any excess ink from around the edge of the printhead opening in the pan (see the white line with arrows in the image below). Take special care to remove any excess ink, flush or alcohol on the metal plate between the pan and the printhead (see the area covered by the two ellipses in the picture below). A single swab can be used for each color channel or use it until the swab becomes saturated with ink.

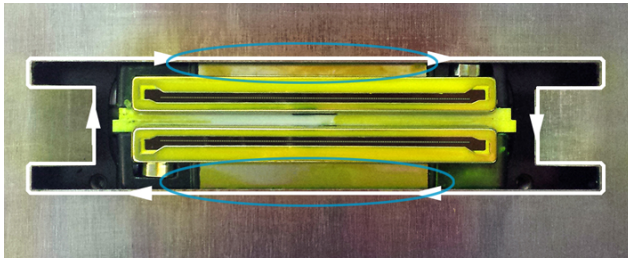

11. Slide the maintenance station drawer back to its closed position. The carriage will move back to its previous print-ready height.



IMPORTANT

Close the drawer gently to avoid disturbing the ink in the printheads. A hard bump can temporarily create nozzles out.

12. Print a Nozzle Check to evaluate print quality.



NOTE

If the Nozzle Check print shows that a printhead still has a few nozzles out you can slide the suction-head over that printhead again. Then print another Nozzle Check if there are still nozzles out.

Recover Nozzles by (Optional) AMS

Introduction

Automatic Printhead Maintenance (AMS) is used to recover the jetting performance of the printhead nozzles. The AMS is located on the opposite side of the gantry from the Manual maintenance station. The AMS is an option that must be ordered and installed on the printer by a service representative.

When to do

Either Automatic or Manual Printhead Maintenance must be performed at least daily, and more often if required.

Before you begin

Ink must be at least 40° Centigrade (104° Fahrenheit) before you perform printhead maintenance. The Job Control module displays the ink temperature. If the temperature is low, activate the ink heater by clicking the icon and then monitor the temperature display.

Procedure

1. Select the Maintenance tab and then the Automatic Maintenance icon in the top right corner to open the Automatic Maintenance Assistant screen where you can select the ink channels that will be purged.

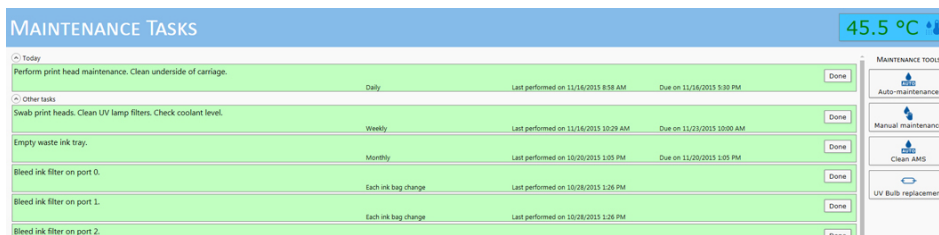

2. Select the ink channels to purge by clicking on either Standard or Long Purge. Use the Standard Purge for daily general maintenance. Use Long Purge after 3 Standard purge cycles have not produced an acceptable result.



3. After all ink channels are selected, click on Do Maintenance to begin the Automatic Maintenance.
4. When maintenance is finished click on the **Back** button to exit.

Cleaning the Automatic Maintenance System (AMS)

Introduction

If this option is installed, clean the AMS station daily.

Equipment

- Cloth-Poly Wipe 10cm x 10cm (lint-free)
- Isopropyl alcohol (IPA)
- Flush (3010106646 Flush UV 1 liter)

Procedure

1. Click on the Maintenance Tab and then select **Clean AMS** from the Maintenance Tools in the upper right side of the display.

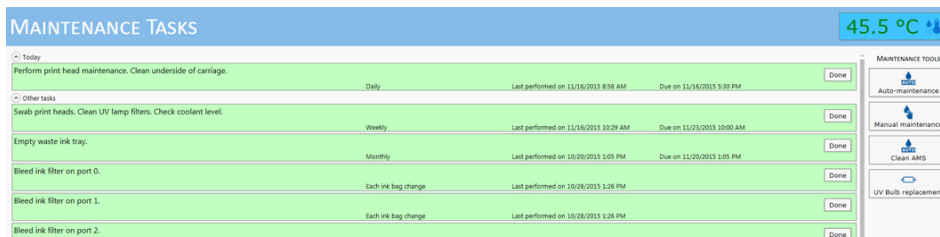

2. Remove the AMS cover plate by inserting an object such as the handle end of a swab into the small hole, slide the plate in the direction of the arrow on the cover, and then lift it off.

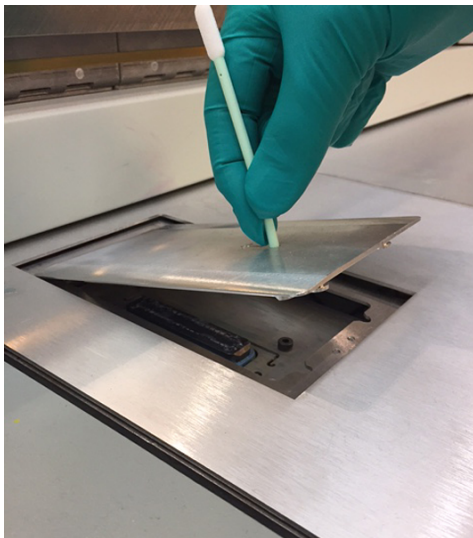

3. Turn the cover plate over and clean the underside using a lint-free cloth and isopropyl alcohol.

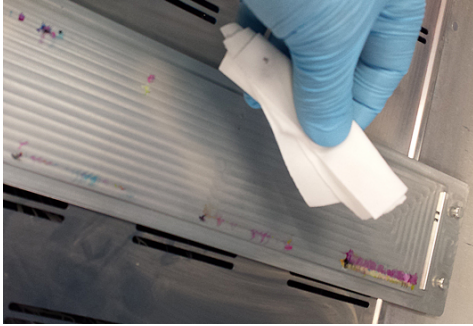

4. Pour some flush (not alcohol) on a clean swab.
5. From the AMS Cleaning Assistant screen, press **Start** to apply vacuum to the suction head for 30 seconds and, while the suction is active, gently draw the swab across the top of the suction head to remove any ink deposits.



IMPORTANT

It is extremely important that you NOT apply too much downward pressure on the suction head. If you press down more than 2mm (0.078in) then it will no longer perform printhead maintenance properly. Also, if a suction head is pressed down too far you will need to place a service call to fix it.

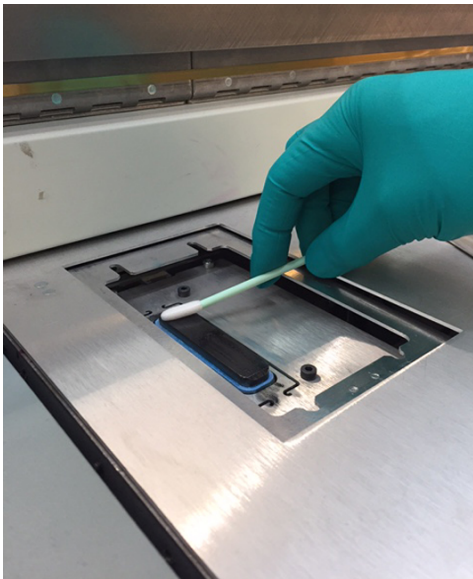

6. Replace the AMS cover.
7. Press **Finish Maintenance** and then **Back** on the AMS Cleaning Assistant screen to complete the cleaning cycle.

Clean Horizontal Surfaces

Introduction

To maintain optimal printing performance it is important to remove dust and debris from the following horizontal surfaces:

- Vacuum table
- Table extensions
- Gantry beds
- Carriage Cover
- RMO (if installed)

Equipment

- Dust cloths

Keep the Horizontal Surfaces Clean

A buildup of dust and debris on these surfaces can transfer to the underside of the carriage and printheads during printing. This can lead to performance issues such as nozzle outs or ink drips on the media.



Procedure

1. Clean all horizontal surfaces with a clean dust cloth.

Clean Carriage Underside

Introduction

The underside of the carriage must be cleaned daily. It may be necessary to clean it more frequently if any of the following conditions exist:

- media has a high level of static charge
- full bleed printing
- media thickness value is incorrect (carriage is too high)



CAUTION

For cleaning areas of the printer that have uncured ink contamination use the following safety equipment - nitrile gloves, a lab coat, and safety glasses with side shields to protect your eyes. If a nitrile glove is contaminated with ink, discard it within a few minutes. The penetrating chemicals have no pigment so they are not visible; therefore just because you don't see pigment on the glove or your skin doesn't mean that exposure has not occurred. Do not re-use gloves.

Equipment

- Poly Wipe cloths
- 99.9% Isopropyl alcohol



IMPORTANT

When you clean the carriage or printheads you may need a light to evaluate their condition. All light sources emit varying amounts of UV (ultraviolet) light. UV light cures the UV-based ink used in your printer. If the underside of the carriage is dark when examining the printheads or the carriage underside, consider the kind of light source you use for the inspection. LED flashlights and halogen lamps emit the most UV light, while tungsten and fluorescent produce the least. Most Smart phones with a light source use LED lights. Regardless of the light source used, always limit exposure of the printheads to the minimal time required (refer to Customer Application Bulletin 55, " Minimize Exposure to UV Light When Inspecting Printhead Nozzles" for more details).

Procedure

1. Slide the maintenance station drawer out from under the carriage.
2. Press the middle switch to raise the carriage to its maximum height.
3. Prepare a clean poly wipe cloth as shown here.

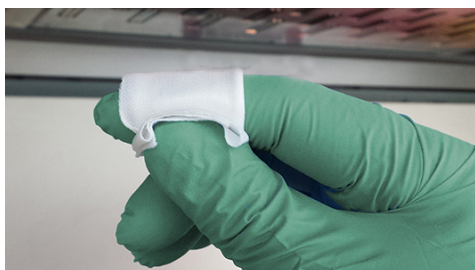

4. Dip the cloth in 99.9 % isopropyl alcohol.



IMPORTANT

In the next step, make sure that you do not touch the nozzles of the printheads. If you happen to touch one with the cloth, you must perform printhead maintenance. Note that contact with a printhead by any object other than the suction-head used for maintenance can cause damage to the nozzles and result in poor image quality or possibly require a printhead replacement.

5. Slide the cloth along the metal plate between the printheads to remove any ink that has accumulated.



[95] Cleaning the metal plate between printheads

6. Reposition the wipe so that a clean area is exposed.
7. Proceed to the next space between printheads and slide the clean area of cloth along the metal plate.
8. Repeat steps 3 to 6 until all ink is removed from the spaces between printheads. Use a new cloth wipe, if necessary.



NOTE

Check for ink accumulation on the underside at the end of each day. If ink is left to long it will dry and be very difficult to remove.

9. Slide the maintenance station drawer to the closed position (unless you are going to also perform manual printhead maintenance).

Maintain White Ink

Introduction

Printers with the White Ink Option require maintenance to ensure that the white printheads function properly. White ink is re-circulated in the system to limit any settling of the ink. For this to take place, **the printer must be left powered On at all times.**

A new white ink bag must be gently agitated before it is connected and then once a day thereafter. Daily maintenance and agitation is essential with the white ink option to keep the printheads clear and operating reliably.

When to do

Daily

- Perform printhead maintenance for white ink.
- Agitate the white ink bag.

Weekly

- Swab white printheads (use flush or 99.9% isopropyl alcohol).



NOTE

Extended Idle Time

Swab the White printheads with flush prior to letting the printer sit idle for an extended period of time. It has been demonstrated that leaving flush on the printhead nozzle face plates helps minimize the amount of maintenance required to recover nozzles after an idle period.

Note Attention Caution



IMPORTANT

Failure to properly maintain the white ink as described here can result in nozzle dropouts that degrade print quality.

Note Attention Caution



NOTE

You will see a message on the printer display that reminds you to agitate the white ink bag once a day.

Procedure

1. Open the clear plastic door of the Ink Bay.
2. Press the quick-release coupler button at the bottom corner of the white ink bag to release it.
3. Agitate the white ink bag according to the illustration on the bag.



NOTE

You must agitate the white ink bag for at least 5 seconds or the message will remain on the screen.

4. Replace the bag in the Ink Bay.

Clean the Printhead Nozzles

Introduction

Ink tends to accumulate on the bottom of the printhead nozzles and must be cleaned off on a regular basis.

When to do



IMPORTANT

To maintain print quality it is very important to swab the printheads once a week, or more frequently, if required. Failure to do this may result in plugged nozzles and poor image quality .

Foam Tipped Swabs (3010105434 Swab Foam Flex Tip)

Flush (3010106646 Flush UV 1Liter) or Isopropyl alcohol (99% pure)

Bottle-HDPE 125ml for flush (3010105433)

Before first use, proceed as follows: Label this bottle as "Flush", add the actual date of receipt of the bottle and the date of expiry (two years after receipt).



CAUTION

Discard the bottle if it shows any sign of wear or physical damage (cracking or leaking) or at expiry.



NOTE

To prevent contamination of the flush in the bottle, never re-dip a used swab in the flush. Flush must not be exposed to air for long periods. Always store flush in a sealed container. Flush has a recommended shelf life of one year. Discard it after one year has passed.

Note Attention Caution



IMPORTANT

Never "scrub" the printhead with a swab as this will drag debris into other nozzles. Note that the swab has a seam that can damage the printhead nozzles; use only the semi-curved foam sides of the swab.

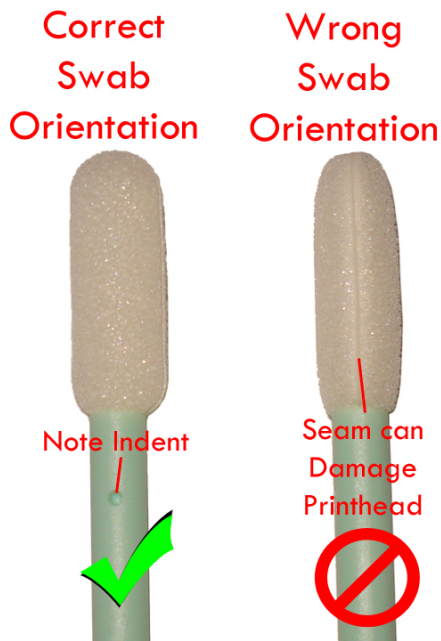

[96] Proper Swab Orientation

**NOTE**

Perform Printhead Maintenance **before** and **after** you swab the printheads. This ensures that the swabbing is more effective at cleaning the printheads as any debris in the ink is first sucked out of the nozzles and then any residual flush or alcohol left on the nozzles after maintenance is also sucked away.

- You may use either **isopropyl alcohol (99%)** or **flush** when swabbing the printheads. Flush is still the preferred cleaner for daily use, but alcohol can help when nozzles are difficult to recover.
- Do NOT perform a purge before you swab the printheads.

**NOTE**

***Tip:** To help locate nozzles that need recovering remove the nozzle check print from the vacuum table and place it on the floor under the carriage in the maintenance area. Make sure it is in the correct orientation so the colors are aligned. The print represents a projection of the jetting performance of each printhead. This makes it easier to trace a nozzle or group of nozzle outs back to the area on the actual printhead nozzle plate that requires swabbing.*

Procedure

1. Slide open the maintenance station drawer.
2. Dip a swab in a small container of flush or alcohol.

**IMPORTANT**

Swab one printhead at a time and use 1 swab per printhead. Do not re-dip a swab into the flush or alcohol. Also note that flush is a solvent and should not be splashed or sprayed around the printheads.

3. Position the swab at the far end of the printhead perpendicular to the nozzles and slowly draw it towards you (minimum of 8 seconds per printhead). Hold the swab at an angle to limit dragging

debris from one nozzle to the next. Do not let the seam in the foam touch the nozzles or the nozzle plate.



IMPORTANT

It is important to ensure the swab contacts only the nozzle face of the printhead. Also if there is any residual ink left on the carriage plate after swabbing, use a lint-free cloth soaked with alcohol to remove it.



4. Rotate the swab by 180 degrees and repeat the previous step.
5. Discard the swab and repeat Steps 2 to 4 for all the other printheads.
6. Perform Automatic Printhead Maintenance again. This ensures that no alcohol or flush is left in the nozzles.
7. Once finished, all residual flush and ink in the gaps around the head should be carefully wiped away with a clean swab.



NOTE

If swabbing does not recover a blocked nozzle, holding a flush or alcohol-soaked swab against the blocked nozzle on the printhead for at least ten seconds is an effective way of clearing the blockage.

8. Run a Nozzle Check print and verify that all nozzles are firing properly. Repeat swabbing procedure if necessary.

Replace UV Lamp Filter

Introduction

The printer has two UV lamp assemblies, one on each side of the carriage, to cure the UV ink during printing. The filters in these UV lamp assemblies have a limited lifetime and must be replaced by the operator to prolong the life of the bulb and maximize curing efficiency.

When to do

These filters should be changed every two weeks.

Before you begin

It is recommended to wear gloves when handling dirty lamp filters due to the possibility of partially cured ink deposits.

Failure to replace dirty filters will result in lamps operating at a higher temperature causing premature failures of internal components and lamp bulbs.

How to Replace the UV Lamp Filter

It is not necessary to shut the printer power off while replacing the UV lamp filters. However, make sure you turn the lamps off by de-selecting the lamp icon in the user interface before you start and allow a few minutes for the bulbs to cool down.



NOTE

Wear cotton or nitrile gloves when handling UV lamp filters. Avoid bare skin contact with UV lamp filters that are contaminated with partially cured ink.

Procedure

1. From the User Interface, deselect the lamp icon to turn the lamps off and allow to cool for 5 minutes.
2. Lift the magnetic lamp filter cover off of the lamp housing.



3. Lift the lamp filter off of the lamp assembly and set aside.

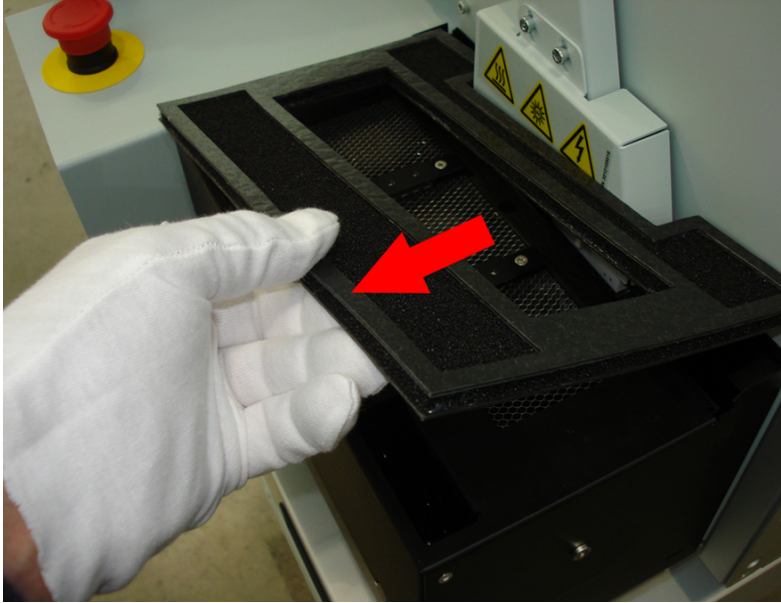

4. Place a new filter on top of the lamp assembly.
5. Replace the magnetic lamp filter cover on top of the lamp assembly.

Remove Ink from the Table

Introduction

This section describes how to remove both cured and uncured ink from the printer vacuum table. It also describes how to unplug a vacuum hole on the table.

Equipment:

Lint-free absorbent clothes

Nitrile Gloves and wrap-around safety glasses

Isopropyl alcohol (95% pure)

How to Remove Uncured Ink

1. Wipe up the majority of the ink by blotting with an absorbent cloth.
2. Wet a new absorbent cloth with alcohol and wipe up the remaining ink.
3. Continue to wet and wipe the surface until the cloth does not show any sign of ink color.

How to Remove Cured Ink

1. Scrape any cured ink from the surface of the table with a scraper (or a razor blade in a holder).
2. Use a vacuum cleaner to remove the scraped particles of ink and any other debris on the table surface.
3. Use a lint-free cloth soaked in isopropyl alcohol to ensure that the table surface is clear of any remaining particles.

How to Unplug Vacuum Holes

1. Identify any vacuum holes that are plugged with ink.
2. With an 1.5mm diameter rigid material (e.g., a paper clip), ream out any of the holes that have been plugged.
3. Clear any resulting debris with a vacuum cleaner or a wet lint-free cloth.

Empty Ink Waste Trays

Introduction

There are two waste trays. The Purge Waste Tray is located under the Maintenance station. It catches ink purged from either Manual maintenance or Automated printhead maintenance. The Spit Waste Tray is located below the ink spit catcher. It accumulates waste ink from printhead spitting.

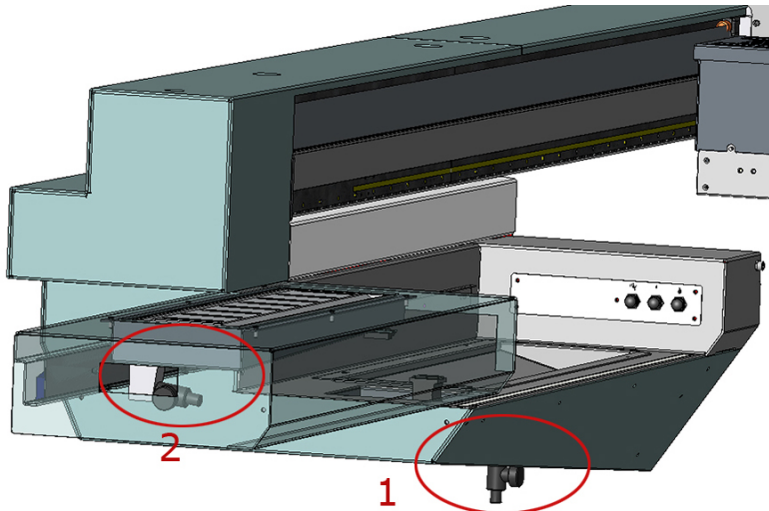

[97] 1 = Purge Waste Tray 2 = Spit Waste Tray

When to do

Empty both waste trays weekly.



CAUTION

Both ink waste trays contain uncured ink. For safety reasons, it is necessary to wear nitrile gloves, a lab coat and safety glasses with side shields to protect users from contacting the ink. UV-curable inks contain chemicals which can lead to sensitization with prolonged or repeated exposure to skin. These chemicals inside the UV ink can begin to penetrate the gloves in less than 10 minutes. Since they have no pigment, exposure is not obvious. Therefore, Océ recommends that only approved nitrile gloves are used for a maximum of 10 minutes after being contaminated with ink and never reused. Damaged gloves should be changed immediately (see the Maintenance Guidelines section and Safety chapter for more details on the recommended nitrile gloves).



NOTE

Although the carriage is oriented so that the nozzles spit into the slots in the spit catcher, some ink will find its way onto the flat surfaces. Open the maintenance drawer to check the surface of the spit catcher daily. If you see any ink wipe it up with a clean cloth or paper towel.

Equipment

- Foam Tipped Swab or Cloth-Poly Wipe
- An empty semi-transparent 1.0 liter plastic container for the Spit Waste tray
- An empty semi-transparent 5 liter plastic container for the Purge Waste tray

- Two plastic funnels: one small and one large (see photos)
- A plastic basin that can hold both containers and also catch any ink spilled during draining

Procedure

1. To empty the Purge waste tray first slide the maintenance drawer open.
2. Put the plastic basin in place on the floor to catch any drips while the tray is emptied.
3. Place a suitable empty container that holds at least 5 liters in the plastic basin with a large funnel placed under the Purge waste tray drain spigot.



4. Place a large funnel into the top of the 5L waste container. Align the funnel to the waste valve so that the ink will go inside the funnel and jug when the valve is opened.
5. Rotate the waste valve knob counter-clockwise until the white line is vertical to start the flow of waste ink.
6. Wait for all of the waste ink to drain. If necessary, empty or use a second waste container.



NOTE

Tip:

If ink has dried on the spigot from previous draining, it may be necessary to carefully use a significant amount of force to open the valve..

7. Shut off the valve when ink no longer drains out (or if the container becomes full).
8. Rotate the purge waste tray valve knob clockwise until it is fully closed and the white line is horizontal.

9. When the ink stops dripping, use a swab to wipe the inside of the valve tip clean as some ink can remain inside and drip out later when the printer is in motion.



10. With the Maintenance station drawer still open, hold a 1.0 liter container with a small funnel under the Spit waste tray valve.
11. Rotate the spit tray waste valve knob counter-clockwise until the white line is horizontal and the ink begins to flow out.

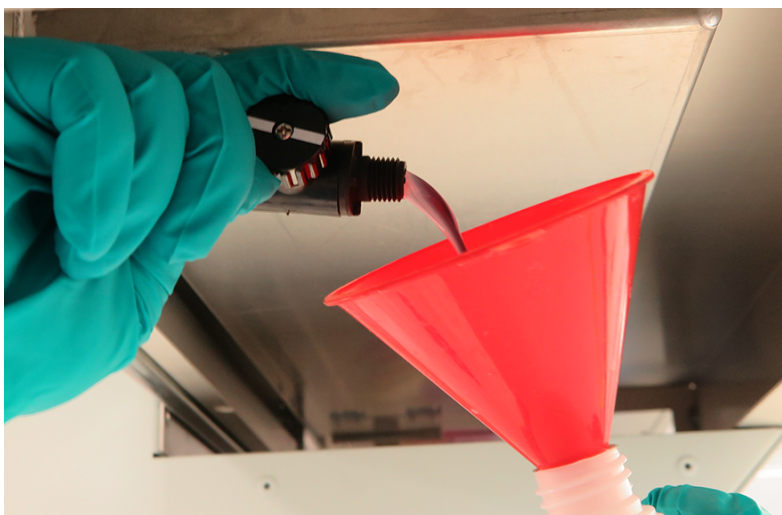

12. When the ink stops dripping out, rotate the spit tray waste valve knob clockwise until it is fully closed and the white line is vertical.

13. With the valve closed, use a swab to thoroughly clean the inside of the valve tip.



14. Empty the 1 liter container into the larger container that holds the Purge waste ink.
15. Dispose of the waste ink and other contaminated material in a suitable, environmentally-friendly manner.

Fill Coolant Bottle

Introduction

Coolant is used to maintain the temperature of the ink in the printheads.

It is important to check the coolant bottle, located in the Primary Ink Bay, to see if the level is low. Keep the coolant level up to ensure proper ink temperature.



NOTE

The Accessory Pack that ships with a new printer contains a 2 liter container of coolant. During an install the coolant system requires 1.8 liters to fill the coolant bottle and lines. We suggest that you order more coolant from your sales representative so that you will have some when you need to top up the system.

Procedure

1. Unscrew the nipple from the coolant bottle lid to remove the coolant tube.



[98] Coolant Bottle is Located in the Primary Ink Bay

2. Remove the coolant bottle from the ink bay.
3. Unscrew the coolant bottle lid.
4. Get the coolant fluid container that shipped with the printer.
5. Fill the coolant bottle.
6. Attach the lid to coolant bottle and return it to the Primary ink bay.
7. Store the coolant fluid until it is needed again.

Clean Gantry Rails

Introduction

Dust and debris can accumulate on the gantry rails, which run along the length of the table. The bearings that run on the rails are equipped with shields that are designed to keep debris from entering the bearing housing. After a period of time and use, debris can accumulate on the outside of the bearing shields as the gantry travels along the table.

When to do

Inspect and clean the rails and bearings at least once a month. If you notice any dirt or ink on the gantry rails, or an accumulation of debris on the grey rail bearing shields, clean them immediately.

Equipment

- Poly-Wipe lint-free cloth or a swab.

Note Attention Caution



IMPORTANT

In the event of an ink spill on the rail, it should be cleaned immediately, before the bearings have a chance to run over the spill. Slight ink stains that remain on the rail after cleaning are not a major problem.

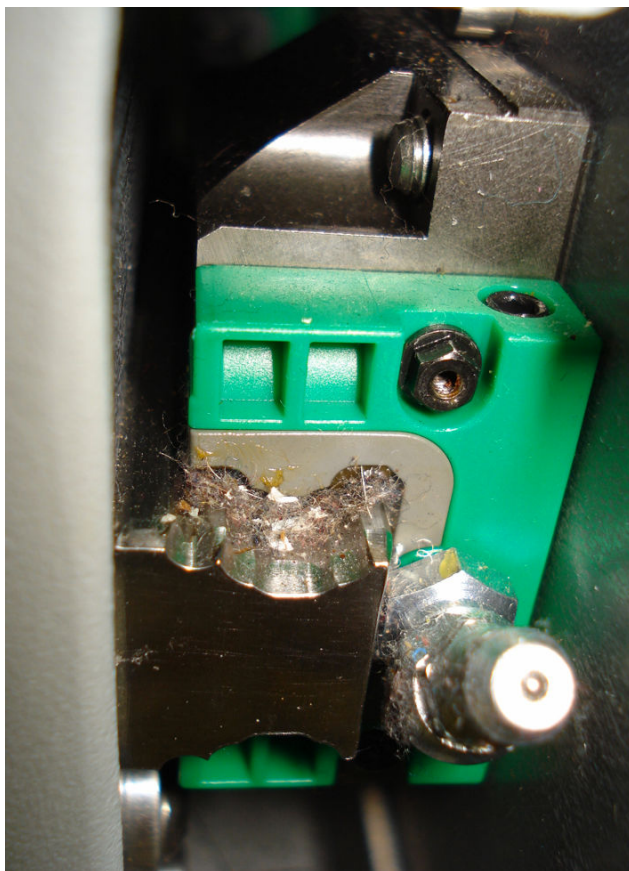

[99] Dust on the runner bearing block shields

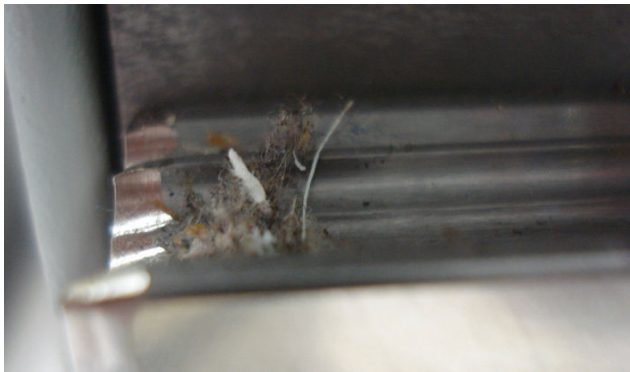

[100] Dust on the gantry rail

Procedure

1. Open the Maintenance Station drawer to ensure that there is no possible gantry or carriage movement.
2. Use a dry lint-free cloth to remove any visible debris that has accumulated next to the bearing shields. It is only necessary to clean the outside bearing shields. When removing debris always wipe away from the shields.
3. Wipe any debris from the gantry rails. Do this gently so that you do not remove the grease that lubricates the bearings as they move along the rails.
4. Close the Maintenance Station drawer.

Change Ink Filter

Introduction

Each ink color has a filter that removes any particulate matter from the ink as it is pumped from the ink bag to the printheads. The ink filters are located in an enclosure below the ink bays with each filter positioned below its ink bag.

When to do

An ink filter must be replaced after 50 liters of ink have been consumed or the effects of a clogged filter appear. If the Nozzle Check print shows one color weaker than normal, this is an indication that the ink filter for the affected color is clogged and the filter must be replaced. If an ink filter becomes clogged, it will trap color pigment and affect the color strength of printed images. If you notice that an ink reservoir takes a long time to fill, check the Maintenance tab in the user interface for when the filter for that color of ink was last changed; it may be time to replace it. Make sure that the ink tubing from that filter is not kinked. It is important to change the filter on schedule and before these symptoms occur; damage to the ink system may result.



NOTE

Ink filters contain air that must be released. If you don't bleed the filters you will see poor image quality. Air in the ink filter can affect the vacuum and result in dripping ink and deteriorated image quality as a result of nozzle dropout. Failure to bleed the ink filters can lead to an overflow of ink that will result in ink dripping from the carriage and you may need to place a service call. You will be notified by the printer Maintenance tab when it is necessary to change or bleed a filter.



CAUTION

Wear nitrile gloves while handling UV ink. Use them only one time and change if contaminated. Review the safety section in Maintenance guidelines.

Procedure

1. Disengage the ink bag for the ink color filter you will replace. To do this press the release tab on the left side of the quick-release ink bag coupler and then pull it out to disconnect the ink bag. Use the color codes on the ink filter enclosure door to identify the correct ink bag and filter.



[101] Remove Ink bag coupler

2. Push on the top of the ink filter enclosure door and it will flip forward to open and provide access to the filters.



[102] Remove Ink Filter Enclosure Cover

3. Locate the bleed tube valve on the top of the ink filter you are going to change and wrap a lint-free cloth around the end of the bleed tube of the ink filter to catch any ink that may spray out when you release the pressure in the next step.



[103] Ink bleed tube valve

4. Turn the bleed tube valve shutoff lever so that it is parallel to the bleed tube to open the valve and release any pressure, then flip the shutoff lever back to the perpendicular closed position after about 30 seconds.



CAUTION

The ink system is under pressure and so it is possible that some ink may spray out when opening the bleed tube valve. Keep the cloth wrapped around the end of the bleed tube so that any ink spay is contained.

5. Pull the target ink filter out of its metal retainer clip.
6. Unscrew the bleed tube cap from the old filter and thread it into the top connector of the new filter. Place the cap that came with the new filter on the old filter to prevent ink from leaking out of the old filter.
7. Repeat the previous step for the top and bottom connections.



NOTE

Wipe off any spilled ink.

8. Insert the new filter into the empty retainer clip and make sure the flow arrow on the filter points downward. Be careful not to pinch the ink lines.
9. Reconnect the ink bag and proceed to How to Bleed an Ink Filter (necessary to remove air from a new filter).

Bleed Ink Filter

Introduction

Ink filters contain air that must be released. Although, you can select Done or Postpone even if the task is not complete, it is in your best interest to follow the recommended schedule. If you don't bleed the filters you will see poor image quality. Air in the ink filter can affect the vacuum and result in dripping ink and deteriorated image quality as a result of nozzle dropout. Bleeding the ink filters is a strategy to avoid persistent nozzle dropout. Failure to bleed the ink filters can lead to an overflow of ink that will result in ink dripping from the carriage and you may need to place a service call. You will be notified by the printer UI when it is necessary to change or bleed a filter.

When to do

New ink filters contain air that must be released. Also after a period of use all ink filters will contain air. Follow the schedule for bleeding ink filters indicated in the Maintenance Tasks tab.

Before you begin

The filters are bled using a 60 ml syringe. If bleeding after an ink bag change, let the ink fill finish before bleeding the filter. The filters should be bled while the printer is idle; that is, there should be no active printing.



CAUTION

**Wear nitrile gloves, glasses with side shields and a smock when handling UV ink. Use gloves only one time and change if contaminated.
Review the safety section in Maintenance guidelines.**

Procedure

1. Push on the top of the ink filter enclosure door and it will flip forward to open and provide access to the filters.



[104] Open the Ink Filter Enclosure Cover

2. Locate the bleed tube valve on the top of the ink filter you are going to bleed (the cap that holds it in place indicates the color of the ink line into that filter). Attach the syringe to the bleed port and open the stopcock.

If you want to reuse the syringe, start with the lighter ink colors first. Darker inks will stain the clear plastic wall of the syringe and make it difficult to see the ink as it comes in.



3. Pull the plunger out until ink is seen in the syringe.
If there is excessive air, more than one syringe full of air may be extracted. In this case, close the stopcock before disconnecting the syringe and expelling the air. Open it again to continue.



NOTE

Pull back on the syringe plunger in increments and wait for the pressure to equalize before pulling more to prevent over-pulling on the syringe. Note that the White ink channel may need slightly more pulling to overcome the pressure.

4. After the air has been fully withdrawn from the filter there will be a noticeable increase in the force required to pull on the syringe, and ink will begin to flow into the syringe.

5. Once ink has been drawn into the syringe (it may spring back due to the vacuum in the syringe), release the plunger slowly, close the stopcock, disconnect the syringe, and carefully discard the ink into a waste bucket.



IMPORTANT

The same syringe can be used to bleed all the ink channels if they are done in succession. The syringe cannot be stored and reused as the ink chemistry will degrade the syringe. If only some of the ink channels require bleeding, discard the syringe immediately after finishing those channels. Do NOT reuse it on other ink channels at a later date.

Change Both UV Lamp Bulbs

Introduction

The printer uses two UV lamps, one on each side of the carriage, to cure the UV ink during printing. The bulbs in these UV lamps have a limited lifetime and must be replaced by the operator if they fail or when they can no longer cure the ink at maximum available power.

When to do

Although the expected life of the UV lamp bulbs is 500 hours, there are factors that can reduce that time. Operational practices, such as turning the lamps off and on frequently, using them at high intensity all of the time, or touching the bulbs with your fingers, can shorten their life. Océ recommends that both UV Lamp bulbs be replaced at the same time to ensure that the curing effect is balanced when printing in both directions. In the case of a premature failure or accidental breakage of one lamp, the operator can decide to replace only one lamp but should confirm image consistency after the replacement. Uneven curing can cause gloss banding in the printed image.



NOTE

The Flatbed Settings icon on the printer interface allows the operator to control the power output of each UV lamp independently. To extend lamp life, use the lowest setting that provides adequate curing for a particular media. However, avoid handling media with insufficient curing as partially cured UV ink on your skin can cause irritation and sensitization. Replace both lamp bulbs after 500 hours of use to help ensure that the UV ink is fully and evenly cured.

Note Attention Caution



CAUTION

The UV lamps and the carriage may be hot if the printer has been active. Avoid touching the lamp assembly until it is cool. These UV lamp bulbs contain mercury, and if they are broken the vapor is toxic if inhaled. The lamp bulbs must be disposed of according to local environmental regulations.

How to Access the Lamp Housings

The housings for the two UV lamps are located on each side of the carriage. When you view the printer from the end where the Start button is located, the Right lamp is located on the Home side where the carriage parks when it is not printing. The Left lamp is located on the other (Away) side of the carriage. To access the Right lamp, make sure the carriage is in its parked position and follow the instructions below to remove a bulb.

How to Remove the UV Lamp Bulb

It is not necessary to shut the printer power off while replacing the UV lamp bulbs. However, make sure you turn them off by de-selecting the lamp icon in the user interface before you start and allow a few minutes for the bulbs to cool down.



NOTE

Wear cotton or nitrile gloves when handling UV lamp bulbs. Avoid bare skin contact with the UV lamp bulbs. When heated, compounds from the skin can form permanent etching on the surface of the UV bulb. A contaminated bulb may fail prematurely.

Procedure

1. From the User Interface, deselect the lamp icon to turn the lamps off and allow to cool for 5 minutes.
2. Click on the Maintenance Tab and then select UV Bulb Replacement from the Maintenance Tools in the upper right side of the display.

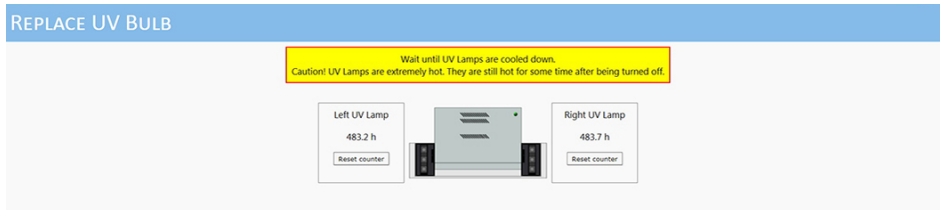

NOTE

Accessing the Replace UV Bulb window will open the lamp assembly shutters so that the bulbs will be easily accessible later in this procedure.

3. Lift and remove the safety guard from the carriage.



NOTE

When the carriage guard is removed, the carriage will raise and the green beacon will go off.

4. Lift the magnetic lamp filter cover off of the lamp housing.



5. Lift the lamp filter off of the lamp assembly and set aside.



6. Open the lamp assembly by lifting on the hinged cover and rotating toward the carriage.

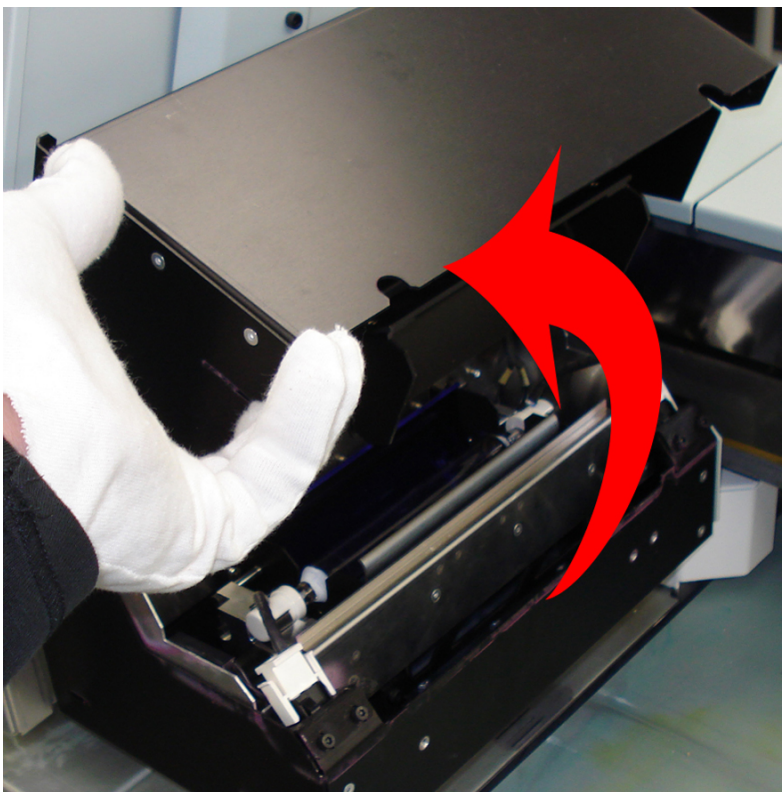

7. Disconnect the UV lamp bulb connectors by pressing in the two side tabs and pulling up.

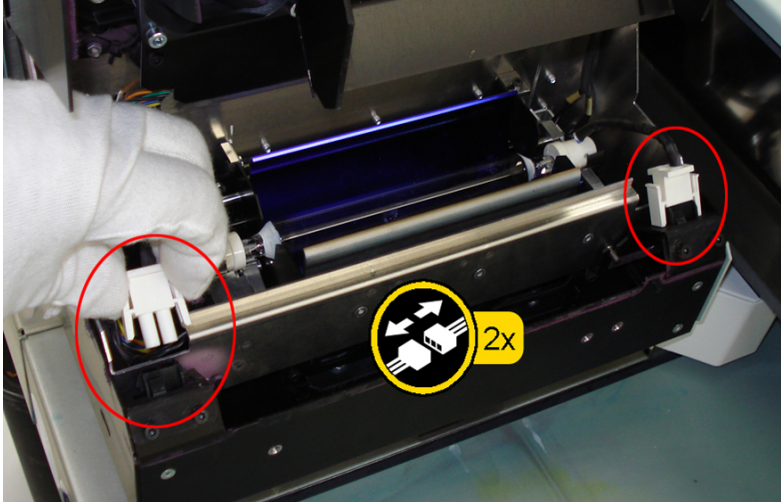

8. Hold the wire attached to each end of the bulb and using index fingers, lift up on the ceramic bulb ends.

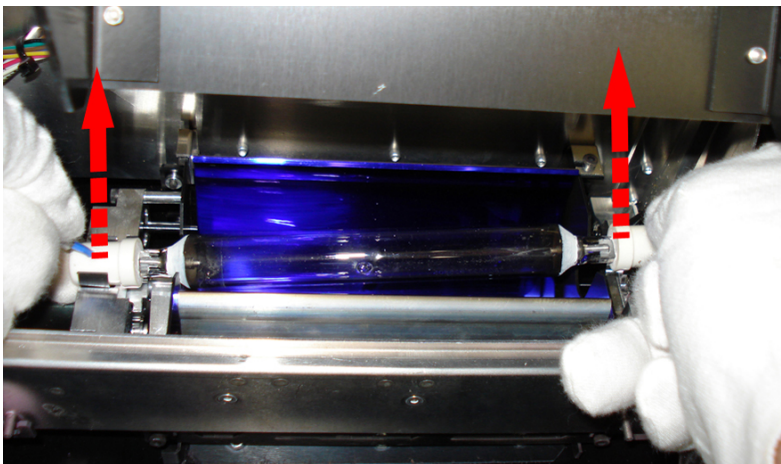

9. Dispose of the old bulb per local regulations.
10. Clean the lamp shutter and bulb with the alcohol wipe included in the kit.

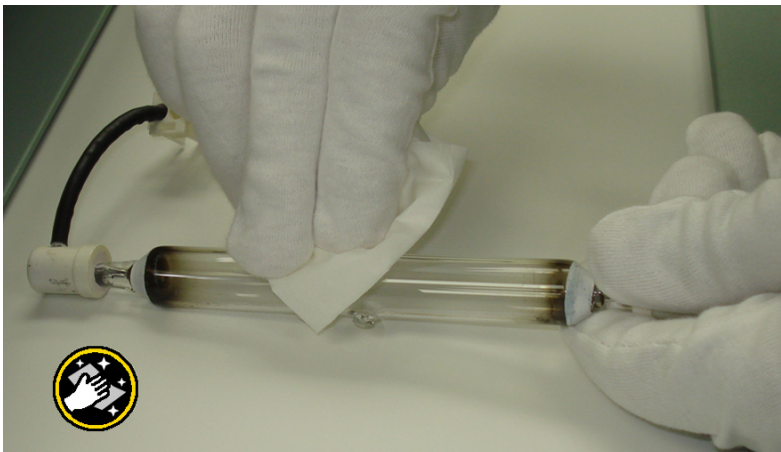



11. Pick up the new bulb by its ceramic ends and power wires, and then insert the bulb into the retainer clips.
12. Reconnect the bulb power connectors at both ends.
13. Close the lamp assembly by rotating the top down.
14. Reinstall the lamp filter on top of the lamp housing.
15. Reinstall the magnetic lamp top cover to secure the filter.
16. Repeat this procedure if necessary to change the bulb on the other side of the carriage.
17. Replace the safety fence.
18. From the User Interface, reset the lamp bulb hours for the bulb replaced, then click on Back to exit.
19. Dispose of the old UV lamp bulbs according to local environmental regulations for products that contain mercury.

**CAUTION**

LAMP(S) INSIDE THIS PRODUCT CONTAIN MERCURY AND MUST BE RECYCLED OR DISPOSED OF ACCORDING TO LOCAL, MUNICIPAL, STATE, PROVINCIAL, OR FEDERAL LAWS. For lamp recycling and disposal information please call 1-800-OK-CANON for the USA and Canada. Refer to Chapter 3 Safety Information / UV Curing System for more information.

In Europe UV lamp bulbs must be treated separately according Directive 2012/19/EU (Waste Electrical and Electronic Equipment). European Waste Catalogue (EWC) number of the mercury containing fluorescent lamp: 20 01 12.

Roll Media Option Maintenance

RMO Maintenance Guidelines

Introduction

This section provides information about what is required for proper RMO maintenance and cleaning.



NOTE

Any time there is any foreign matter or debris on the platen or the capstan it must be removed immediately. Any spilled UV ink must be removed immediately, before it can cure from exposure to light.

RMO Maintenance

The following table provides our recommended maintenance activities. Frequency will depend on environmental conditions and operator work habits. How to clean the capstan is explained in detail in the next section.

Maintenance Action	Contaminant
Clean the platen	Ink
	Glue (release liner)
	Silicon (release liner)
Clean the capstan	Paper dust
	Coffee or tea
	Ink (cured, uncured)
	Glue (release liner)
	Silicon (release liner - e.g. Avery control tag 180)
Clean the media loading bay	Dust
	Ink

How to Clean the Rubber Capstan

Introduction

The capstan is a rubber-coated roller that helps to track and guide the media position. The capstan must be kept clean and its rubber surface free of blemishes or defects to ensure accurate media transport and optimal print quality.

When to do

Any time there is any foreign matter or debris on the capstan it must be removed immediately.

Required tools

Swiffer Brush (or equivalent dust remover)

Lint-free absorbent clothes

Rubber gloves

Mild detergent

Lint-free cloth

Isopropyl alcohol (95% pure)



NOTE

Always wear safety glasses with side shields and nitrile gloves when working with ink or liquid solvents. If a significant amount of ink has spilled, consider donning an apron or smock.



IMPORTANT

The only way to remove cured ink is if the area can be scraped without causing damage (therefore do not allow ink to dry on the platen or the capstan! Partly cured ink can be removed with alcohol. Make sure that any spilled ink is removed immediately before it has a chance to cure due to exposure to light. The longer it is left exposed, the more difficult (or impossible) it will be to remove the ink.

How to Remove Solid Debris

Procedure

1. Dust the surface of the capstan using a Swiffer or other lint-free brush or cloth. Surface may be brushed in any direction.



[105] Remove lint, dust, paper particles and debris

How to Remove Stains (coffee, tea, soda pop, etc.)

Supplies Needed: Rubber gloves, soap, hot water, and lint-free cloth.

Procedure

1. Put on nitrile gloves
2. Mix a cleaning solution that is 50:1 hot water to soap.



NOTE

Use a mild detergent such as Ivory - avoid soaps that have dyes, moisturizing oils, or perfumes as they may damage the capstan. Read the label! Our R&D Lab has tested only Ivory Detergent. If you are uncertain about a detergent try it out in a 50:1 solution on a small area at the end of the capstan.

3. Wet the cloth in the cleaning solution and wring out excess liquid. Scrub the surface of the capstan using the cleaning cloth.
4. Allow adequate time for the capstan to dry.



NOTE

If scrubbing action leaves debris on the surface, wait for the surface to dry completely, then follow the procedure listed above for "Removing Solid Debris".

How to Remove Uncured Ink on the Capstan

Before you begin

Supplies needed:

- Nitrile gloves,
- safety goggles with side shields,
- several absorbent clothes and
- Isopropyl Alcohol (95% pure).

Procedure

1. Put on gloves and goggles.



[106] Ink Spill on Capstan

2. Wipe up the majority of the ink by blotting with the absorbent cloth.

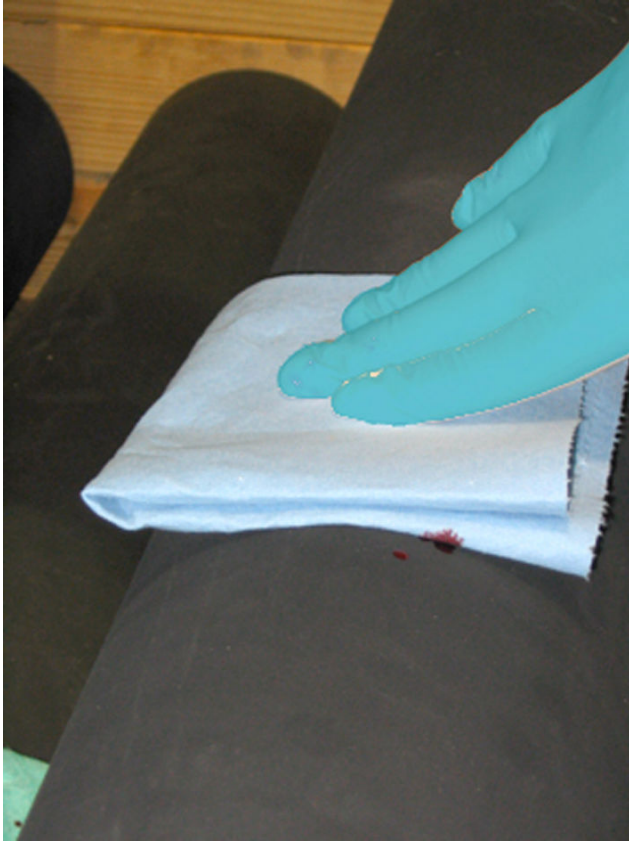

[107] Wipe up ink with cloth

3. Wet a new absorbent cloth with alcohol and wipe up the remaining ink.



[108] Wet fresh cloth with alcohol



NOTE

It may be difficult to tell whether or not all the ink has left the surface. Continue to wet and wipe the capstan surface until the cloth does not show any sign of ink color.

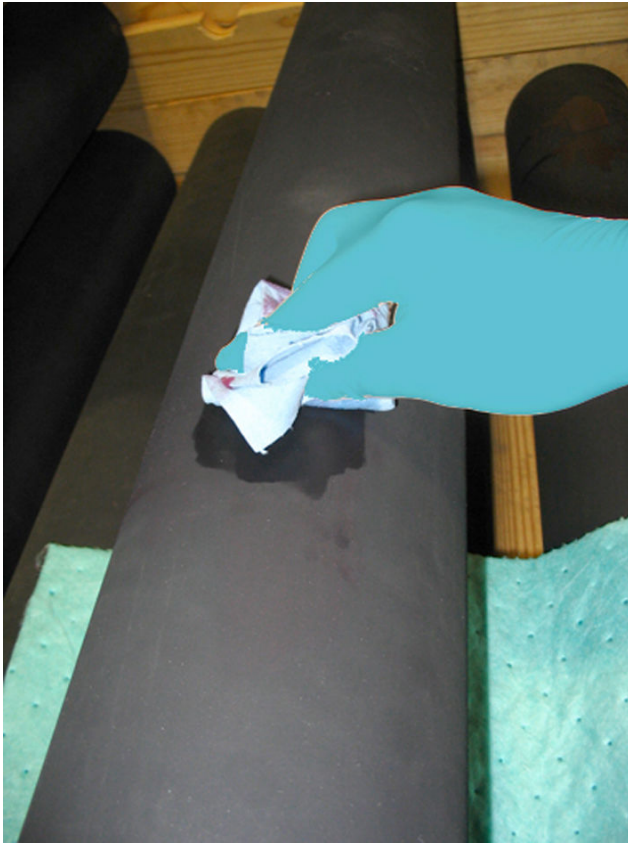

[109] Wipe up remainder of ink

4. Allow adequate time for capstan to dry.



NOTE

If the scrubbing action leaves fibers from the cloth on the surface, wait for the surface to dry completely, then follow the procedure listed above for Removing Solid Debris. When the capstan is kept clean and its rubber surface free of blemishes or defects you will be ensured of accurate media transport and optimal print quality. If its surface is badly damaged the capstan will need to be replaced.

Chapter 13

Regulation Notices

CE Declaration of Conformity (EEA including Switzerland)

- According to 2006/42/EC a document setting out the contents of the CE Declaration of Conformity is included in this User Documentation.

Radio Interference suppression (all countries except USA)

- Warning: This equipment is compliant with Class A. In a residential environment this equipment may cause radio interference.

FCC approval (USA)

- This equipment has been tested and found to comply with the limits for a Class A digital device, pursuant to Part 15 of the FCC Rules. These limits are designed to provide reasonable protection against harmful interference when the equipment is operated in a commercial environment. This equipment generates, uses, and can radiate radio frequency energy and, if not installed and used in accordance with the User Documentation, may cause harmful interference to radio communications. Operation of this equipment in a residential area is likely to cause harmful interference in which case the user will be required to correct the interference at his own expense.
- Do not make any changes or modifications to the equipment unless otherwise specified in the User Documentation. If you make such changes or modifications, you could be required to stop operation of the equipment.
- This equipment contains a certified modular transmitter. The transmitter's FCC ID label is located near the power rating label. The modular transmitter is located in the ink supply unit and can only be accessed by a service technician.

ICES-001/NMB-001 and ICES-003/NMB-003; Interference-causing equipment (Canada)

- CAN ICES-3 (A)/NMB-3(A)

Conformity declaration for Radio Law (Japan)

This end device contains an RFID module which is already approved by MIC (AC-17014) for Radio Law.

Conformity declaration for Radio devices (USA and Canada)

- This equipment contains a certified modular transmitter. The transmitter's FCC ID label is located near mains power inlet. The modular transmitter is located in Ink Bay and can only be accessed by a service technician.
- This equipment contains a certified modular transmitter. The transmitter's FCC ID is U2P-3010120604, the IC ID is 6947A-3010120604.

Laser Safety (All countries)

- **CDRH regulations**

This machine is certified as a Class 1 Laser product under Radiation Performance Standard according to the Food, Drug and Cosmetic Act of 1990. Compliance is mandatory for Laser products marketed in the United States and is reported to the Centre for Devices and Radiological Health (CDRH) of the U.S. Food and Drug Administration of the U.S. Department of Health and Human Services (DHHS). This means that the device does not produce hazardous laser radiation. The related label indicates compliance with the CDRH regulations and must be attached to laser products marketed in the United States.

CAUTION

Use of controls, adjustments or performance of procedures other than those specified in this User Documentation may result in hazardous radiation exposure. This is a semiconductor laser. The maximum power of the laser diode is **0.5 mW**.

Mercury (All countries)

One or more lamp(s) inside this product contain(s) mercury. Dispose these lamp(s) according to all federal, state and local regulations.

Mercury (USA and Canada)

Lamp(s) inside this product contain(s) mercury and must be recycled or disposed of according to local, municipal, state, provincial, or federal laws. For lamp recycling and disposal information please call 1-800-OK-Canon for the U.S. and Canada.

Mercury (EEA including Switzerland)

Mercury containing lamp(s) must be removed and treated separately according Directive 2012/19/EU (Waste Electrical and Electronic Equipment). European Waste Catalogue (EWC) number of the mercury containing fluorescent lamp: 20 01 12.

Lamps (All countries)

This product may contain lamps that are only intended for use in combination with and for this specific product (and related equipment) and such lamps are not intended for use in other applications.

Battery labeling (EEA including Switzerland)

- This product contains a battery. Please do not remove the battery. If the battery needs replacement, this should be done only by skilled service technicians who are aware of the removal instructions provided by Océ.
- This product contains a battery or batteries. It (They) is (are) located in (a) printed circuit board(s) that is (are) essential for the continuous error-free functioning of the product. The battery or batteries should be removed only by skilled service technicians who are aware of the removal instructions provided by Océ.



Location	Battery capacity [Ah]	Contains
Controller	200 mAh	Lithium

Caution: Océ does not accept any liability for any damage or consequences, if the batteries are removed by persons other than Océ service personnel.

Battery Labeling (USA)

This product contains a Lithium battery, containing Perchlorate Material – special handling may apply, see "<http://www.dtsc.ca.gov/hazardouswaste/perchlorate>".

Battery labeling (Taiwan)

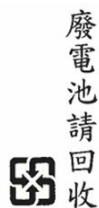

Translation: Waste batteries, please recycle.

End of Life; WEEE (EEA including Switzerland)

This symbol indicates that this product is not to be disposed of with your household waste, according to the WEEE Directive (2012/19/EU) and your national law. This product should be handed over to a designated collection point, e.g., on an authorized one-for-one basis when you buy a new similar product or to an authorized collection site for recycling waste electrical and electronic equipment (EEE). Improper handling of this type of waste could have a possible negative impact on the environment and human health due to potentially hazardous substances that are generally associated with EEE. At the same time, your cooperation in the correct disposal of this product will contribute to the effective usage of natural resources. For more information about where you can drop off your waste equipment for recycling, please contact your local city office, waste authority, approved WEEE scheme or your household waste disposal service. For more information regarding return and recycling of WEEE products, please visit "<http://www.canon-europe.com/environment>". Reference: Directive 2012/19/EU.



End of Life; WEEE (India)

This product is not to be disposed of with your household waste, according to the E-Waste (Management) Rules, 2016. This product should be handed over to a designated collection point, e.g., to an authorized collection site for recycling waste electrical and electronic equipment (EEE). Improper handling of this type of waste could have a possible negative impact on the environment and human health due to potentially hazardous substances that are generally associated with EEE. At the same time, your cooperation in the correct disposal of this product will contribute to the effective usage of natural resources. For more information regarding return and recycling of WEEE products, please visit "<http://www.canon.co.in/environment>" or write to us at "customer.delight@canon.co.in". Also, this product complies with the "E-Waste (Management) Rules, 2016" and prohibits use of lead, mercury, hexavalent chromium, polybrominated biphenyls or polybrominated diphenyl ethers in concentrations exceeding 0.1 % by weight and 0.01 % by weight for Cadmium, except for the exemptions set in Schedule II of the Rule.



End of Life; Handling of disposal of parts (Japan)

廃棄物の取り扱いについて
使用済みの消耗品と消耗部品は、法令・条例に従って、産業廃棄物としてお客様が処理処分をお願い致します。

Translation: Handling of disposals. Used consumables and expendables must be discarded by the customer as industrial waste in accordance with the laws as well the regulations of local government.

RoHS (China)

The Environmental Protection Use Period (EPUP) applicable for the machine designated for deliveries to the Peoples Republic of China is 20 years. This EPUP, which does not include consumables or expendables, does not affect any warranty that is provided for the system and may not be construed or interpreted as a separate guarantee for the machine.



RoHS (Vietnam)

Canon and Océ brand products sold in Vietnam market comply with following Circular and Decision - "Circular No.30/1011/TT-BCT dated August 10, 2011 of the Ministry of Industry and Trade stipulating temporarily the permissible content limitation of some toxic chemicals in the electronic, electrical products" - Decision No.4693/QD-BCT correcting Circular 30/2011/TT-BCT.

For the statement on Canon Marketing Vietnam website, please see the last paragraph on the web page of the following URL: "<http://www.canon.com.vn/personal/web/company/about/>".

REACH compliance (EEA including Switzerland)

- REACH regulation (EC No 1907/2006) article 33 requires information to be communicated to customers/end users about the presence of SVHC substances included in the REACH candidate list when such substances are above the threshold of 0.1% in articles. If such information has to be communicated it can be found on "www.canon-europe.com/about_us/sustainability/business/reach_customer_statement/".

Under normal conditions of use, there will be no exposure and no special measures are required for safe use.

Operating environment (All countries)

- The environmental requirements for correct operation of the machine are as follows:
 - Operating temperature (T): **18°C (64°F) to 30°C (86°F)**
 - Relative Humidity (RH): **30% to 70%**
 - Operating altitude: below **2000 m**

Glanzgrad bei Peripheriegeräten (Germany)

Das Gerät ist nicht für die Benutzung im unmittelbaren Gesichtsfeld am Bildschirmarbeitsplatz vorgesehen. Um störende Reflexionen am Bildschirmarbeitsplatz zu vermeiden darf dieses Produkt nicht im unmittelbaren Gesichtsfeld platziert werden.

Translation: The equipment is not intended for use within the direct visual field of a workplace equipped with a monitor screen. In order to avoid annoying reflections at the workplace (monitor screen), this product must not be placed within the direct visual field of monitor screens.

Acoustic noise emission (All countries)

- Sound pressure ($L_{pA} = 71 \text{ dB(A)}$) is used to characterize the sound level that will be experienced at operator position (around the product at a distance of 1 m and a height of 150 cm (59.1 inch)) and is defined as the dynamic variation of the static pressure of air measured in force per unit area. Sound pressure is normally represented in decibels [dB]. Typical values are a sound pressure level of 0 dB, which is the average threshold of human hearing, and 60 to 70 dB for normal conversation, 110 dB at an extremely loud music concert, and 150 dB for the noise of a jet engine at close range.

Appendix A

Application Information

Application Resources on the Web Site

Introduction

There are many resources available on the Océ Arizona Customer Support web site: Application Hints and Tips, Media Recommendations, Media Profiles, Customer Application Bulletins, and more. To access this information, navigate to: <https://dgs.oce.com> then select Printer Support - Customer Access.

There is a Media Notes document that contains useful information about printing on various media.

There is also a link to the Océ Media Guide web site that contains useful information about all Océ-recommended media and consumables.

The Customer Application Bulletins posted on the web site deal with many aspects of handling and managing media and printing with your Arizona printer. At the time of this publication, the following bulletins were available to view or download:

Application Bulletin 1 - New Media Profiles Available

Application Bulletin 2 - How to Select A Media Model and ICC Profile

Application Bulletin 3 - How to Achieve Optimal UV Lamp Power

Application Bulletin 4 - ONYX ProductionHouse Anti-Virus Software Issues

Application Bulletin 5 - How to Handle and Prepare Media for Printing

Application Bulletin 6 - How to Improve UV Ink Adhesion

Application Bulletin 7 - About Media Models and Application Notes

Application Bulletin 8 - How to Hold Media Flat on the Printer Table

Application Bulletin 9 - How to Handle Media after Printing

Application Bulletin 10 - How to Deal with Static

Application Bulletin 11 - Printing Backlit Materials

Application Bulletin 12 - Printing Multiple Pieces of Media Simultaneously

Application Bulletin 13 - Printhead Maintenance - Revised Version

Application Bulletin 14 - New Ruler Guides Available in Special Prints

Application Bulletin 15 - How to Print Lenticular Images

Application Bulletin 16 - Media Model and ICC Profile Creation Guidelines

Application Bulletin 17 - Managing Arizona 250GT Ink Inventory

Application Bulletin 18 - How to Bleed Trapped Air from an Ink Filter

Application Bulletin 19 - Reduce Static with an Océ Static Suppression Kit

Application Bulletin 20 - How to Print on Backlit Materials Using Quality-Density Mode

Application Bulletin 21 - More Media Models Added to Support Web Page

Application Bulletin 23 - Double-Sided Printing on the Océ Arizona Roll Media Option

Application Bulletin 24 - Printer Shutdown Procedures

Application Bulletin 25 - Use a White Ink Underlay to Improve Image Quality

Application Bulletin 26 - Variable Reduced Density in White Spot Data for Raster Images

- Application Bulletin 27 - Ink Filters Must be Changed Every 12 Months
- Application Bulletin 28 - Selecting Appropriate Océ Ink for Your Applications: Océ IJC255 or Océ IJC256
- Application Bulletin 29 - Recommended Media for Use With the New Océ IJC256 Inks
- Application Bulletin 30 - How to Create Reduced Density White Ink Output
- Application Bulletin 31 - How to Print White Ink Gradients
- Application Bulletin 32 - How to Work Safely in a UV Ink Environment
- Application Bulletin 33 - Improve White Ink Reliability When Printing Small Amounts of White
- Application Bulletin 34 - Océ Arizona 200/250/300/350 GT & 350 XT Software Revision Highlights
- Application Bulletin 35 - Océ Arizona Printer Care and Use Poster
- Application Bulletin 36 - How to Avoid Media Wrinkling on the RMO
- Application Bulletin 37 - Alternative Media Load Procedure for the Océ Arizona RMO
- Application Bulletin 38 - Clean the UV Lamp Reflectors When A Bulb is Replaced
- Application Bulletin 39 RMO Motion Error/Bouncing Dancer Fix
- Application Bulletin 40 ONYX X10 Media Model and ICC Profile Creation Guidelines
- Application Bulletin 41 Optimizing XT Center Zone Vacuum
- Application Bulletin 42 Dibond Media Models Added to the Customer Support Website
- Application Bulletin 43 Roll Media Option Tips and Troubleshooting
- Application Bulletin 44 Océ UV Adhesion Promoters
- Application Bulletin 45 Batch Mode Operation
- Application Bulletin 46 Enhanced Dual Origin
- Application Bulletin 47B High Gloss Varnish – Best Printing Practices
- Application Bulletin 48B Converting to a Different Océ IJC25X Ink Formulation
- Application Bulletin 49 Océ Arizona ONYX ICC Profile Creation Tip – Add Gutters
- Application Bulletin 50 ONYX 11 – ONYX Media Profile and ICC Profile Creation Guidelines
- Application Bulletin 51 - Tips to Improve Nozzle Reliability
- Application Bulletin 52 - Varnish Ink - Printing Options
- Application Bulletin 53 - Océ Arizona Revised Printhead Maintenance Procedure
- Application Bulletin 54 - Océ Arizona 6100 Series Care and Use Poster
- Application Bulletin 55 - Minimize Exposure to UV Light When Inspecting Printhead Nozzles
- Application Bulletin 56 - Converting an Arizona 6100 Series Printer to a Different Océ IJC26X Ink
- Application Bulletin 57 - Arizona IJC2xx White Ink Maintenance
- Application Bulletin 58 - How to Bleed an Ink Filter
- Application Bulletin 59 Océ Arizona Printers Ventilation Requirements
- Application Bulletin 60 Care and Use of Flush and UV Ink
- Application Bulletin 61 Updated Océ Arizona Printer Care and Use Poster
- Application Bulletin 62 Sensitivity to LED Flashlights Varies with Ink Types

Application Resources on the Web Site

Application Bulletin 63 Potential Safety Issue when using Blank Space Skipping

Application Bulletin 64 Océ Arizona Maintenance Videos Updated and Expanded

Application Bulletin 65 AMS No Purge Option for White Channel

Application Bulletin 66 How to Empty the Ink Waste Trays

Customer Support

The information found on the Océ Customer support web site is based on our experience with the Océ Arizona printers. It offers suggestions or solutions for dealing with various situations. Since this information is subject to change and more new material is added as it becomes available, please check the web site occasionally for the most current information.

Index

print quality..... 182

A

AC power.....63
 AC power plug.....63
 Alphanumeric input.....44

B

Beacon Light Status..... 28

C

Carriage Collision 78
 Carriage Guard..... 40
 Carriage Interlock..... 28
 Coolant Reservoir..... 192
 Custom Vacuum Zones..... 68, 70, 71

E

Emergency Stop Function..... 28
 Emergency Stops..... 40
 Emergency-Stop button.....28

F

Flatbed button.....64
 foot switch.....90

G

Gantry Rails.....193
 Graphical User Interface..... 42

I

ICC profile 77
 Imperial Vacuum Zones..... 68, 70, 71
 Ink Bag.....164
 ink delivery.....162
 Ink Filters..... 40, 163
 ink safety..... 162
 Ink System Status.....45
 Ionization..... 114, 115
 Ionizer bar..... 114, 115

M

Maintenance..... 168
 Maintenance Schedule.....168
 Maintenance Station..... 40
 Maintenance Station 169, 171
 Material Safety Data Sheets..... 162
 Measurement Units.....55
 Media Adhesion.....78
 Media shaft..... 90
 Media Storage..... 77
 Media Storage 77
 media thickness.....64
 Metric Vacuum Zones..... 68, 70, 71
 MSDS (Material Safety Data Sheets)..... 162
 MSDS Ink Information 162

N

network connection settings..... 54
 Nozzle check..... 169, 171, 182
 Nozzle dropout..... 169, 171
 nozzle plate..... 169, 171
 Nozzle print..... 45
 Nozzle print narrow..... 45

O

Onscreen Keyboard.....42
 Operator Control Station..... 40
 Operator Interface Module Tabs..... 42

P

Pause/Resume button..... 45
 Periodic Maintenance.....42
 Print button 65
 Print Job Control..... 44
 Print Modes.....45
 Print Modes Explained..... 45
 Print Parameters..... 45
 Printhead maintenance..... 169, 171

R

RMO hardware.....90
 RMO media size supported..... 92
 RMO specifications.....92

S

safety interlock system..... 28
Safety Training..... 62
Special Prints..... 42
Specifications..... 10
Static and Humidity..... 114, 115
Static Suppression..... 114, 115
suction-head..... 171

T

Thermal Expansion..... 78
Training..... 62

U

Upgrade..... 42
User Interface Settings..... 55
UV Flush..... 162

V

Vacuum Gauge..... 67
Vacuum Overlay..... 66
Vacuum Pump Timeout..... 66
Vacuum System..... 66
Vacuum Zone Control..... 40
Vacuum Zones..... 64, 66
Ventilation..... 162

Canon

Canon Inc.

www.canon.com

Canon U.S.A., Inc.

www.usa.canon.com

Canon Canada Inc.

www.canon.ca

Canon Europe Ltd

www.canon-europe.com

Canon Latin America Inc.

www.cla.canon.com

Océ Australia Pty Ltd

www.oce.com.au

Canon China Co., Ltd

www.canon.com.cn

Canon Singapore Pte. Ltd

www.canon.com.sg

Canon Hongkong Co., Ltd

www.canon.com.hk