



ColorWave 3600

Operation guide



Copyright and Trademarks

Copyright

Copyright 2020 Canon Production Printing.

No part of this publication may be copied, modified, reproduced or transmitted in any form or by any means, electronic, manual or otherwise, without the prior written permission of Canon Production Printing. Illustrations and printer output images are simulated and do not necessarily apply to products and services offered in each local market. The content of this publication should neither be construed as any guarantee or warranty with regard to specific properties or specifications nor of technical performance or suitability for particular applications. The content of this publication may be subject to changes from time to time without notice.

CANON PRODUCTION PRINTING SHALL NOT BE LIABLE FOR ANY DIRECT, INDIRECT OR CONSEQUENTIAL DAMAGES OF ANY NATURE, OR LOSSES OR EXPENSES RESULTING FROM THE USE OF THE CONTENTS OF THIS PUBLICATION.

Language

Translation of the original instructions that are in British English.

Trademarks

Canon is a registered trademark of Canon Inc. ColorWave is a trademark or registered trademark of Canon Production Printing Netherlands B.V.

Adobe, Acrobat and PostScript are either registered trademarks or trademarks of Adobe Systems Incorporated in the United States and/or other countries.

Microsoft, Windows and Internet Explorer are trademarks or registered trademarks of Microsoft Corp incorporated in the United States and/or other countries.

All other trademarks are the property of their respective owners and hereby acknowledged.

Contents

Chapter 1

Introduction	9
About the ColorWave 3600.....	10
About the users.....	11
Notes for the reader.....	12
Available documentation.....	14

Chapter 2

Get to know the printing system	17
The hardware.....	18
The components of the printer (front).....	18
The components of the printer (back).....	20
The media drawer	21
ClearConnect user panel.....	22
The components of the scanner (optional).....	24
The delivery destination.....	26
Select the finishing device configuration.....	28
The Scanner Professional (optional).....	29
The folding device (optional).....	30
The take-up module (optional) and the Roll Wind module (optional).....	31
Configure the roll-to-roll mode.....	31
The earthquake provision.....	32
Connect your printing system.....	33
Printer working area (Footprint).....	33
Connect the mains supply cable and the network cable.....	34
Switch on the printing system.....	36
Turn off the printing system.....	38
Move the system	40
Workflow of the ClearConnect user panel.....	44
The home screen.....	44
The job queue and the system menu.....	46
Presets, templates and advanced settings.....	48
Job preview.....	50
The cloud.....	51

Chapter 3

Define your workflow with WebTools Express	53
Getting started.....	54
WebTools Express.....	54
Set another language for WebTools Express.....	55
Access management.....	56
Log in as an authorized user.....	57
Log out after your session.....	58
Change the password for authorized users or the password encryption key.....	59
The job states.....	60
The system monitor	61
Shut down or restart the system.....	63
Define the defaults.....	64
About the default settings in WebTools Express.....	64

How to edit a setting.....	65
View and check the settings	66
Save the settings in a file	67
Load the settings from a file	68
Restore the factory defaults	69
Set the print job default settings	70
Set the copy job default settings	73
Set the scan job default settings	74
Configure the Smart Inbox settings.....	75
The Smart Inbox and the queue concept.....	75
The Smart Inbox in the Jobs tab.....	76
Create and open a Smart Inbox.....	78
Close or delete a Smart Inbox.....	81
Configure the job management settings.....	82
Configure the network and security settings.....	83
Configure the network settings in WebTools Express.....	83
Set the link speed and duplex mode.....	84
Set the security settings for Microsoft Internet Explorer	85
Set the security settings for Mozilla Firefox.....	86
Set the security settings for Google Chrome.....	87
Set the security settings for Microsoft Edge.....	88
Enable user authentication.....	89
Enable Access control	90
Enable IPsec.....	91
Access control and IPsec settings.....	92
Enable or disable the e-shredding function.....	93
Select the e-shredding algorithm.....	94
Specify the number of overwrite passes.....	95
Remote security.....	96
Generate a certificate request.....	97
Import a CA-signed certificate: Import the root certificate	99
Import a CA-signed certificate: Import the intermediate certificate.....	100
Import a CA-signed certificate.....	101
Import a CA-signed certificate: Check and import the root certificate.....	102
Find information about the Identity Certificate.....	103
Configure the presets.....	104
What you need to know about presets	104
Set the default copy preset	105
Configure the custom copy preset	106
Set the default print preset	107
Configure the custom print preset	108
Make a custom preset available on the user panel.....	109
Configure the templates.....	110
Fold and Scan templates	110
Create a new template.....	111
Delete all templates.....	112
Export templates.....	113
Import templates.....	114
Restore the factory defaults of the templates.....	115
Enable or disable scan templates.....	116
Configure the locations.....	117
Configure your locations.....	117
Enable or disable USB.....	118
Enable and edit the Home folder.....	119
Enable PlanWell Collaborate (optional).....	120
Create an external location.....	121
Set a default external location	123
Set a default print destination.....	124
Troubleshoot the creation of an FTP external location (after an error message).....	125
Troubleshoot the creation of an SMB external location (after an error message).....	128

Troubleshoot the creation of a WebDAV external location (after an error message).....	130
Configure the printer settings.....	131
Configure the regional settings	131
Configure the user session time-out.....	132
Configure the working hours.....	133
Configure the energy save modes	134
Configure the media request time-out	135
Configure the core size of the media rolls	136
Configure the pen settings.....	137
Configure the roll-to-roll mode in WebTools Express.....	138
Configure the finishing settings.....	139
Set the Finishing Assistant	139
Fold settings for custom fold templates.....	140
Fold settings for embedded fold templates.....	143
Default fold templates.....	144
Adjust the print quality and print productivity.....	145
Set the print quality.....	145
Set the long plot mode.....	146
Set the automatic roll switch.....	147
Set the spool threshold.....	148
Set the rotation mode.....	149
Set the alignment mode	150
Set the PDF render engine.....	151
Set transparency flattening for PDF.....	152
Set the Print Assistant behavior	153
Optimize the print productivity.....	154
About color management.....	155
What is color management?.....	155
What is an input profile / standardization?	156
What is color feel?.....	159
What are rendering intents?.....	160
Definition of rendering intents.....	160
Rendering intent: Perceptual (photo)	161
Rendering intent: Saturation (business graphics).....	162
Rendering intent: Relative colorimetric	163
Rendering intent: Absolute colorimetric.....	164
What is an output profile?.....	165
Color management settings in WebTools Express.....	166
Color management settings and job submission	167
Priorities in the color management settings	169
Color management settings for HP-GL, HP-GL/2 and HP-RTL files.....	171
Color management settings for TIFF and JPEG files (RGB input).....	172
Color management settings for TIFF and JPEG files (CMYK input).....	173
Color management settings for PostScript files (RGB input)	174
Color management settings for PostScript and PDF files (CMYK input).....	175
Color management settings for PDF files (RGB input)	176
Color management settings for PDF files (CMYK input).....	177
Color management settings for PDF files (Gray input).....	178
Manage media.....	179
What is a media profile?	179
Configure the media profiles	180
Install a media profile	181
Create a custom media size.....	182
Configure the media sizes.....	183
Configure mobile printing and scanning.....	184
Publisher Express.....	184
Configure WebTools Express settings for a mobile connection.....	186
Generate the Quick Response Card.....	187
Connect your mobile device to Publisher Express	188

Chapter 4

Use the printing system.....	189
How to feed an original.....	190
How to auto-feed an original.....	191
How to cut the media in roll-to-roll mode.....	192
Print Jobs - Job submission tools.....	193
Use Publisher Express to send a print job.....	193
Use the Smart Inbox to send a print job.....	195
Use Publisher Select 3 to send a print job.....	196
Use Driver Select for Microsoft® Windows® to send a print job.....	198
Use the Driver Express for Adobe® Postscript® 3™ to send a print job.....	200
Use Publisher Mobile to send a print job.....	201
Print from your mobile device.....	203
Use FTP to send a print job.....	205
Use LPR to send a print job.....	206
Use the cloud to send a print job.....	207
Use the home folder to send a print job.....	208
Troubleshoot print job submission.....	209
Print Jobs.....	210
Do a default print job	210
Direct print	212
Print from a USB key.....	213
Print presets on the user panel.....	214
The Image preset for print jobs.....	215
Advanced settings for print jobs.....	216
Copy Jobs.....	221
Do a default copy job	221
Copy presets on the user panel.....	222
The Image preset for copy jobs.....	223
Advanced settings for copy jobs.....	224
Recommended settings for copy jobs.....	234
The original type.....	236
Make a half size copy.....	238
Make a copy and add a strip.....	239
Make a copy and remove a strip.....	240
Make a copy of a specific area of an original.....	241
Make a copy and remove a specific area of an original.....	242
Make a copy and scale to another size.....	243
Make a copy of a dark original (Diazo).....	244
Make a copy of an original with highlighted colors.....	245
Copy by set.....	246
Scan Jobs.....	247
Do a default scan job	247
Scan templates on the user panel.....	248
Advanced settings for scan jobs.....	249
Advised settings for scan jobs.....	255
The original type.....	257
File type.....	259
Make a scan and remove a strip.....	261
Scan to a USB key.....	262
Scan to the home folder.....	263
Save a scanned document on your mobile device.....	264
Pause, resume, or stop an active job.....	265
Clear the system.....	266

Chapter 5

Maintain the printing system.....	267
Update your system.....	268

Update the software.....	268
Update the system software on the user panel.....	269
Update the system software in WebTools Express.....	270
Install the system security patches in WebTools Express.....	271
Replace the media.....	272
The media drawer	272
Remove a media roll.....	273
Unpack a media roll.....	277
Load a media roll.....	279
Media types.....	283
Media sizes.....	285
Refill the toner.....	287
Replace the toner cartridge	287
Replace the maintenance tray	290
Maintain the scanner.....	294
Clean the scanner.....	294
Calibrate the scanner.....	297

Chapter 6

License management.....	299
Introduction to license management.....	300
Check your licenses.....	301
Save the currently active licenses	302
Get a new license file.....	303
Activate a new license.....	304

Chapter 7

Account management.....	305
Introduction to account management.....	306
Enable account management in WebTools Express.....	307
An overview of Océ Account Center.....	308
Océ Account Console ®.....	309
Introduction to Océ Account Console.....	309
Summary of Océ Account Console.....	310
Accounting workflow.....	312
Workflow on the printer.....	312

Chapter 8

Solve problems.....	313
How to solve problems with jobs.....	314
Clean the print surface.....	315
Clear an original jam in the scanner.....	319
Disconnect the network cable and the mains supply cable.....	320
Event messages.....	322
Settings in case of errors.....	325
Print a demo print.....	326
Print a test print.....	327

Chapter 9

Support.....	329
Counter history.....	330
Audit log.....	331
Remote Service: configure the proxy.....	332
Remote Service: check the connection.....	333
Remote Service: allow remote assistance.....	334
Downloads and support for your product.....	335

Index.....337

Chapter 1

Introduction

About the ColorWave 3600

Introduction

The ColorWave 3600 is a wide format TonerPearl printer that uses the patented CrystalPoint technology.

Illustration



The main components of the ColorWave 3600 printing system

Component	Description / Function
The ColorWave 3600	The ColorWave 3600 creates the printed output. With the integrated Scanner Express (optional) you can also perform copy and scan jobs. Use the ClearConnect multi-touch user panel to easily configure and submit your jobs.
WebTools Express	WebTools Express provide multiple users a remote view on the system and control on the system's workflow, without any need to install software. The [System administrator] or the [Key operator] can also use WebTools Express to configure the system and fine-tune the system to optimally fit the customer's company workflow and processes.

About the users

Introduction

The settings in WebTools Express can be configured and managed to enable the optimal performance of the ColorWave 3600.

You can view all the settings in WebTools Express but when you want to change the value of a setting, a message appears. This message indicates that the setting is password protected. You must log in with a password to change a setting.



IMPORTANT

Handle and store all passwords securely and with care. In case of forgotten passwords, a service technician can reset the passwords only when his rights have been enabled ([Security] - [Configuration] - [Permissions for Service] - [Allow Service technician to reset passwords]). Otherwise the system software has to be reinstalled.



NOTE

You do not need a password for daily use of the system.

Overview of user roles and authorizations

The table below displays the different user roles and the authorizations that belong to the role.

User role	Description
[Key operator]	Besides the normal use of the system, the Key operator takes care of the daily maintenance. To change the value of specific Key operator settings in WebTools Express you must log in as a Key operator.
[System administrator]	The System administrator takes care of the integration of the system into the IT-infrastructure of the customer. To change the value of specific System administrator settings in WebTools Express you must log in as a System administrator.
[Power user]	The Power user is authorized to access all functionality of WebTools Express except the Service settings.

The [service] role is mainly used for the printer installation and to configure the Service settings.

Notes for the reader

Typography





This manual uses the following typography to indicate elements that are part of the user interface.



Typography	Indicates
[Text between square brackets]	Name of a button, tile, setting, value, or other option of the user interface
<Text between angle brackets>	<ul style="list-style-type: none"> Name of a key on a keyboard Name of a variable: item that varies according to the context
Text displayed in courier font	<ul style="list-style-type: none"> File path Command Prompt comment
[Text] →[displayed in] →[menucascade]	Names of options to be used in a fixed order

Safety symbols

Before you use this product, make sure you read and understand the safety information that belongs to the product. Find the safety information on "<http://downloads.cpp.canon>". Also be sure to follow all warnings and instructions marked on the product.





This manual uses the following safety symbols to indicate hazards and precautions.

Symbol	Type of symbol	Indicates
	WARNING	Indicates a warning concerning operations that may lead to death or injury to persons if not performed correctly. To use the machine safely, always pay attention to these warnings.
	CAUTION	Indicates a caution concerning operations that may lead to injury to persons if not performed correctly. To use the machine safely, always pay attention to these cautions. This indication can concern hazards that have a specific CAUTION symbol. The 'hot surface', 'electric shock', 'moving parts' and 'laser beam' cautions are listed below.
	CAUTION	Hot surface Indicates a caution concerning operations that may lead to injury to persons if not performed correctly. To use the machine safely, always pay attention to these cautions.
	CAUTION	Electric shock Indicates a caution concerning operations that may lead to injury to persons if not performed correctly. To use the machine safely, always pay attention to these cautions.
	CAUTION	Moving parts Indicates a caution concerning operations that may lead to injury to persons if not performed correctly. To use the machine safely, always pay attention to these cautions.

Symbol	Type of symbol	Indicates
	CAUTION	Laser beam Indicates a caution concerning operations that may lead to injury to persons if not performed correctly. To use the machine safely, always pay attention to these cautions.
	IMPORTANT	Indicates an operational requirement or restriction. Read these items carefully in order to prevent damage to equipment, software, data, media, or property.
	NOTE	Indicates a clarification of an operation or contains additional explanations for a procedure. Reading these notes is highly recommended.

Body protection symbols

This manual uses the following body protection symbols to indicate that it is important to protect yourself before performing a specific task or action.

Symbol	Type of symbol	Indicates
	IMPORTANT	Hand protection Wear the mentioned type of gloves when you perform this task or action.
	IMPORTANT	Eye protection Use the mentioned type of eye protection when you perform this task or action.
	IMPORTANT	Body protection Wear the mentioned type of body protection when you perform this task or action.
	IMPORTANT	Foot protection Wear the mentioned type of safety footwear when you perform this task or action.

Available documentation

Introduction

This manual is part of a complete documentation set. The following table shows a complete overview of the available documentation.



NOTE

For up-to-date documentation, visit the downloads page on the Internet and find all the information for your printer.

Available documentation

Documentation	Availability
User Manual - Operation guide	<ul style="list-style-type: none"> On the download website under the product name ("http://downloads.cpp.canon"). Available as a PDF file in multiple languages.
Online Help - WebTools Express	<ul style="list-style-type: none"> Accessible from the application. Available in multiple languages.
User manual - Safety guide	<ul style="list-style-type: none"> On the download website under the product name ("http://downloads.cpp.canon"). Available as a PDF file in multiple languages.
ColorWave-PlotWave Connectivity Manual for Windows - Administration guide	<ul style="list-style-type: none"> On the download website under the product name ("http://downloads.cpp.canon"). Available as a PDF file in English only.
PlotWave-ColorWave Systems Security - Administration guide	<ul style="list-style-type: none"> On the download website under the product name ("http://downloads.cpp.canon"). Available as a PDF file in English only.

Available documentation Driver Select for Microsoft® Windows®

Documentation	Availability
User guide	<ul style="list-style-type: none"> On the download website under the product name ("http://downloads.cpp.canon"). Available as a PDF file in multiple languages.
Online Help	<ul style="list-style-type: none"> Embedded in the application. Available in multiple languages.

Available documentation Driver Express for Adobe® Postscript® 3™

Documentation	Availability
Installation guide	<ul style="list-style-type: none"> On the download website under the product name ("http://downloads.cpp.canon"). Available as a PDF file in multiple languages.
Online Help	<ul style="list-style-type: none"> Embedded in the application. Available in multiple languages.

Available documentation Publisher Select 3

Documentation	Availability
User guide	<ul style="list-style-type: none">• On the download website under the product name ("http://downloads.cpp.canon"). Available as a PDF file in multiple languages.
Online Help	<ul style="list-style-type: none">• Accessible from the application. Available in multiple languages.

Chapter 2

Get to know the printing system

The hardware

The components of the printer (front)

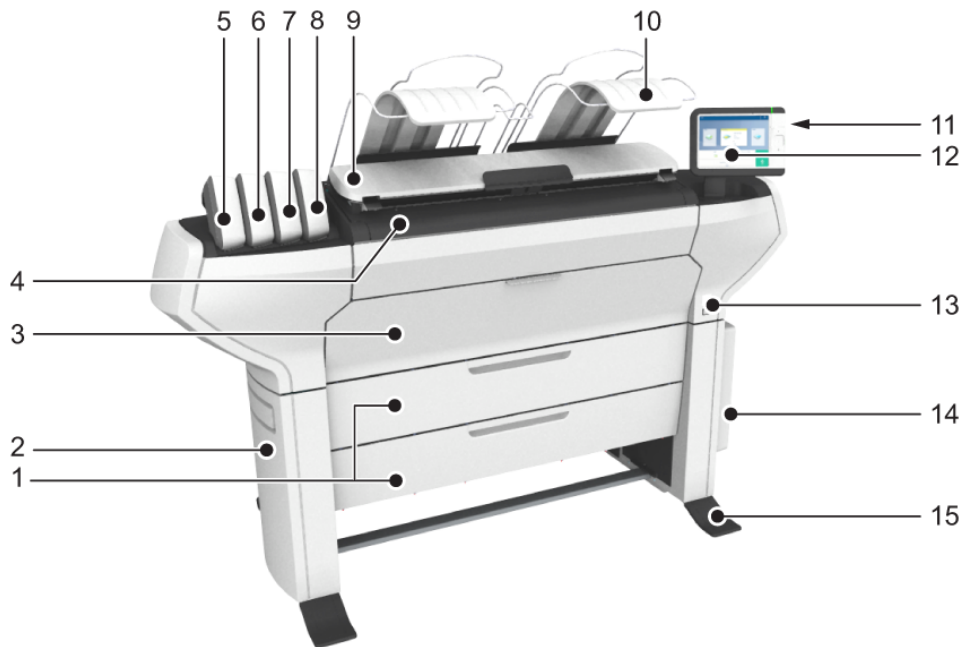

Component - function table

No	Component	Description / Function
1	[media drawers]	Media drawers with 2 media rolls
2	[lower left side cover]	Cover at the bottom left of the device
3	[lower front cover]	Door to access the media path
4	[top cover]	Component that covers the top surface of the device
5	[toner cartridge (cyan)]	Toner cassette for cyan TonerPearls®
6	[toner cartridge (yellow)]	Toner cassette for yellow TonerPearls®
7	[toner cartridge (black)]	Toner cassette for black TonerPearls®
8	[toner cartridge (magenta)]	Toner cassette for magenta TonerPearls®
9	[transparent top cover]	Door to access the print surface / media output section
10	[top delivery tray]	Delivery tray that collects the printed output
11	[USB port]	USB connector to use a USB key to print from or to scan to

No	Component	Description / Function
12	ClearConnect: multi-touch [user panel]	The ClearConnect user panel allows the user to start copy, scan, or print jobs, and to monitor the system and the job status.
13	[on/off button]	Button to start or shut down the printer. This button is equivalent to the [Shut down] button in WebTools Express.
14	[lower right side cover]	Component that covers the controller
15	[foot]	Component at the bottom of the printer, used to level it

The components of the printer (back)

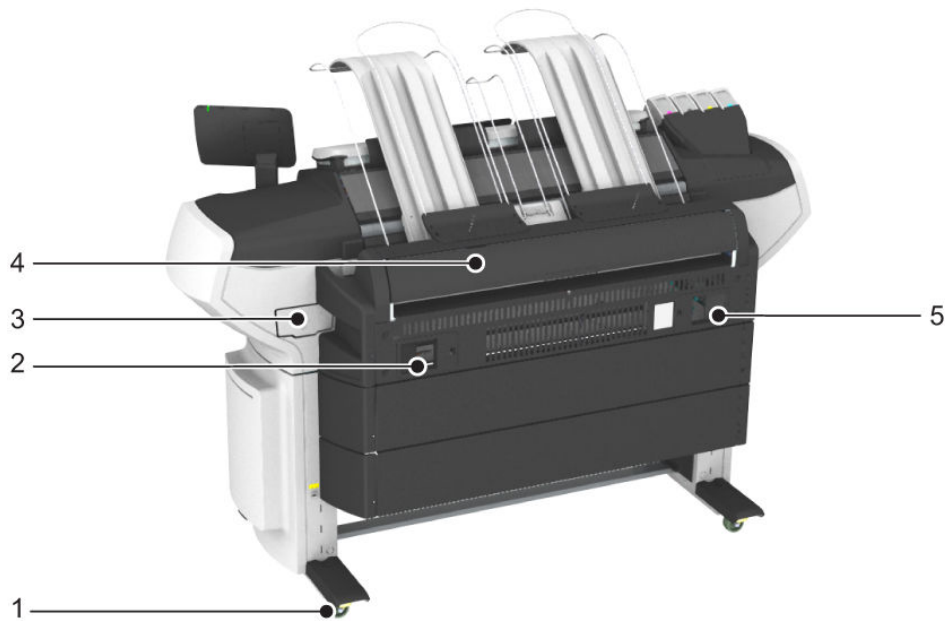

Component - function table

No	Component	Description / Function
1	[wheel]	Swivel wheel with brakes
2	[folder connection panel]	Component to connect the folding device to
3	[maintenance tray drawer]	
4	[upper back cover]	Cover at the back of the device, used to access the machine for error recovery
5	[power switch]	Switch the main power supply on or off You can find the serial number of the printer on the sticker above the power switch

The media drawer

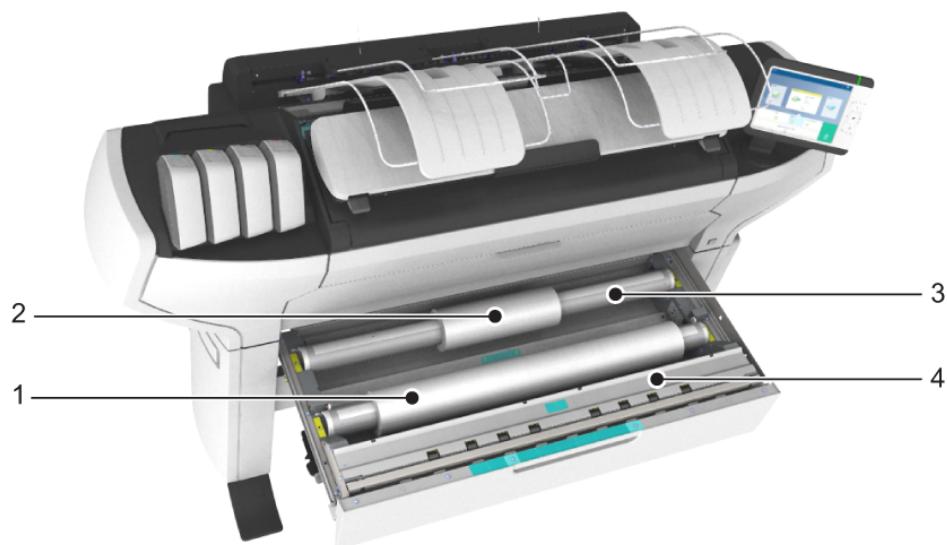

Component - function table



IMPORTANT

Only use intact media rolls. Dented media rolls can damage the [Imaging devices].

No	Component	Description / Function
1	[media roll] 1	Media placed on roll holder in first position.
2	[media roll] 2	Media placed on roll holder in second position.
3	[roll holder]	Carries the media roll.
4	[roll loading station]	Groove integrated behind the front cover of the media drawer.

ClearConnect user panel

Introduction

The ClearConnect is the multi-touch user panel of the printer.



No.	Component	Function
1.	[status light]	Light that gives feedback on the status of the printer. <ul style="list-style-type: none"> • A green light indicates that the printer is scanning or printing. • A green blinking light indicates that the printer is in a transition state (start-up, shut-down, pause). • A red light indicates that an error occurred or the print queue is paused. • When the light is off the system is ready or shutdown.
2.	[wake-up button]	Button to: <ul style="list-style-type: none"> • Get the printer out of sleep mode. • Wake the printer up to full functionality.
3.	[USB port]	Insert a USB key to: <ul style="list-style-type: none"> • Print a file directly from the USB key. • Save a scan file directly on the USB key. The port green light starts to blink during data transfer.
4.	[stop button]	Button, with a red light, to: <ul style="list-style-type: none"> • Immediately interrupt a scan job. • Stop a print job after the page that is being printed.
5.	[home button]	Button to: <ul style="list-style-type: none"> • Return to the user panel home screen. • Reset settings to default by pressing the button twice.

No.	Component	Function
6.	[green button] (touch)	Dynamic tile on the user panel display to: <ul style="list-style-type: none">• Start a scan job, a print job or a copy job on the user panel.

The components of the scanner (optional)

Introduction

The embedded scanner is an optional of the printer.

The components of the scanner (top cover closed)



	Component	Description / Function
1	[top cover]	Closes off the scanner.
2	[output refeed protector]	Prevents that your output is refeed into the scanner.
3	[originals exit]	Exit for the scanned original.
4	[original feeding table]	Use the original feeding table to feed the original into the scanner (face up).
5	[open levers]	Use the open levers to open the top cover of the scanner.

The components of the scanner (top cover opened)

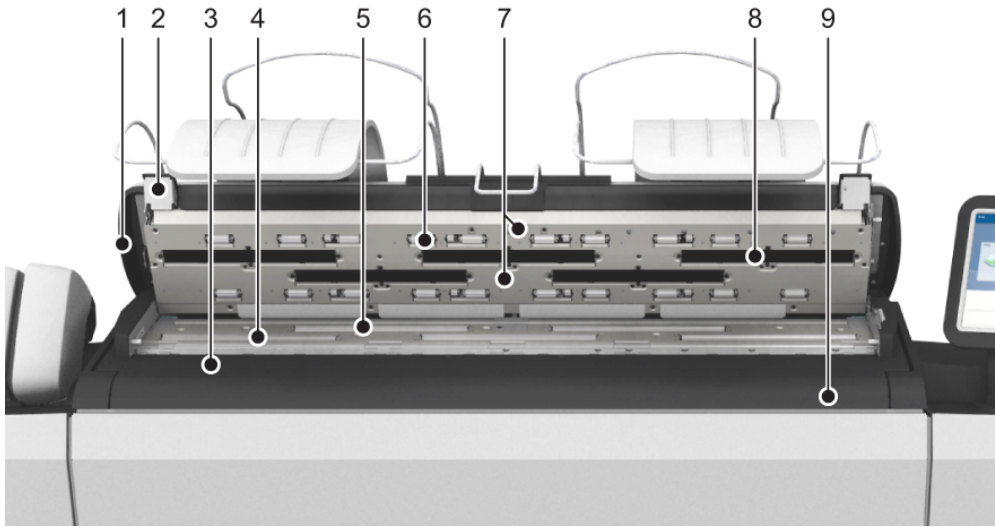

	Component	Description / Function
1	[top cover]	Closes off the scanner.
2	[open levers]	Use the open levers to open the top cover of the scanner.
3	[original size ruler]	Use this ruler to measure the original.
4	[original feed rollers]	A set of rollers used to transport the original.
5	[original support rollers]	A set of rollers to guide the original.
6	[scanner top cover rollers]	A set of rollers in the top cover to guide the original.
7	[original sensors]	Sensors to detect the original.
8	[transparent contact plates]	Cover of the image sensors.
9	[original feeding table]	Use the original feeding table to feed the original into the scanner (face up).

The delivery destination

Introduction

The ColorWave 3600 is delivered with a [Top Delivery Tray (TDT)] to collect your printed output.

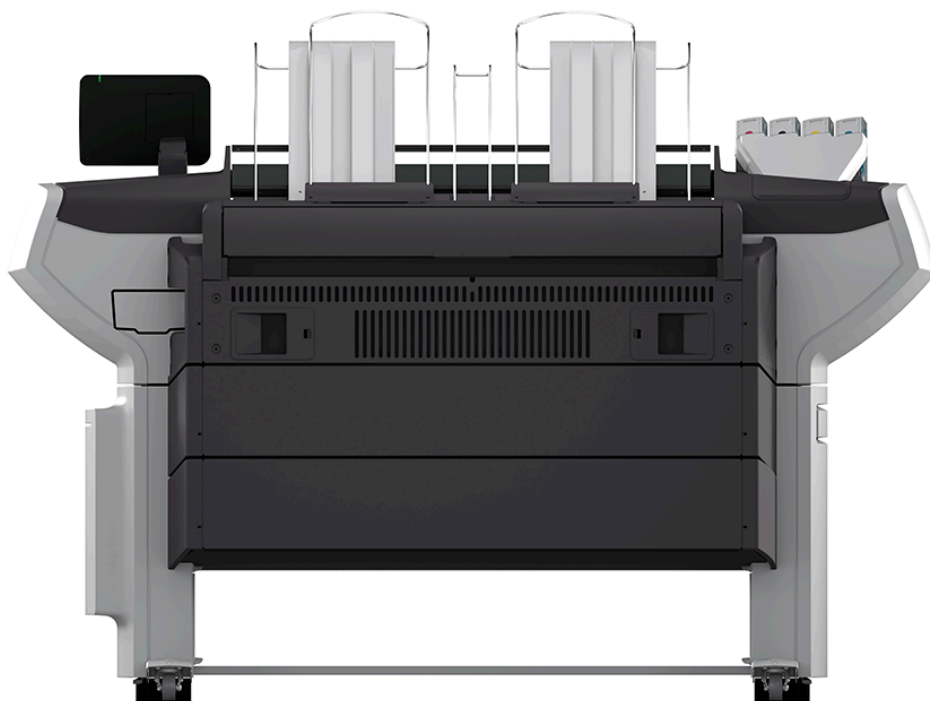







The [Top Delivery Tray (TDT)] can collect 50 - 100 plain paper prints with a maximum length of 1200 mm, 48 inch. The media type you use influences the output capacity.



In WebTools Express you can define the default [Print delivery] for your printed output. To set the default [Print delivery], select the [Preferences] - [Print job defaults] tab.

- If you use 2 inch media cores instead of the standard 3 inch media cores, the printed output is automatically delivered at the back of the printer. The installation of one of the finishing options is then advised.
- Some media require a specific output delivery. For example heavy media or media that requires a manual cut can automatically be delivered at the back of the printer. This is defined in the properties of the media type.
- If you select [Top Delivery Tray (TDT)] your printed output is by default delivered in the standard [Top Delivery Tray (TDT)].
- If you select [Back output] your printed output is by default delivered at the back of the printer. In that case you can expand your printer with one of the following finishing options.

The finishing options

See also [Select the finishing device configuration on page 28](#)

[Receiving rack (basket)]	Illustration
<p>The [Receiving rack (basket)] is hooked at the rear side of the printer. It can collect 2 - 5 prints. The [Receiving rack (basket)] bends the printed output. Not all media types are appropriate for this finishing option.</p> <p> NOTE The [Receiving rack (basket)] is not supported in combination with the folding device, take-up module or Stacker Select.</p>	
Folding device	Illustration
<p>The folding device is an automatic folding device that folds large sized plots.</p> <p> NOTE</p> <ul style="list-style-type: none"> The folding device is not supported in combination with the [Receiving rack (basket)], take-up module or Stacker Select. 	
Stacker Select	Illustration
<p>The Stacker Select is a flat tray behind the printer. The stacker can collect a maximum of 400 D-size/A1 prints (75 grams).</p> <p> NOTE The Stacker Select is not supported in combination with the [Receiving rack (basket)], folding device or take-up module.</p> <p> NOTE A technician is required to install the Stacker Select and configure the system.</p> <p>For the Stacker Select documentation is available on the download website ("http://downloads.cpp.canon/").</p>	

Take-up module (TUM) / Roll Wind module (RWM)	Illustration
<p>The take-up module and the Roll Wind module enable you to wind up your print job on a roll without cutting. This can be handy when you want to transport your prints or want to finish your prints at a later time. When your machine is equipped with the take-up module or the Roll Wind module, you must first put the machine into the roll-to-roll mode. You can enable the roll-to-roll mode in WebTools Express and on the user panel.</p> <p> NOTE The take-up module and the Roll Wind module are not supported in combination with the [Receiving rack (basket)], folding device or Stacker Select.</p> <p>See The take-up module (optional) and the Roll Wind module (optional) on page 31, Configure the roll-to-roll mode in WebTools Express on page 138 and Configure the roll-to-roll mode on page 31</p>	

Select the finishing device configuration

When to do

On the user panel, you can choose the type of the finishing device. The default value is [No finisher].

Procedure

1. Tap on the system menu thumbnail in the dynamic bar. The system menu opens.
2. Tap on [Finishing device] in the list in the right part of the display.
3. Log in as a Key operator.
A wizard opens.
4. Follow the steps in the wizard.

Result

After you have followed the steps, restart the system to apply the configuration.

The Scanner Professional (optional)

Introduction

The printer can be delivered with a stand-alone scanner, the Scanner Professional.



NOTE

- A technician is required to install the scanner and to configure the system.
- For more information, visit "<http://downloads.cpp.canon>" and select your product.

The folding device (optional)

Introduction

The printer can be delivered with an external folding device. The ColorWave 3600 is compatible with the Folder Express 3011 and the Folder Professional 6011/6013.



NOTE

- A technician is required to install the folding device and to configure the system.
- After installation you have to log in as a Key operator to change the type of the finishing device.
- For more information on folding devices, visit "<http://downloads.cpp.canon>" and select your product.

Media compatibility with the folding device

The following media are compatible with the folding device:

- Plain papers: 60- 110 g
- Vellum, Translucent and Tyvek: fold quality depends on used media

The take-up module (optional) and the Roll Wind module (optional)

Introduction

The ColorWave 3600 is compatible with the optional take-up module and Roll Wind module.

The take-up module and the Roll Wind module allow the user to print in roll-to-roll mode. The module rolls up your print jobs automatically on a core without cutting. This can be handy when you want to transport your prints or want to automatically clean-cut or trim your prints, laminate or mount an adhesive back to the prints.

Before you can use the take-up module, you must first set the printer into the roll-to-roll mode. You can enable the roll-to-roll mode in WebTools Express and on the user panel, see [Configure the roll-to-roll mode in WebTools Express on page 138](#) and [Configure the roll-to-roll mode on page 31](#).

By default, the printer is delivered in roll-to-sheet mode. In this mode, the machine cuts and delivers each print to the selected delivery destination.

Configure the roll-to-roll mode

Introduction

When you want to use the take-up unit, your printer has to be in the roll-to-roll mode. When you enable the roll-to-roll mode, the printer will not cut between pages. You can also configure the roll-to-roll mode in WebTools Express.



NOTE

- When the roll-to-roll mode is enabled, each print job is delivered to the [Back output]; even when you set the [Top delivery tray] as output location for your prints.
- To calibrate the printer the roll-to-roll mode must be disabled.
- When the printer is in roll-to-roll mode, you have to cut the media before you can replace a toner cartridge.

Procedure

1. Tap on the system menu thumbnail. The system menu opens.
2. Tap on [Roll-to-roll option] in the list in the right part of the display.
3. Log in as a Key operator.
4. Select [Roll-to-roll disabled] or [Roll-to-roll enabled].
5. Tap [Ok] to confirm, or [Cancel] to reject your entries.

The earthquake provision

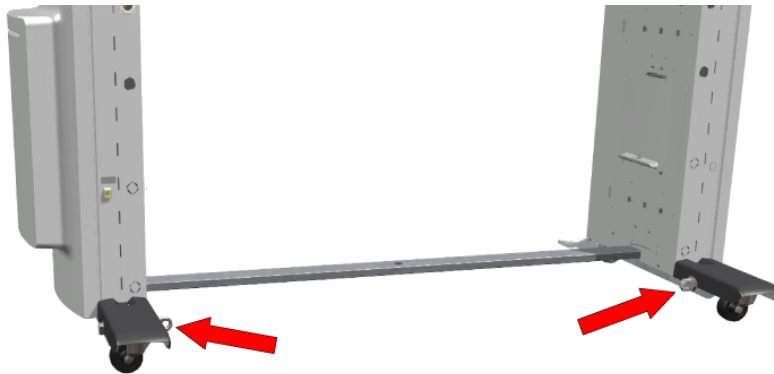

Free-standing printers can move during an earthquake, injuring people or blocking an exit. With the delivered earthquake protection rings you can fix the printer to the building to safely secure the printer on its original place.

These rings can be mounted during installation of the printer.

Connect your printing system

Printer working area (Footprint)

The ColorWave 3600 requires a floor space / working area of at least 3100 mm x 2260 mm, or 122 inch x 89 inch.

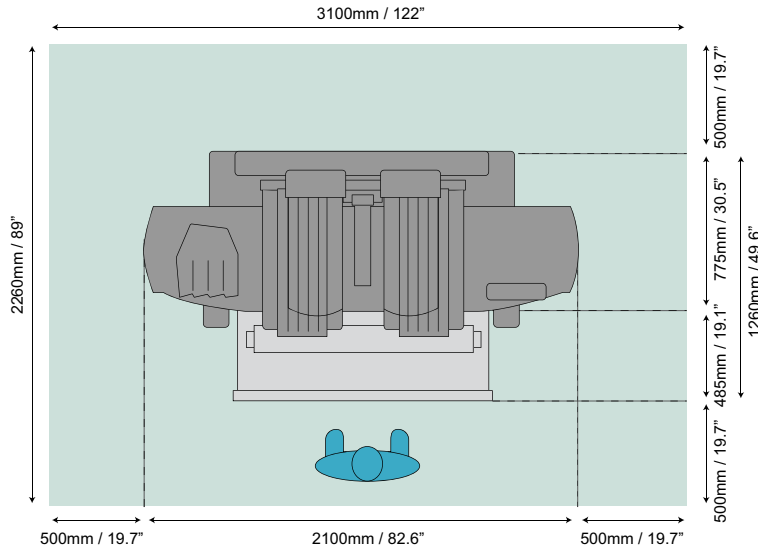

Connect the mains supply cable and the network cable

Procedure



IMPORTANT

Make sure the power switch [A] is in 'off' position.

1. Lift the protection cover up [B].

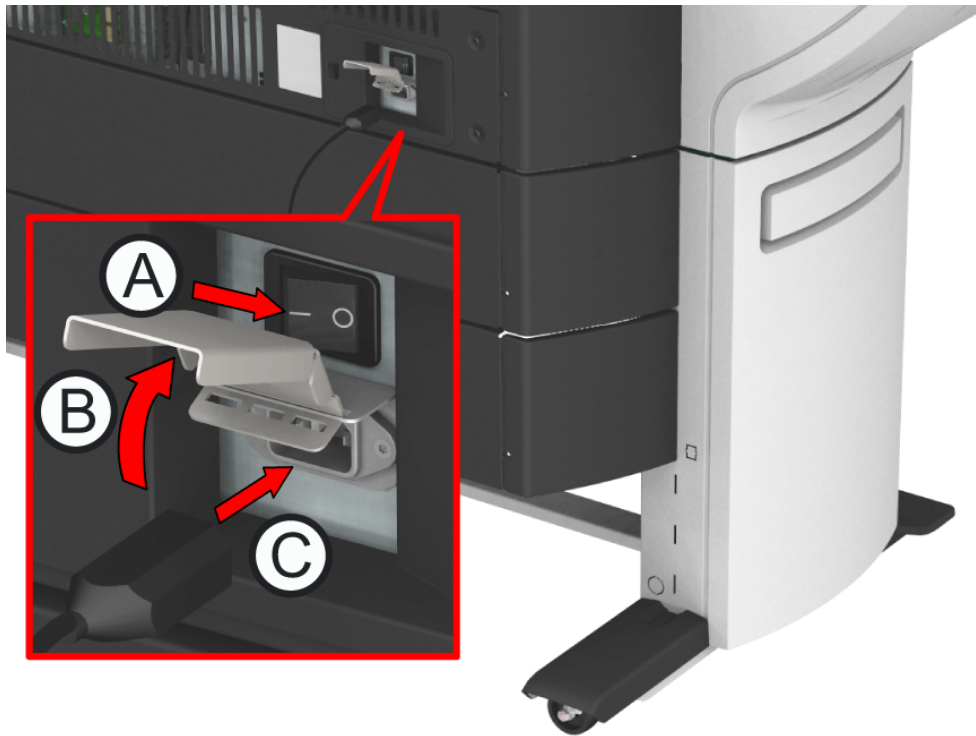

2. Plug the mains supply cable into the power connection at the back of the printer [C].
3. Plug the other side of the mains supply cable into the wall socket.
4. Make sure one end of the network cable is connected to your company network.

5. Plug the other end of the network cable into the network connection at the left back of the printer [D] , to connect the printer to your company network.

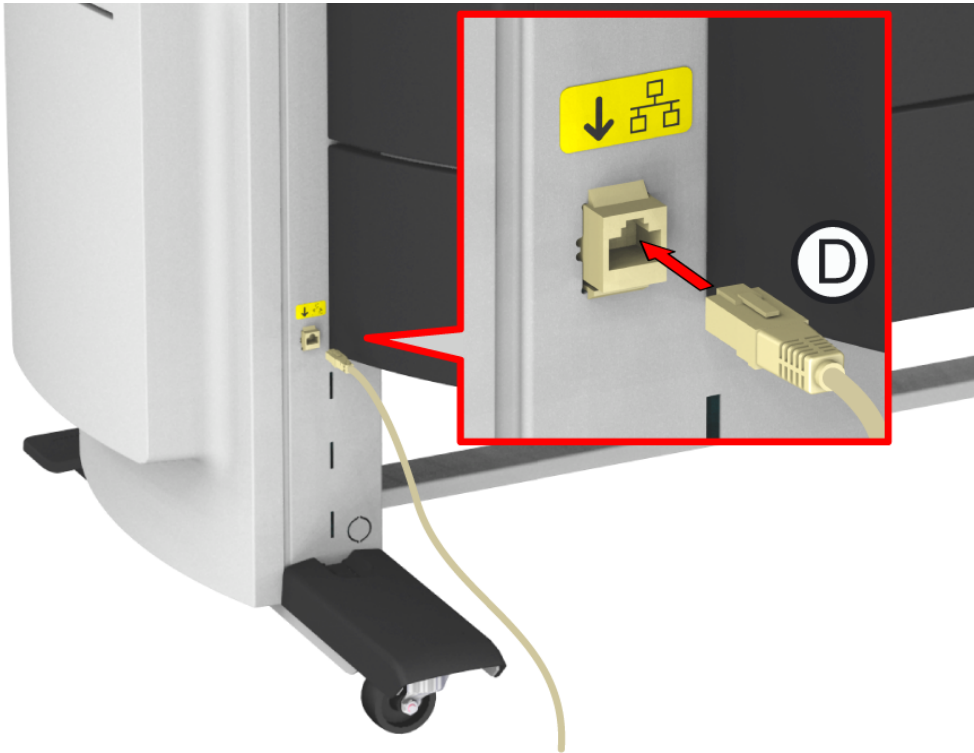

Switch on the printing system



IMPORTANT

- Make sure the mains supply cable is plugged in.
- Make sure the network cable is plugged in.

For more information, see [Connect the mains supply cable and the network cable on page 34](#)

Procedure

1. Switch on the power switch at the back of the printer.

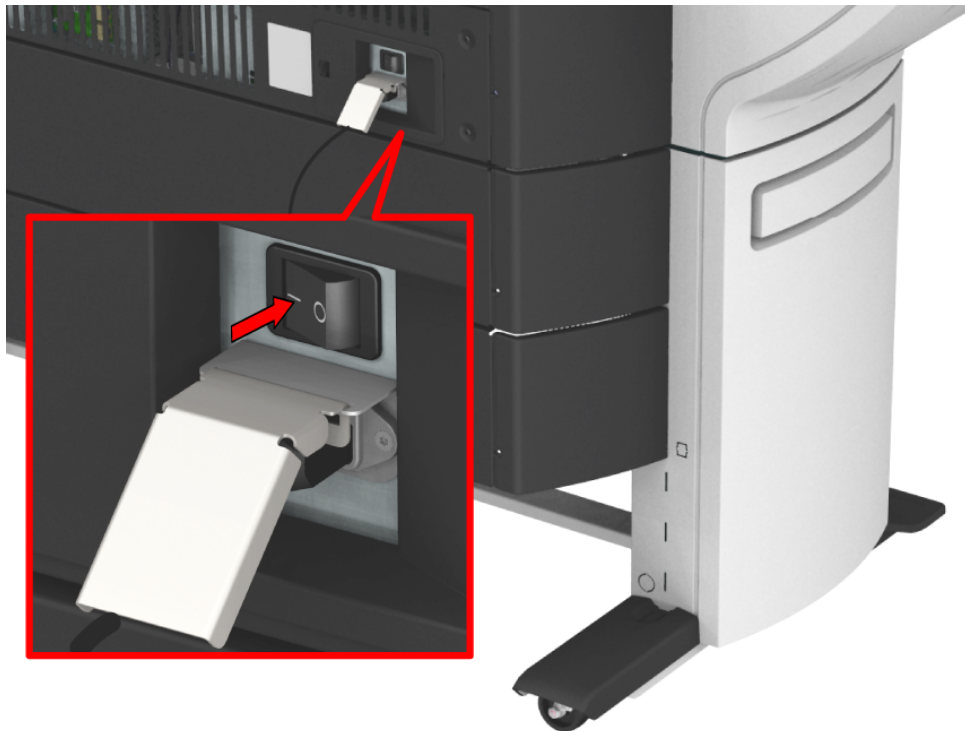

2. Press the on/off button at the front of the printer to start the system.



Turn off the printing system

Introduction

When you want to switch off the printing system completely, you have to take a few steps.

Procedure

1. Press the on/off button at the front of the printer to switch the printing system off.



NOTE

You can also use the [Shut down] button in WebTools Express.



IMPORTANT

Wait until the on/off button stops blinking.

2. Switch off the power switch at the back of the printing system.

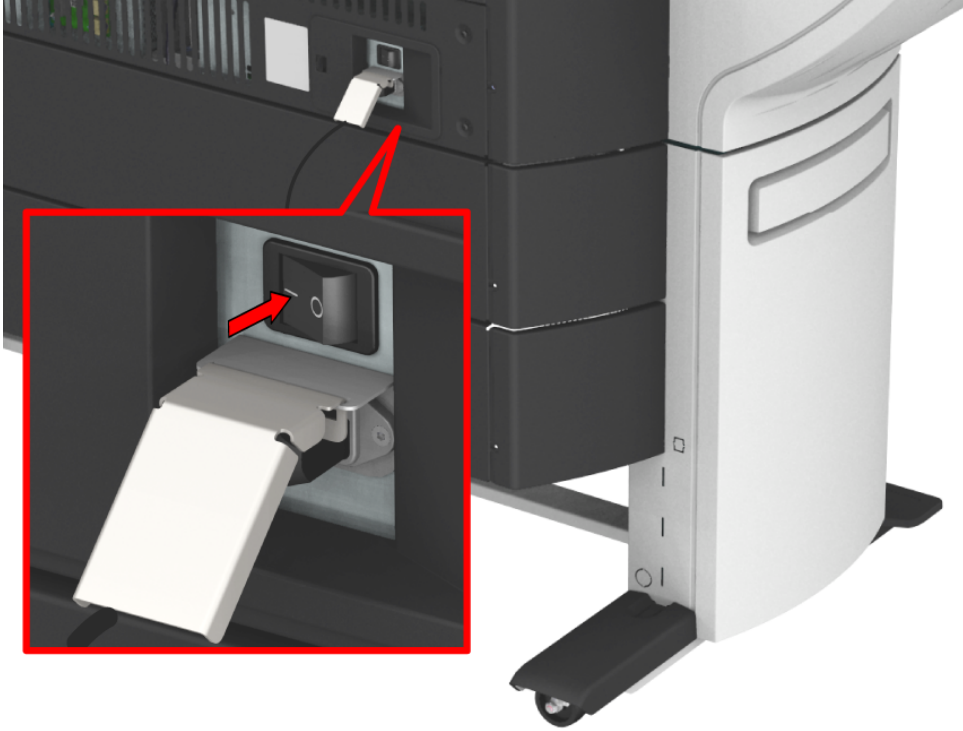

Move the system

Introduction

You can move the printer to a new location.

Before you begin



IMPORTANT

- When the printer is connected, you must first switch off and disconnect the printer (see [Switch the printing system off on page 38](#) and [Disconnect the network cable and the mains supply cable on page 320](#)).
- Close the media drawers.



NOTE

Be aware of the size of the printer working area (see [Printer working area \(Footprint\) on page 33](#)).

Procedure

1. Pull with both hands to remove the left side cover.



2. Pull at the left foot cover to remove it.

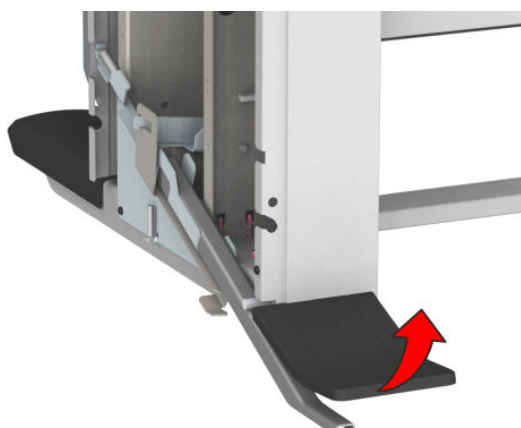

3. Push the handle [1]. The foot snaps up [2].

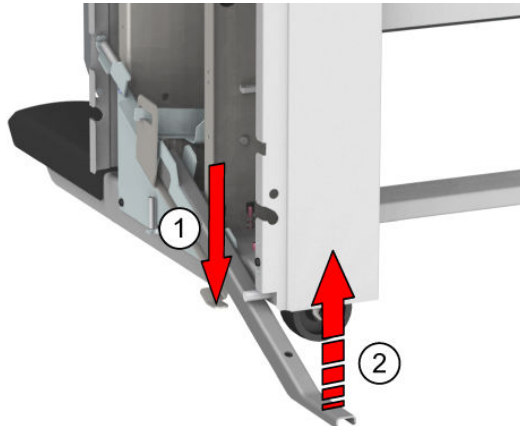

4. Repeat action 1 till 3 on the right side cover.
5. Move the printer to the preferred location. Be aware of the printer working area.
6. Pull out the left foot [1] until it touches the ground and locks [2]. You should hear a click when it locks into place.

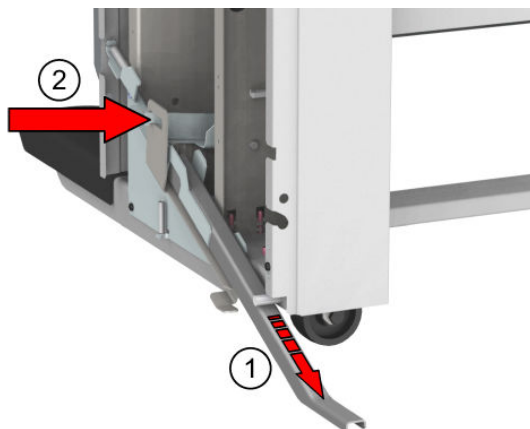
**NOTE**

If you do not hear a click, place your foot on the foot of the printer [1] and at the same time push gently against the printer until you hear the click.

7. Place the foot cover. Place the pin into the notch.

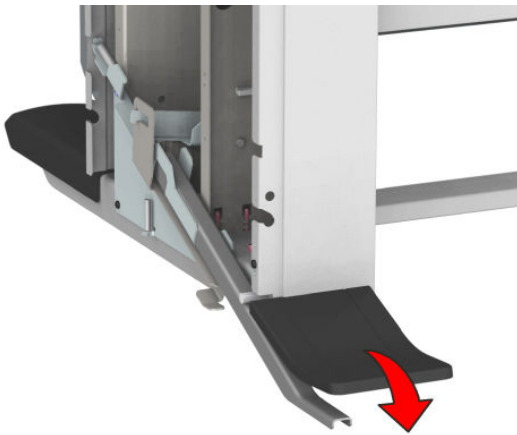
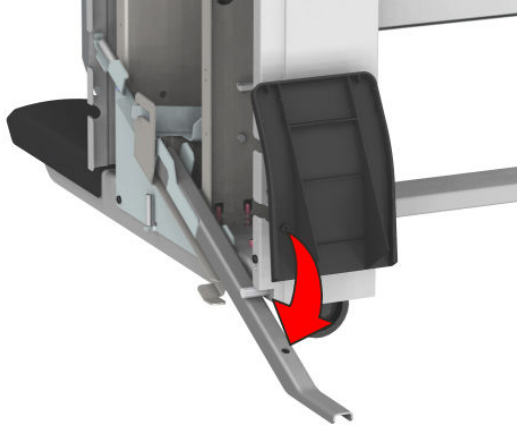

8. Place the pin into the notch to mount the left side cover.
Pin:

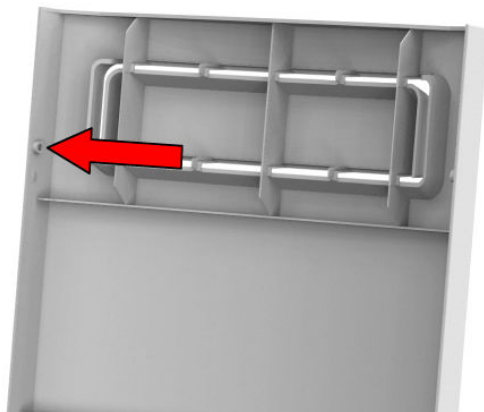

Notch:

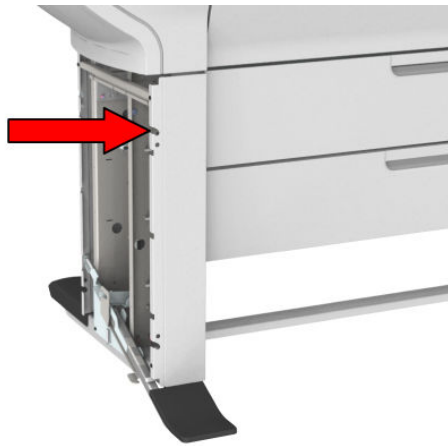

9. Push the cover into place.



10. Repeat action 6 till 9 for the right side cover.

Workflow of the ClearConnect user panel

The home screen

Introduction

The default screen of the ClearConnect user panel is the home screen.

From the home screen you can manage jobs and enter the system menu.

The home screen



No.	Component	Function
1.	dynamic bar and [active job]	In the dynamic bar you can see the system states (warming-up, cleaning etc.) and the active job when present. <ul style="list-style-type: none"> • When you tap the active job the job queue appears with the list of waiting jobs. • When you tap the active job the pause tile appears, with which you can pause the printing process.
2.	[system menu]	In the dynamic bar you can access the system menu. <ul style="list-style-type: none"> • When you tap the system menu thumbnail, a new window opens with a dynamic view of the system and printer setup settings.

No.	Component	Function
3.	[Copy tile] [Scan tile] [Print tile]	<p>These dynamic tiles help you to perform copy, scan and print jobs. Select the correct tile for your job:</p> <ul style="list-style-type: none"> • When you tap one of the tiles and then use the Smart Access, you can start your job immediately. • As default the print tile is selected, but when you insert an original into the scanner the copy tile is selected. When you insert an original and a USB key the scan tile is selected. • When you want to make more settings you can tap the tile twice, and a new window with presets or settings opens.
4.	Smart Access	The dynamic Smart Access changes specifically for a print, copy or scan job and helps you to quickly start a job.
5.	[live scan view]	<p>The live scan view appears in the Smart Access. The view shows the width and alignment of your document while it slides through the Smart Access.</p>
6.	[green button]	<p>The green button is dynamic and appears on all screens in the bottom right corner of the display.</p> <ul style="list-style-type: none"> • When the button is green, the printer is ready to process your job. • When the button is gray, the printer is not ready to process your job.

The job queue and the system menu

Introduction

The dynamic bar is located in the upper part of the home screen on the user panel display. The dynamic bar consists of the job status with the job queue, the printer status, and the system menu.

The active job and the job queue

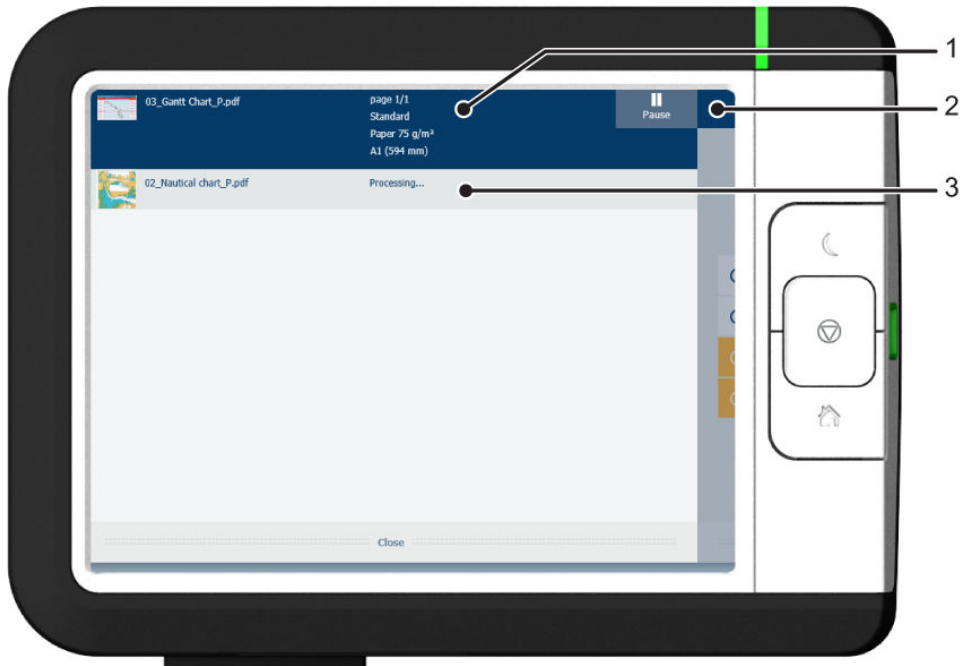

No.	Component	Function
1.	job and printer status	View information on the job and the printing system, such as: <ul style="list-style-type: none"> • Job information of the active job. • The printer status (e.g. printing, toner low, folder connected etc.).
2.	system menu	Tap the system menu thumbnail to access the system menu.
3.	job queue	Tap on the active job to open the job queue window. <ul style="list-style-type: none"> • See all the listed jobs and access them when you tap the job settings. • Move the listed jobs up or down the list.

System menu

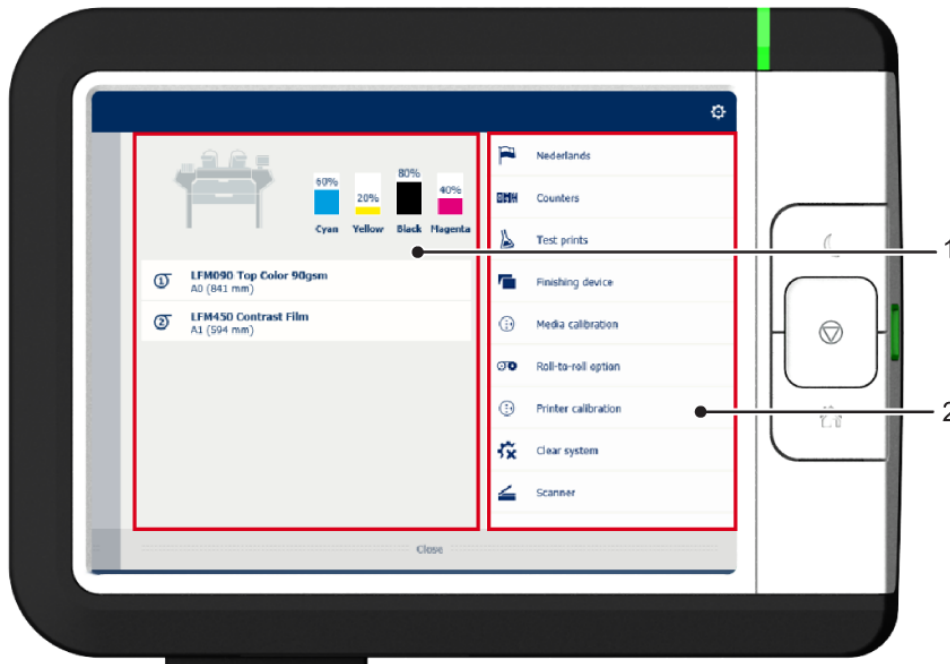

No.	Component	Function
1.	Printing system, media, and toner	<ul style="list-style-type: none"> The loaded media in the printer is displayed. The available toner per color is displayed. Wizards appear, to help you change media or refill toner.
2.	[setup menu]	<p>The [setup menu] gives general information on the printer. In the list you can get access to:</p> <ul style="list-style-type: none"> Switch between first and second language [Counters] [Test prints] [Finishing device] [Media calibration] [Roll-to-roll option] (with optional take-up module) [Printer calibration] [Clear system] [Scanner] (with optional scanner) [Network settings] [Security] [System update] [About]

Presets, templates and advanced settings

Introduction

Presets and templates help you to submit jobs quickly and easily. Advanced settings help you to fine-tune the settings of your job, and give access to all settings.

When you tap the copy tile in the home screen, a window with copy presets and advanced settings opens. When you tap the scan tile, the templates are visible in the Smart Access. When you tap the scan tile again, the window with the advanced settings opens. When you tap the print tile and tap the settings of a listed job, the window with print presets and advanced settings opens.

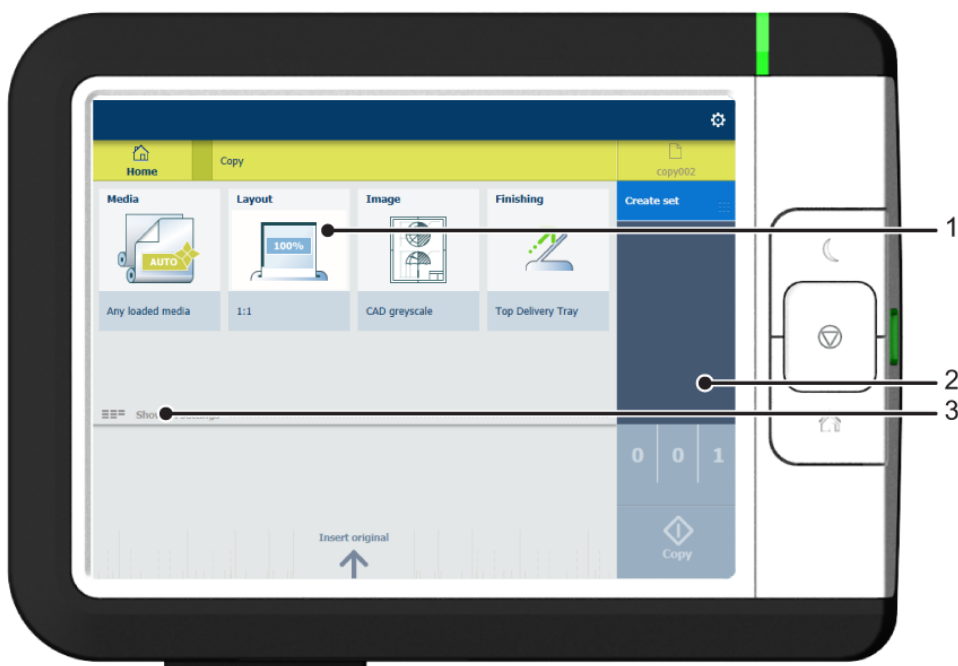

No	Component	Function
1.	[preset tiles]	The preset tiles show the default settings for your job. <ul style="list-style-type: none"> • The presets are divided into categories, such as [Media], [Layout] etc. • When you tap a preset tile, it gives quick access to a short list of other presets you can choose.
2.	[job pane]	The [job pane] helps to manage jobs. <ul style="list-style-type: none"> • Information is given on your job. • Make sets. • Delete a job. • Tap a tile to switch between the presets/settings window and a window with a preview of the document (only for Smart Inbox jobs). • Start a job with the green button.

No	Component	Function
3.	[Show all settings] (Advanced settings)	When you tap on [Show all settings], a list with all the advanced settings opens. For Scan, the advanced settings are already visible. <ul style="list-style-type: none">• The advanced settings are categorized and presented as tiles.• When you tap a tile you can fine-tune the settings.

Job preview

Introduction

The multi-touch user panel offers a detailed preview of your job. Touch the preview thumbnail to access the preview window.

Job preview

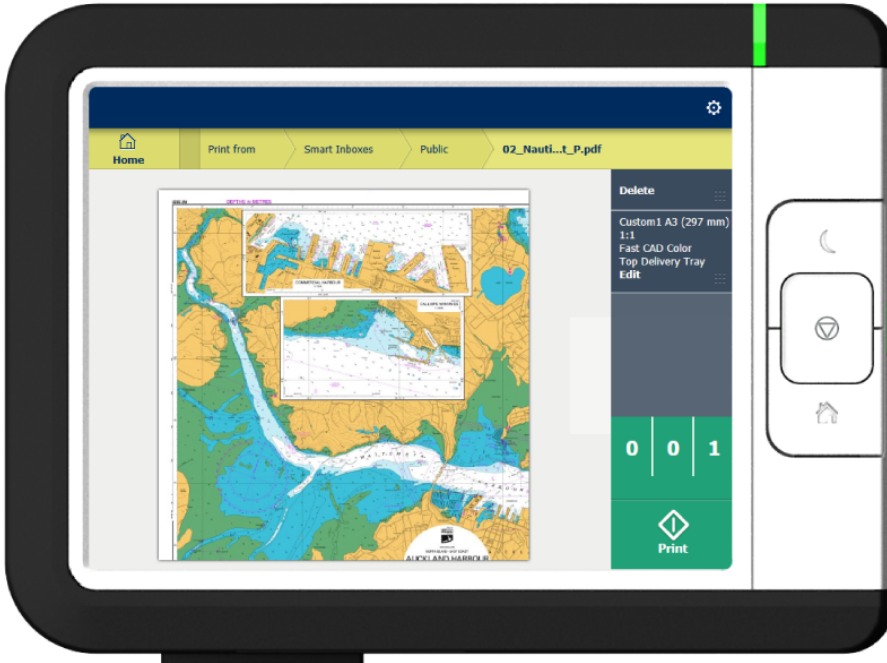

Component	Function
Job preview	<p>You can pan the image to see it in more detail.</p> <p>You can shift between the various job files that are part of one location. Swipe left or right to view the other job files.</p> <p>Tap the Edit tile in the job pane to open the preset window.</p> <p>In the preset window, tap the View tile to go back to the preview window.</p> <p> NOTE If you have a multi-page job, you can only view the first page.</p>

The cloud

Introduction

The multi-touch user panel gives the user the opportunity to print from and scan to various locations. One of these locations is the cloud.

You can enter the cloud via WebDAV and use it as a network drive. This way, the cloud application of your choice is accessible.



NOTE

- For more information on how to configure the cloud as an external location, see [Create an external location on page 121](#).
- Note that WebDAV is the type selected when creating a cloud location. For more information on how to use the cloud for print jobs, see [Use the cloud to send a print job on page 207](#).

Concept of the cloud

The cloud can be seen as a virtual network drive you use to send files to, but also to save and share files on.

There are general cloud applications, such as SharePoint or applications via a HTTP URL, but companies can also use their own private and internal clouds.

Working with the cloud on the ColorWave 3600 is very easy:

Procedure	Description	Via
Connection	Make a connection between your preferred cloud application and the printer. To do this, create an external location in WebTools Express via WebDAV .	WebTools Express
For print jobs:	Open the cloud application locally.	PC or mobile device
	Add and save the file you want to print, in the cloud. Or send your file to the printer in the cloud.	PC or mobile device
	Open your cloud application as location, in the Smart Access of the print tile.	user panel
	Select the file you want to print.	user panel
	Tap the green button.	user panel
For scan jobs:	Insert the original and select the scan tile.	user panel
	Select the template with the cloud set as destination in the Smart Access.	user panel
	Tap the green button.	user panel
	Open the cloud application on your PC or mobile device, and find the scanned file there.	PC or mobile device

Chapter 3

Define your workflow with WebTools Express

Getting started

WebTools Express

Introduction

WebTools Express is an application that runs embedded on your printer. Use an up-to-date Internet browser (Google Chrome, Microsoft Edge, Microsoft Internet Explorer or Mozilla Firefox) to open the homepage of WebTools Express on your computer or mobile device.

Definition

You can use WebTools Express to:

- Manage print, copy and scan jobs.
- Send print jobs to the printer with Publisher Express.
- Access the settings to manage the configuration and preferences of the printing system. When you want to change settings in WebTools Express, you must log in with one of three predefined user roles. For more information, see [About the users on page 11](#).
- Monitor the status of the printing system.

How to access WebTools Express

To access WebTools Express:

- Enter the product name of the printer as a Hostname, for example `http://ColorWaveXXXX`, in the workstation web browser.
or
- Enter the printer's IP address, for example `http://123.123.23.123`, in the workstation web browser.



NOTE

When WebTools Express does not appear, contact the network administrator to check the network parameters. Check whether the printer's network settings have been registered in the network infrastructure.

Set another language for WebTools Express

Introduction

The language setting of the Internet browser you use defines the language of WebTools Express.

Set another language

You can change the language of WebTools Express in your internet browser. Depending on the Internet browser you use you have to follow several steps to change the language. Use the specific help information in your browser to learn more. The Internet browsers that are supported are: Google Chrome, Microsoft Edge, Microsoft Internet Explorer and Mozilla Firefox.

The following languages are supported: Dutch, UK English, German, French, US English, Spanish, Danish, Italian, Swedish, Norwegian, Finnish, Portuguese, Polish, Hungarian, Czech, Japanese, Simplified Chinese, Traditional Chinese, Russian and Korean.



NOTE

- The language setting does not influence the language on the user panel. On the user panel, you can choose between the [First language] and the [Second language]. You can define the values for the [First language] and the [Second language] in the regional settings of WebTools Express.
- When the selected language cannot be supported, the default language for WebTools Express is US English.

Access management

Introduction

Access management is standard included with the printer and can be enabled or disabled via the user authentication option. Access Management is designed to help protect sensitive print jobs and information from unauthorized access. Only the owner of the job can access the job.

Secure printing and scanning

When user authentication is enabled:

- The sensitive print jobs sent by the job owner are not printed until the job owner authenticates on the system user panel and releases them for printing.
- The print jobs are stored in the printer and only the job owner can access them.
- Copying and scanning operations are accessible only after the user authenticates on the system user panel.

Three different methods can be used for user authentication:

- Username and password:
Username and password are required on the printer user panel.
- Smart card:
A valid smart card must be inserted into the smart card reader (plugged into the USB port on the printer).
- Contactless card:
A valid contactless card must be hold close to a contactless card reader (plugged into the USB outlet).

These authentication methods are intended for Windows-based environments with Microsoft Active Directory.

Scan-to and print-from the home folder

The options to scan-to and print-from the home folder are available with the username and password authentication method. After entering authentication on the printer user panel, you can scan a file to (or print a file from) your home directory on the network, as configured for your own account on Microsoft Active Directory. You can access the home directory through the LDAP protocol with an authentication. For the scan-to-home option, you can only retrieve your scans located on your home folder after you have authenticated on your own account on any workstation.



NOTE

The Home folder is a personal and secure external location, you can only use when it is configured by your IT department as part of your infrastructure.

Log in as an authorized user

To change certain settings, you must log in as an authorized user. There are three user roles: System Administrator, Key Operator and Power User. They have authorization to edit specific groups of settings. You do not need to log in before you start a session. The system will only display a login screen when you want to perform a special action.



IMPORTANT

It is possible to disable the local accounts in WebTools Express in the [Security] - [Configuration] - [User access configuration] section and enable network authentication instead. When network authentication is enabled, the AD user names are mapped on the user roles (System administrator, Key operator, or Power user). When logged in with the AD credentials the user is authorized to change all the settings in WebTools Express that correspond with his user role, without having to log in again.

For more information about network authentication refer to the PlotWave-ColorWave Systems Security - Administration guide on "<http://downloads.cpp.canon>".

Upon login



NOTE

- Once you have logged in, the log in lasts for the duration of the browser session. If you have not been active for more than 30 minutes, the session expires and you need to login again.
- For security reasons it is advised to periodically change the password of the three access modes (Key operator, System administrator, Power user).

For local accounts you can do this in WebTools Express.

When network authentication is enabled, this is handled by the IT password policy.

Procedure

1. Click on the value of the setting you want to edit. A login window opens.
2. Select a user role from the drop-down list.
3. Enter the password.
4. Click [Ok] to confirm your entry.

Log out after your session

Purpose

When you have finished the modification of a setting, it is advised to log out again.

Procedure

1. Click the log out hyperlink in the **top right-hand corner** of the screen.
or
2. Close the screen of your internet browser.

Change the password for authorized users or the password encryption key

When to do

For security reasons it is advised to periodically change the password of the three access modes (Key operator, System administrator, Power user).

For local accounts you can do this in WebTools Express.

When network authentication is enabled, this is handled by the IT password policy.

[Password encryption key]

This key is used to securely encrypt all stored password on the device. Not knowing this key, it is impossible for a third party to decrypt any stored password. It is advised to change the system default password encryption key after the system is installed, re-installed or upgraded.

You can find this setting in the same section as the passwords.



IMPORTANT

Handle and store all passwords securely and with care. In case of forgotten passwords, a service technician can reset the Key operator, System administrator, Power user passwords only when his rights have been enabled by the System Administrator. ([Security] - [Configuration] - [Permissions for Service] - [Allow Service technician to reset passwords] - [Yes]). Otherwise the machine has to be reinstalled.

Procedure

1. Open the [Configuration] - [Connectivity] tab.
2. Under the [Passwords] section, select [Local Key Operator password], [Local System Administrator password], [Local Power User password], or [Password encryption key] depending on the setting you want to change. A new window opens.
3. Log in as:
 - Key operator to change the key operator password. The default key operator password is KeyOp.
 - System administrator to change the system administrator password. The default system administrator password is SysAdm.
 - Power user to change all the passwords. The default power user password is PowUsr.
 - System administrator or Power user to change the password encryption key.



NOTE

The passwords and the password encryption key are case sensitive. You can only use characters from the following range:

A-Z	a-z
0-9	_ - ~ ! ? @ # \$ % ^ * + = , . : ; / [] () { }

You cannot use Chinese, Cyrillic or Japanese characters.







4. Enter the new setting twice to confirm your input. The input is hidden.
5. Click [Ok] to confirm, or [Cancel] to reject your entries.

The job states







Introduction

When a job is placed in a Smart Inbox or in the job queue, the icon in front of the job name gives information about the status of the job.

Overview of the job states in the Smart Inbox

State	Icon	Description
Receiving		Indicates that the Smart Inbox is receiving the job data.
New		Indicates that a new job is available in the Smart Inbox.
Queued		Indicates that the job is copied to the queue and waiting to be printed.
Printed		Indicates that the job has been printed.
Attention needed		General error message.
Account data missing		State when the account data for the job is missing.

Overview of the job states in the Job queue

State	Icon	Description
Receiving		Indicates that the Queue is receiving the job data.
Processing		Indicates that the Queue is processing the job data.
Ready to print		Indicates that the job is ready for printing.
Scheduled		Indicates that the job is waiting to be printed.
Printing		Indicates that the job is currently being printed.
Attention needed		General error message.















The system monitor

Introduction

You can open the system monitor to get an overview of the current status of the printing system. When you click on the system tab in the lower left corner of the screen, the system monitor opens.



The system state (for example: [Printing:]) is displayed in the upper right corner of the system monitor section of WebTools Express.

Overview of the system states

State	Icon	Description
[User intervention re-quired]		The user is requested to go to the printer and follow the instructions displayed on the user panel.
[System memory is full]		Status message when printer does not print because the system memory is full.
[Out of toner]		Status message when printer does not print because the printer is out of toner.
[Sleeping...]		Energy saving state: State when not all functionality is available due to printer sleeping.
[Warming up...]		State when not all functionality is available due to printer warming up.
[Initializing...]		State when the system software is initializing.
[Printer paused]		The system pauses the print queue but keeps access to all other functionality.
[Processing...]		The system is receiving or processing data.
[Ready to print]		State when there is no active job and no waiting job. When a job arrives, no user intervention is needed to start printing.
[Printing:] <job-name>		State when a print job is active.
[Processing:] <job-name>		The system is processing the job data.
[Receiving:] <job-name>		The system is receiving the job data.
[Optimizing print quality, please wait...]		The system is making settings to optimize the print quality.
'Media indication'		Roll media and roll width indication for each roll.

The scanner states



State	Icon	Description
[User intervention re-quired]		General error message.

State	Icon	Description
[Scanner is busy]		The scanner is active.
[Scanner is ready]		The scanner is ready to start a scan job.

The toner states

Icon	Description
	Toner OK
	Toner low, or empty.

The Remote Service States

Icon	Description
no icon	The printer is connected to [Remote Service]
	[Remote Service] is either: <ul style="list-style-type: none"> disabled, or enabled, but connection to [Remote Service] is not possible A tooltip is available with extra information.
	Remote assistance to the system is enabled and currently accepting a connection.

The E-shredding states

Icon	Description
no icon	E-shredding is disabled.
	E-shredding is enabled or busy. A tooltip is available with extra information.

The roll-to-roll states

Icon	Description
no icon	The system is in roll-to-sheet mode
	The system is in roll-to-roll mode. The printer will not cut between pages. The take-up unit can be used.

Shut down or restart the system



NOTE

For this procedure, you need to log in as a System Administrator.

To remotely shut down the printing system, you can click on [Shut down] in the Support tab of WebTools Express.

To restart the printing system, you can click on [Restart] in the Support tab of WebTools Express.

Define the defaults

About the default settings in WebTools Express

Definition

Before you send jobs to the printer, remember the following:

The values defined in WebTools Express are default values for the general system behavior. You can define a number of job settings in the printer drivers or the job submission tools. The settings defined in the printer drivers or the job submission tools always overrule the settings defined in WebTools Express.

How to edit a setting

Introduction

In WebTools Express, you can make settings to personalise your printing system.



NOTE

- Before you can edit a setting or a settings group, you must log in as an authorized user.
- You may have to reboot the system after you changed the settings.

Procedure

1. Browse to the settings group you want to edit, for example [Preferences] - [System defaults] - [Regional settings].
2. Click directly on the value of a setting, when you want to edit a single setting
or
click [Edit] in the settings group bar to access a window with all settings if you want to edit more settings in the group.
3. Modify the settings. A setting is enabled when you check the box.
4. Click [Ok] to confirm, or [Cancel] to reject your entries.

View and check the settings

Introduction

In WebTools Express you can view and check your settings. You can also check which settings are no longer set to the factory default value.

Procedure

1. Open the [Configuration] tab or the [Preferences] tab.
2. Click on [View configuration] in the upper right-hand corner of the screen. A window opens.
3. Scroll through the list of settings. The first column displays the setting and the second column displays the values. A "*" indicates that the value of the setting is different than the original factory default value.



NOTE

You can print the information with the standard print function of your browser.

Save the settings in a file

Introduction

Save the settings and the values that you configured in WebTools Express in a file.

Save the settings in a file to duplicate the settings very easily to another printer of the same type.



NOTE

Not all settings are stored in the settings file. The network settings are excluded from the file because the network settings cannot be transferred to another printer. The passwords for authorized users and the passwords for external locations are excluded from the file for security reasons. License information is not included in the file either.

Procedure

1. Open the [Configuration] tab or the [Preferences] tab.
2. Click on [Save configuration] in the upper right-hand corner of the tab. A window opens.
3. Navigate to a location on the network to store the file.
4. Save the settings<hostname of printer><date>.xml file. The file name is not fixed. You can change the name if required.
5. Click [Ok] to confirm, or [Cancel] to close the window without storing the file.

Load the settings from a file

Introduction

Load the settings and the values for WebTools Express from a file. Load the settings from a file to duplicate them to another printer of the same type.



NOTE

- Not all settings are stored in the settings file. The network settings are excluded from the file because the network settings cannot be transferred to another printer. The passwords for authorized users and the passwords for external locations are excluded from the file for security reasons. License information is not included in the file either.
- For this procedure, you need to log in as a Key operator, System administrator, or Power user. The loaded settings depend on the login profile. Only the settings corresponding to the user login are loaded.

Procedure

1. Open the [Configuration] tab or the [Preferences] tab.
2. Click on [Restore configuration] in the upper right-hand corner of the screen. A window opens.
3. Navigate to a location on the network and select the settings file.
4. Click [Ok] to load the settings file, or [Cancel] to close the window without loading the settings file.

In some cases a reboot dialog will appear.

Result

The values of the settings in the settings file overwrite the current values. The network configuration settings of the system and the passwords are not loaded to prevent connectivity problems and to guarantee the integrity of the passwords.

Restore the factory defaults

Introduction

Sometimes you want to go back to the initial settings. You can restore the factory default settings in WebTools Express.



NOTE

Log in as a Key Operator to only restore the Key Operator settings. Log in as a System Administrator to only restore the System Administrator settings. To restore all the factory default settings you must log in as a Power User.

Procedure

1. Open the [Configuration] tab, or the [Preferences] tab.
2. Click on [Restore defaults] in the upper right-hand corner of the screen. A window opens.
3. Click [Ok] to restore the factory default settings, or [Cancel] to close the window without restoring the factory defaults.

Set the print job default settings

Definition

In Webtools Express you can configure the default values for the print job settings.

The print job settings are grouped under the [Preferences] - [Print job defaults] tab. You can find a short explanation of the most important print job default settings below. Under the print job default settings you can also define the print presets that are visible on the user panel. For more information on the print presets, see [Set the default print preset on page 107](#).



NOTE

When you define print job settings in the printer drivers or the job submission tools, these values always overrule the default values defined in Webtools Express.

Overview of the [Print job defaults] - [Basic] settings

Open the [Preferences] - [Print job defaults] tab. Go to [Basic] and click edit in the upper right hand corner.

Setting	Description
[Number of sets]	Enter the default value for the number of times you want your jobs to be printed.
[Collate]	<ul style="list-style-type: none">• Select [On (sort by set)] to sort your output by set (123 - 123).• Select [Off (sort by page)] to sort your output by page (11 - 22 - 33).
[Print delivery]	<ul style="list-style-type: none">• Select [Top Delivery Tray (TDT)] to default deliver your output in the Top Delivery Tray.• Select [Back output] to default deliver your output at the back of the printer.
[Color mode]	<ul style="list-style-type: none">• Select [Color] to default print in color.• Select [Grayscale] to default print in greyscale.
[Fold]	Indicates if all the printed documents must be folded by default or not when a folding device is configured with the printing system. Select [Yes] to fold the printed documents by default, otherwise select [No].

Overview of the [Print job defaults] - [Sheet] settings

Open the [Preferences] - [Print job defaults] tab. Go to [Sheet] and click Edit in the upper right-hand corner.

Setting	Description
[Media source]	<p>Select the default output material and format for the media used on the printer.</p> <ul style="list-style-type: none"> • Select [Automatic] to automatically select the media. • Select the specific roll number of the media you want to use by default. <p>The system screen on the printer user panel displays the loaded rolls.</p> <p> NOTE You can only configure the Media selection policy setting, when Media source is set to [Automatic].</p>
[Media selection policy]	<ul style="list-style-type: none"> • Select [Automatic next larger] to allow the printer to use a media roll larger than the size of the print, when the exact size is not available. • Select [Automatic exact fit] to only allow the printer to use a media roll that has the exact media size of the print. When the media roll with the exact media size is not available a media request appears.
[Cut method]	<ul style="list-style-type: none"> • Select [Standard] to cut the print at a standard media size (DIN, ANSI etc.). • Select [Synchro] to cut the print at the end of the image. • Select [Custom] (numeric) to cut the print at a specific length.
[Custom print length]	Enter the cut length of your print job.
[Add leading strip]	When you enter a value, the printer adds a blank strip of the specified length at the top of the output.
[Add trailing strip]	When you enter a value, the printer adds a blank strip of the specified length at the bottom of the output.

Overview of the [Print job defaults] - [Layout] settings

Open the [Preferences] - [Print job defaults] tab. Go to [Layout] and click edit in the upper right hand corner.

Setting	Description
[Scale]	<ul style="list-style-type: none"> • Select [Automatic scale to the media size] to scale the image to the media. • Select [Automatic scale down when image is larger than media] to scale down the image one format smaller than the original. • Select [Custom scale factor] to enter your own scale percentage, with 100 percent as no scaling.
[Mirror]	Select [On] to mirror the image along the vertical axis - the media transport direction. ▶

Setting	Description
[Finishing Assistant]	When [Enabled]: For folded output the Finishing Assistant will automatically detect the legend (if present) in an image and rotate and align the image so the legend will be on the cover page of the folded package. If no legend can be detected the print will be delivered unfolded. For folded output enabling the Finishing Assistant overrules the rotation and alignment defaults.
[Rotation]	Select any option to rotate the image counterclockwise. When you want to print faster, select [Long edge first]. You can print faster due to less media transport. Select [Automatic media saving] to use the media in the most efficient way. For more information, see Set the rotation mode on page 149 .
[Alignment]	Select any of the options to define where to align the image on the media. For more information, see Set the alignment mode on page 150 .
[Horizontal shift]	Define how much you want the image to shift horizontally in the chosen alignment position.
[Vertical shift]	Define how much you want the image to shift vertically in the chosen alignment position.

Overview of the [Print job defaults] - [Image] settings

Open the [Preferences] - [Print job defaults] tab. Go to [Image] and click Edit in the upper right-hand corner.

Setting	Description
[Print quality]	Select [Print Assistant] (OPA) to automatically select the best print quality based upon the content of the file or manually choose a print quality yourself. The choice of the print quality affects the speed of the job and the toner coverage. For more information, see Set the print quality on page 145 .

Set the copy job default settings

In WebTools Express, you can configure the default values for the copy job settings.

The copy job settings are grouped under the [Preferences] - [Copy job defaults] tab. You can find a short explanation of the General copy job settings below. Under the copy job default settings, you can also make settings for the copy presets that are visible on the user panel. For more information on the copy presets, see [Set the default copy preset on page 105](#).

Overview of the [Copy job defaults] - [General copy job settings]

Open the [Preferences] - [Copy job defaults] settings tab. Click Edit in the upper right-hand corner of the [General copy job settings].

Setting	Description
[Media selection policy]	<ul style="list-style-type: none"> • Select [Next larger] to continue printing with a larger size media. • Select [Exact size], to only continue printing when the specified media size is available.
[Start value for ### in the copy job name]	Fill in the number that replaces the # hashes in the name of copy files. The number increases.
[File name for copy to Smart Inbox]	Fill in the copy filename used to save the copy in the Smart Inbox. When the copy file name contains one or more # hashes, the # hashes are replaced by ascending numbers.

Set the scan job default settings

In WebTools Express, you can configure the default values for the scan job settings.

The scan job settings are grouped under the [Preferences] - [Scan job defaults] tab. You can find a short explanation of the General scan job settings below.



NOTE

The file extensions that are defined in Scan job defaults, cannot be changed via the Smart Inbox.

Overview of the [Scan job defaults] - [General scan job settings]

Open the [Preferences] - [Scan job defaults] tab. Click edit in the upper right hand corner of the [General scan job settings] section.

Setting	Description
[File extension for scan-to-PDF]	Enter any text string. The string is the file extension for scan-to-PDF (default: PDF).
[File extension for scan-to-TIFF]	Enter any text string. The string is the file extension for scan-to-TIFF (default: TIF).
[File extension for scan-to-JPEG]	Enter any text string. The string is the file extension for scan-to-JPEG (default: JPG).
[File extension for scan-to-CALS]	Enter any text string. The string is the file extension for scan-to-CALS (default: CAL).
[Scan delivery retry interval]	When a scan is delivered to a remote location and scan delivery fails, the printer retries after the time you set here.

Configure the Smart Inbox settings

The Smart Inbox and the queue concept

Definition

You can use the Smart Inbox for customized job management. A Smart Inbox works as a personal mailbox from which you print jobs, in which you can store jobs, and where you can scan jobs to. Jobs that are waiting to be processed are visible in the queue.

The Smart Inbox and the queue concept

Concept	Used to
The queue	<ul style="list-style-type: none"> • Get a job printed as soon as possible. • Get feedback of the printer progress. • Cancel requests. • Change priority (local).
The Smart Inbox	<ul style="list-style-type: none"> • Send jobs to the system. • Keep together sets of documents from various origin. • Organize documents over various Smart Inboxes, to easily retrieve jobs. • Reprint jobs or change settings of jobs that are already sent to the printer.

Jobs in a Smart Inbox

You can use Smart Inboxes to manage your jobs. When you open the Jobs tab in WebTools Express the Smart Inbox section displays an overview of the Smart Inboxes. Define one or more Smart Inbox names that allow you to easily organize and access your jobs. For more information, see [The Smart Inbox in the Jobs tab on page 76](#) and [Create and open a Smart Inbox on page 78](#).

In the printer driver application or job submitter, you can select the specific Smart Inbox you want to print to. When a job is kept in the Smart Inbox, you can start the job manually on the user panel or in WebTools Express.

Under [Preferences] - [System defaults] - [Job management] you can determine rights, make settings for the Smart Inbox, and make more settings for general job management. For more information, see [Configure the job management settings on page 82](#)

The Smart Inbox in the Jobs tab

Introduction

In the Jobs tab you can create jobs or manage your jobs in the queue and the Smart Inbox.



NOTE

When the [User authentication] setting is enabled, your rights and view on the Jobs tab can differ.

the jobs tab

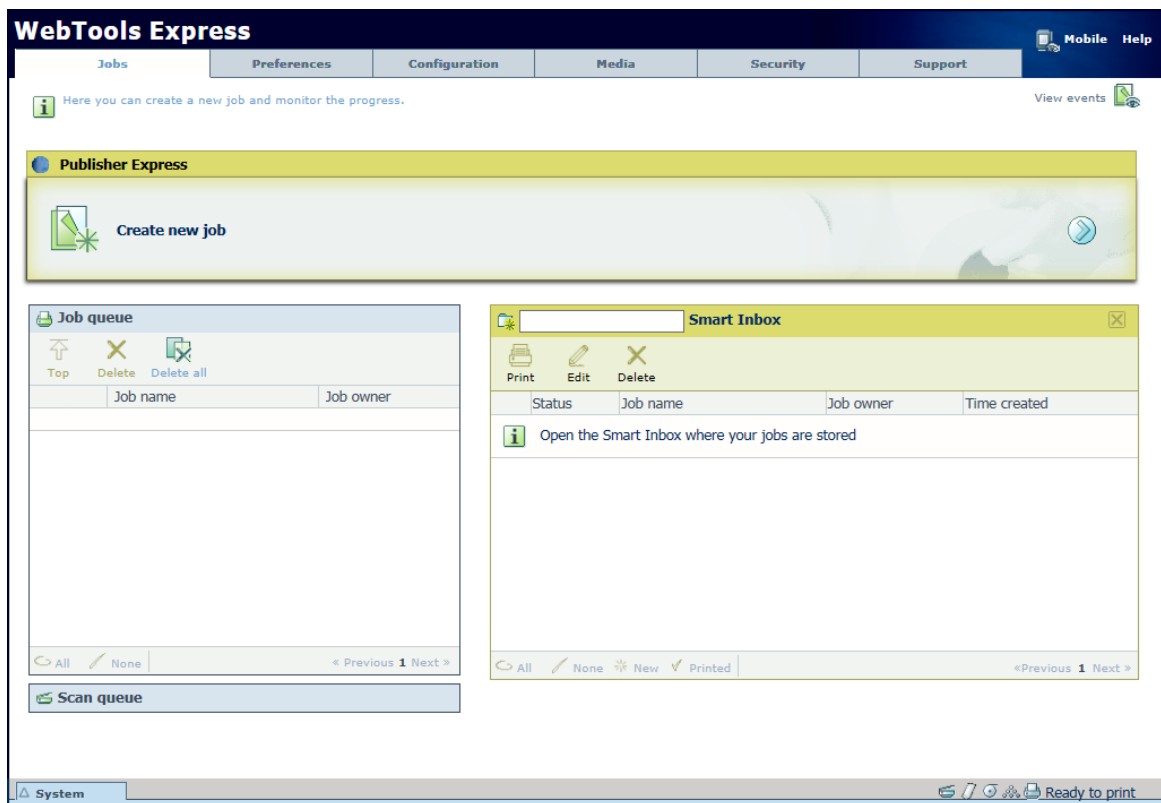

Create a new job in the Publisher Express section.

When you want to submit a new job, click [Create new job]. A new window opens, here you can define some basic job settings and browse to the file you want to print.

Monitor jobs in the Queue section.

In the Job queue and Scan queue you get an overview of the jobs waiting to be printed, or scans waiting to be sent. The options listed at the top of the queue section allow you to move a selected job to the top of the queue, to delete a job, to retry sending a job, or to send a scanned job to a specific location. When you click [Delete all] all jobs are deleted from the queue.

Control your jobs in the Smart Inbox section.

You can create and open a Smart Inbox in the Smart Inbox section. For more information, see [Create and open a Smart Inbox on page 78](#).

You can get an overview of all the Smart Inboxes on your system. Click on [Open Smart Inbox], click on the white space and select a Smart Inbox name from the list. The Smart Inbox appears below.

Perform actions on your jobs in the Smart Inbox. When you select a job in the Smart Inbox you can use the options listed at the top of the Smart Inbox section to print, edit, send to, save or delete the jobs.



NOTE

Depending on the selected job the available actions can differ.

Get an overview of all jobs on the system. When you enable the [Preferences] - [System defaults] - [Job management] - [Display a view on all Smart Inbox jobs] setting, all jobs can be displayed in one overview.

Create and open a Smart Inbox

Introduction

A Smart Inbox is used as a personal folder to print files from, scan files to, or store files in. In WebTools Express you can create a Smart Inbox in:

- The **[Jobs] tab - Smart Inbox** section.
- The **[Jobs] tab - Publisher Express** section.
- The **[Configuration] tab - [Smart Inbox]** section.



NOTE

- Note that the behavior of the Smart Inbox can differ, depending on which of the three ways is used for creation.
- When user authentication is enabled your Smart Inbox rights can differ.

Create a Smart Inbox in the [Jobs] tab - Smart Inbox section

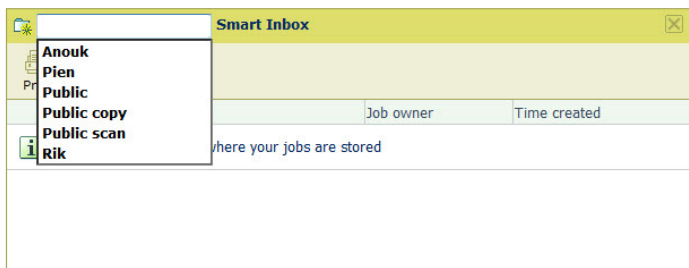

NOTE

- The Smart Inboxes created in the Smart Inbox section are, while empty, only visible on your personal browser. Once there is a job in the specific Smart Inbox, that Smart Inbox also becomes visible on the user panel and in other browser sessions.
- The Smart Inboxes created in the Smart Inbox section are not permanent. Once the Smart Inbox is empty, it will disappear from the user panel and from not-personal browser sessions.

Step	Action
1.	Select the [Jobs] tab.
2.	Click on [Open Smart Inbox].
3.	Click on the blank field to open a drop-down list with the Smart Inboxes available on your system.
4.	Enter the name of the new Smart Inbox and press Enter, or select the desired Smart Inbox from the list.
5.	The Smart Inbox is now displayed in the Smart Inbox section.

Create a Smart Inbox in the [Jobs] tab - Publisher Express section

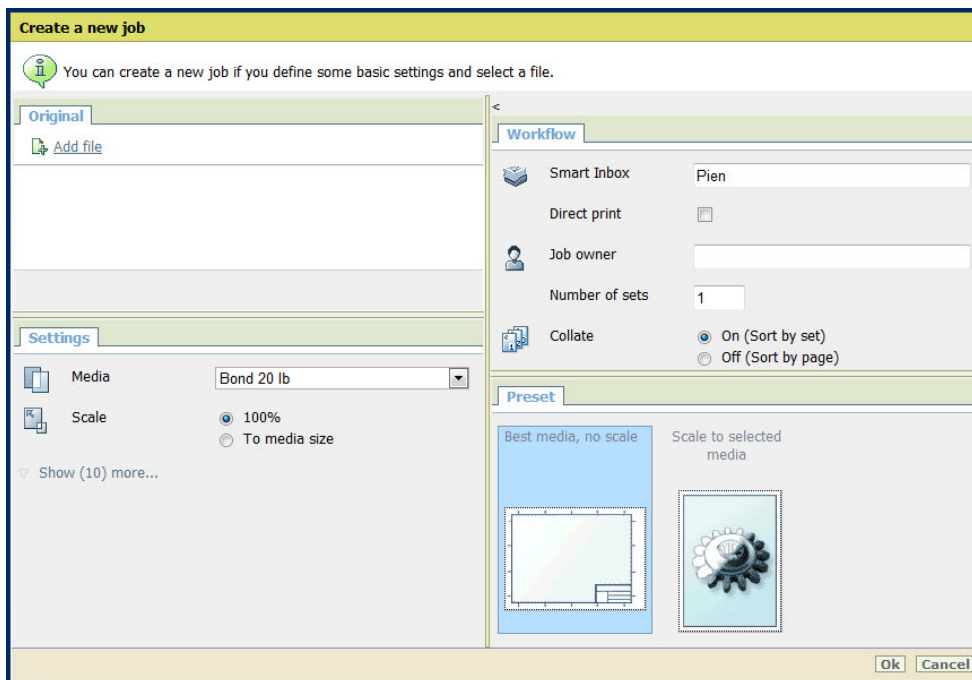

NOTE

- With this procedure you not only create a Smart Inbox, but you also send a job to the printer.
- The Smart Inboxes created in Publisher Express are, while empty, only visible on your personal browser. Once there is a job in the specific Smart Inbox, that Smart Inbox also becomes visible on the user panel and in other browser sessions.
- The Smart Inboxes created in Publisher Express are not permanent. Once the Smart Inbox is empty, it will disappear from the user panel and from not-personal browser sessions.

Step	Action
1.	Select the [Jobs] tab.
2.	Click on [Create new job] in the Publisher Express section.
3.	In the [Workflow] section, click on the Smart Inbox field. A drop-down list with Smart Inboxes that contain one or more jobs opens.
4.	Enter the name of the new Smart Inbox and press Enter.
5.	Click [Ok] to send the print job to the printer via the new Smart Inbox.
6.	The Smart Inbox is now displayed in the Smart Inbox section and on the user panel.

Create a Smart Inbox in the [Configuration] tab - [Smart Inbox] section

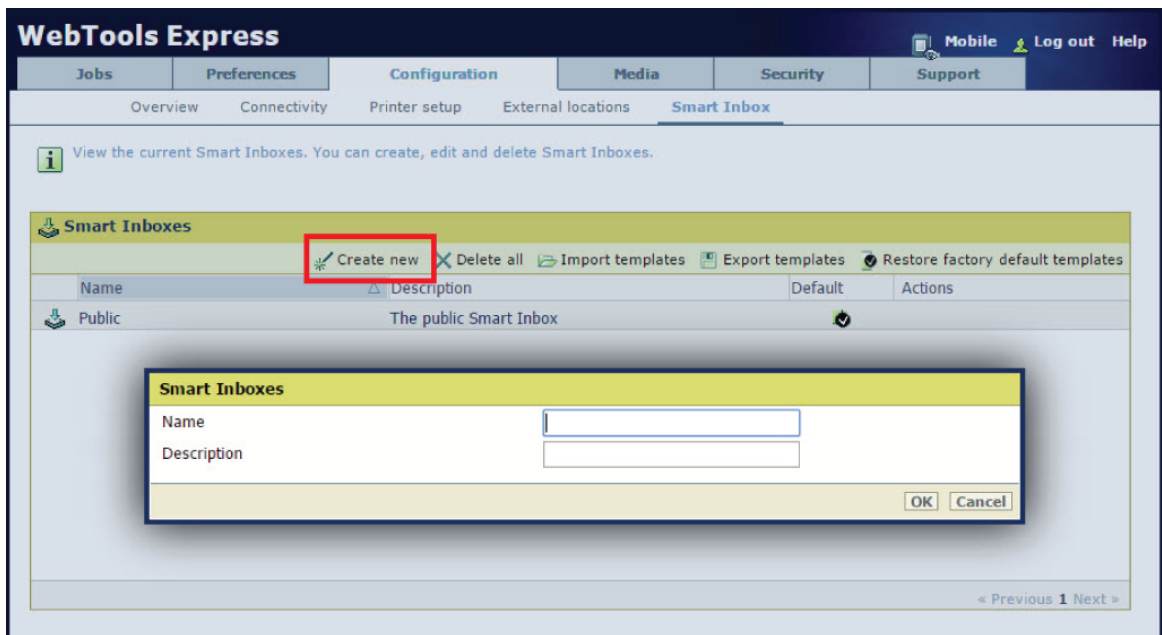

NOTE

The Smart Inboxes created in the [Configuration] tab - [Smart Inbox] section are permanent. Even when the Smart Inbox is empty, it will be available on the user panel and in the browser sessions.

Step	Action
1.	Open the [Configuration] - [Smart Inbox] tab.
2.	Click on [Create new]. A window opens.
3.	Enter a [Name] recognizable for the user. This name appears on the user panel.
4.	Enter a [Description].
5.	Click OK to confirm.

Close or delete a Smart Inbox

Introduction

In WebTools Express you can close or delete a Smart Inbox in:

- The **[Jobs] tab - Smart Inbox** section.
- The **[Configuration] tab - [Smart Inbox]** section.



NOTE

- When you delete a Smart Inbox, you only delete the view on the Smart Inbox, but not the content. To permanently delete the jobs from a Smart Inbox you must select the jobs in the Smart Inbox and click [Delete].
- The default 'Public' Smart Inbox cannot be deleted, and will always be present.

Close a Smart Inbox in the [Jobs] tab - Smart Inbox section

Step	Action
1.	Open the [Jobs] tab.
2.	Click on the X - button at the right hand side of the [Smart Inbox] bar.

Delete a Smart Inbox in the [Configuration] tab - [Smart Inbox] section

Step	Action
1.	Open the [Configuration] - [Smart Inbox] tab.
2.	Select the Smart Inbox you want to delete.
3.	On the right-hand side under [Actions], click on the X. If you want to delete all Smart Inboxes at once, click on [Delete all] in the upper right corner.

Configure the job management settings

Introduction

When you want to control the rights or actions that can be performed on jobs or Smart Inboxes, you can configure the [Job management] settings.

Attention:

- You can read a full explanation of each setting, when you click on the specific setting's name.
- When the [User authentication] setting is enabled, rights and the available settings can differ. For more information, see [Enable user authentication on page 89](#).

Procedure

1. Open the [Preferences] - [System defaults] tab.
2. Click [Edit] in the [Job management] section, or select a specific setting.
3. Change the values and make your preferred settings.
4. Click [Ok] to confirm, or [Cancel] to reject your entries.

Configure the network and security settings

Configure the network settings in WebTools Express

Introduction

Some of the network settings are configured during the installation of your system. When you want to define more network settings, you can do so under the [Configuration] tab.



NOTE

For more detailed information on network settings, refer to the ColorWave-Plotwave Connectivity Manual for Windows.

Procedure

1. Open the [Configuration] - [Connectivity] tab.
2. Click [Edit] in the upper right hand corner of the [Network adapter] section, the [Network adapter: IPv4] section or the [Network adapter: IPv6] section. Here you can edit all the settings of the group in one window.
or
3. Click on a single setting in the list to edit only one setting.



NOTE

You can always find a short explanation of the setting in the tooltip.

4. Click [Ok] to confirm, or [Cancel] to reject your entries.

Set the link speed and duplex mode

Introduction

Use WebTools Express to set the transmission speed and duplex mode for your network adapter.

Before you begin



NOTE

The list of values you can select depends on the network card type.

Procedure

1. Open the [Configuration] - [Connectivity] tab.
2. Click on [Edit] in the [Network adapter] section or click on the [Link speed and duplex mode] setting.
3. Select the value. [Automatic detection] is default.
4. Click on [Ok] to confirm or [Cancel] to reject your entries.

Set the security settings for Microsoft Internet Explorer

Introduction

You can use a web browser to open the home page of WebTools Express. Depending on the Internet browser you use, set the required minimum browser security settings as indicated below.



NOTE

You must enable cookies.

Procedure

Step	Action	Value
1	Select Tools / Internet Options / Security / Local intranet / Custom Level	
2	ActiveX controls and plug-ins	
	Binary and script behaviors	Enable
3	Downloads:	
	File download	Enable
4	Miscellaneous	
	Allow META REFRESH	Enable
	Launching applications and unsafe files	Enable
	Submit non-encrypted form data	Enable
	Use Pop-up blocker	Disable
5	Scripting	
	Active scripting	Enable

Set the security settings for Mozilla Firefox

Introduction

You can use an internet browser to open the homepage of WebTools Express. Depending on the Internet browser you use, set the required minimum browser security settings as indicated below.



NOTE

Don't block all cookies. Blocking is allowed for: Cross-site and social media trackers, cookies from unvisited websites and all third-party cookies.

Procedure

Step	Action	Value
1	Select Firefox / Options / Privacy & Security	
2	Enhanced Tracking Protection (Standard, Strict or Custom)	
	In case of 'Custom' , blocking of Cookies must not be set to 'All Cookies'.	

Set the security settings for Google Chrome

Introduction

You can use an internet browser to open the homepage of WebTools Express. Depending on the Internet browser you use, set the required minimum browser security settings as indicated below.



NOTE

You must enable cookies (blocking of third-party cookies is allowed).

Procedure

Step	Action	Value
1	Select Chrome / Settings / Privacy and security	
2	Site Settings	
	Cookies and site data	Allow sites to save and read cookie data (blocking of third-party cookies is allowed)
	JavaScript	Allowed
	Images	Show all

Set the security settings for Microsoft Edge

Introduction

You can use an internet browser to open the homepage of WebTools Express. Depending on the Internet browser you use, set the required minimum browser security settings as indicated below.



NOTE

Don't block all cookies. Blocking only third-party cookies is allowed.

Procedure

Step	Action	Value
1	Select Edge / Settings / Privacy & security	
2	Privacy & security/ Cookies	
	Don't block all cookies. Blocking only third-party cookies is allowed.	

Enable user authentication

Introduction

You can enable user authentication in WebTools Express.

When user authentication is enabled:

- Users have to authenticate to get access to the system.
- Users will only see their own jobs.
- Already scanned files that have been locally stored on the controller cannot be retrieved.
- [Direct print] is disabled.
- Various [Job management] settings are disabled.
- Various Smart Inbox rights are disabled.
- Various [Other network interfaces] settings are disabled.



NOTE

For more details on user authentication and a full list of disabled settings please refer to the PlotWave-ColorWave Systems Security manual.

Procedure

1. Open the [Security] - [Configuration] tab.
2. In the [User access mode] section, click on the [User authentication] setting.
3. Change the [User authentication] setting to the required authentication.
 - [User name and password]: the user has to select the domain and enter his credentials (user name and password) to get access to the system.



NOTE

- At least one domain has to be configured under the [Domains] tab, for more information refer to the security manual.
 - When you set user authentication to [User name and password] and you have configured the domain, the [Home folder] will also become available as an external location if enabled by your IT department.
- [Smart card]: the user has to use a smart card to get access to the system.



NOTE

At least a root certificate has to be uploaded under the [Trusted certificates] tab, for more information refer to the security manual.

- [Contactless card]: the user has to use a contactless card to get access to the system.



NOTE

At least one domain has to be configured under the [Domains] tab, for more information refer to the security manual.

- [User name and password or smart card]: the user has to enter a user name and password or use a smart card to get access to the system.
 - [User name and password or contactless card]: the user has to enter a user name and password or use a contactless card to get access to the system.
4. Click OK to confirm.

Enable Access control

Introduction

When you want to control access to your printer, you need to enable access control in WebTools Express. With access control enabled, you are able to choose up to five hosts who are allowed to communicate with the printer through your network. This amount of hosts allows for flexible configuration.

For each of the hosts you can decide whether the communication from this host to the system needs to be encrypted by IPsec.

Procedure

1. Open the [Security] - [Configuration] tab.
2. In the [Access control] section, click on the [Access control] setting.
3. Change the [Access control] setting from [Disabled] to [Enabled]. The setting is enabled when you check the box.
4. Click OK to confirm.

Enable IPsec

Introduction

Enable IPsec when you want your communication with the printer to be encrypted by IPsec.

Procedure

1. Open the [Security] - [Configuration] tab.
2. In the [Access control] section, click on the [IPsec] setting.
3. Change the [IPsec] setting from [Disabled] to [Enabled]. The setting is enabled when you check the box.
4. Click OK to confirm.

Access control and IPsec settings

Introduction

When access control is enabled, you can edit the access control settings.

[Access control] and IPsec settings

Under [Security] - [Configuration] - [Access control], you can set the following settings for each of the 5 stations:

Setting	Description
[Access control station 1]	Enable or disable communication of this host with the printer.
[Access control station 1: IPv4 address]	The IPv4 address of the host is allowed to connect to the printer.
[Access control station 1: IPv6 address]	The IPv6 address of the host is allowed to connect to the printer.
[IPsec station 1]	Enable or disable IPsec. IPsec is a security protocol that encrypts the communication between the host and the printer.
[IPsec station 1: Pre-shared key]	The key for encryption of this host connected via IPsec. If empty, the default preshared key is used.

For IPsec you can set the following settings:

Setting	Description
[IPsec default pre-shared key]	This is the default key for encryption of hosts connected via IPsec. This key holds for all stations whose preshared key is unspecified.
[IPsec authentication method]	Select IPsec Authentication type: Preshared key, Certificates or both.
[Signature algorithm of the IPsec certificate]	Select the IPsec Signing Algorithm: RSA, ECDSA P256 or ECDSA P384.
[IPsec certificate type]	Select Certificate Type: Root or Intermediate.
[IPsec certificate]	Not Editable, displays 'Certificate not present' as default or the Certificate common name when present.



NOTE

For more details on these settings please consult the manual PlotWave-ColorWave Systems Security .

Enable or disable the e-shredding function

Introduction

The e-shredding function allows you to securely erase jobs from the system. This prevents unauthorized people from recovering deleted jobs. When the e-shredding function is enabled, you can select an e-shredding algorithm. You can enable the e-shredding function in WebTools Express. By factory default, the e-shredding function is disabled.



NOTE

For more details on these settings please consult the PlotWave-ColorWave Systems Security manual.

Procedure

1. Open the [Security] - [Configuration] tab.
2. In the [E-shredding] section, click on the [E-shredding] field.
3. Select [Enabled] or [Disabled]. The setting is enabled when you check the box.



NOTE

When e-shredding is enabled, the system may require more time to process jobs.

4. Click OK to confirm.

Select the e-shredding algorithm

Introduction

The e-shredding function allows you to securely erase jobs from the system. This prevents unauthorized people from accessing deleted jobs.

You can select one of the following algorithms:

- [Gutmann].
All jobs on the system are erased in 35 overwrite passes.
- [DoD 5220.22-M].
All jobs on the system are erased in three overwrite passes.
- [Custom] allows you to define the number of passes manually.

The factory default is [DoD 5220.22-M].



NOTE

Only set the number of overwrite passes to a number higher than 1 if your security policy requires it. An increase of passes can affect the performance.

Procedure

1. Open the [Security] - [Configuration] tab.
2. Click on [Edit] in the upper right hand corner of the [E-shredding] section.
3. Select the preferred method for the [E-shredding algorithm].
4. Click OK to confirm.

Specify the number of overwrite passes

Introduction

The e-shredding function allows you to erase jobs from the system. This prevents unauthorized people from accessing deleted jobs. You can manually enter the required number of overwrite passes. You can enter any number from 1 to 35. The factory default is 3.



NOTE

- Only set the number of overwrite passes to a number higher than 1 if your security policy requires it. An increase of passes can affect the performance.
- Note that more passes take more time.

Before you begin

Make sure that [E-shredding] is enabled. For more information see, [Enable or disable the e-shredding function on page 93](#).

Procedure

1. Open the [Security] - [Configuration] tab.
2. Under [E-shredding] click on [E-shredding algorithm] and select [Custom].
3. Under [E-shredding] click on [E-shredding custom number of passes].
4. Enter the required number of overwrite passes.
5. Click OK to confirm.

Remote security

Introduction

By default the first certificate delivered for the use of HTTPS is a self-signed certificate.

To ensure a fully trusted authentication, you can request and import a certificate delivered by a Certification Authority (CA-signed certificate). In WebTools Express you can generate a certificate request and later import the CA-signed certificate that you have received from the Certification Authority.

When you use a certificate, the client station that submits the print can check the identity of the controller.

Remote security: certificates

- By default, Canon delivers a Canon self-signed certificate. This certificate provides encryption of the print data between the client and the controller. It can be easily used. This self-signed certificate has not been signed by a Certification Authority, consequently the web browser will display a 'Certificate Error' message the first time you use the HTTPS protocol.
- When your security policy recommends it, the administrator can request and import a certificate delivered by a Certification Authority (CA-signed certificate). For more information on how to do this, see [Generate a certificate request on page 97](#), and [Import a CA-signed certificate: Check and import the root certificate on page 102](#).

Generate a certificate request

Introduction

To ensure a fully trusted authentication via HTTPS, 802.1X or IPsec, you can request and import a certificate delivered by a Certification Authority (CA-signed certificate).

To generate a certificate request follow the procedure below.



NOTE

First check with your IT department which values are required for the certificate request. For more details on these settings please consult the PlotWave-ColorWave Systems Security manual.

Procedure

1. Open the [Security] - [Printer certificates] tab.
2. Click on [Generate a certificate request]. A window opens.

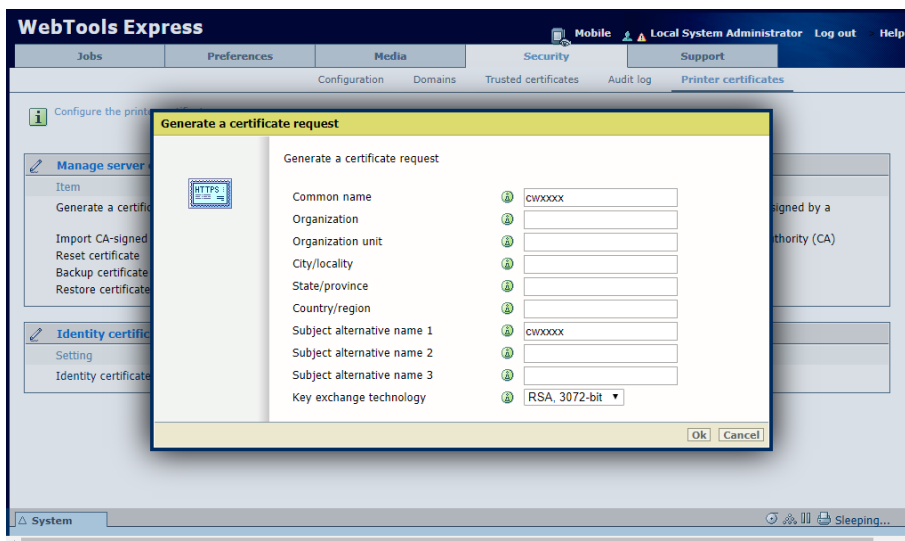

3. Make the required settings: fill in the fully qualified domain name or the IP address and the additional information.
4. Click [Ok] to save.
The web server generates a certificate request. The content of the request is displayed (plain text).

Example (fake request):

-----BEGIN NEW CERTIFICATE REQUEST-----

```
MIIBvDCCASQAwfDELMAkGA1UEBMCRIxDDAKBgNVBAgTA0IERjEQMA4GA1UEBxMHQ1JFVEV
J
TDEBEGA1UEChMKT2NIFBMVCBTQTEMMAoGA1UECxMDU05TMSowKAYDVQQDEyF0ZHM3M
DAAtNzQw
LnNucy5vY2VjcmV0WIsLm9jZS5uZwgZ8wDQYJKoZIhvcNAQEBBQADgY0AMIGJAoGBAJ2NKQM
d
HjiDZ1khzTJTORxHqjKl3AtE3PXqRsiHouTH5JTceYtaBjCnxCJ4pGKY5iKN8KJiJuZG8PHxY7o
W/+zpvxN2VtX7TcyTAvyCThUwL+cqo75tvODo5HMCUa2sLdl8GO9WMLpgZkxH5KzliO+Lcl4
yQbqhENynywS0C2ObXCq3yksF74+XIO0swhoA2yfDp4T+LuF3wxys8IUH3ZhhkOYg==
-----END NEW CERTIFICATE REQUEST-----
```

5. Click [Save to file] to save the content of the request in a .csr file (named 'req.csr' by default).

6. Send the content of this request to the Certification Authority.

Import a CA-signed certificate: Import the root certificate

Introduction

To ensure a fully trusted authentication via HTTPS, 802.1X or IPsec, you can request and import a certificate delivered by a Certification Authority (CA-signed certificate).

To import a CA-signed certificate you need to do the following.

- **Import the root certificate**
- Import the intermediate certificate
- Import a CA-signed certificate
- Check and import the root certificate

Complete all procedures to successfully import the certificate.



NOTE

For more details on these settings please consult the PlotWave-ColorWave Systems Security manual.

Procedure

1. Open WebTools Express
2. Open the [Security] - [Printer certificates] tab.
3. Click on [Import CA-signed certificate]. A window opens.
4. Select [Root certificate] in Certificate type.
5. Browse to the Root certificate file and click on Open.



NOTE

The Root certificate may already exist in the web server certificates list.

6. Validate to confirm the import.
7. When the message [Certificate successfully imported.] pops up, go on to import the [Intermediate certificate].
8. Click [Ok] to save.

Import a CA-signed certificate: Import the intermediate certificate

To ensure a fully trusted authentication via HTTPS, 802.1X or IPsec, you can request and import a certificate delivered by a Certification Authority (CA-signed certificate).

When you import the certificate you need to:

- Import the root certificate
- **Import the intermediate certificate**
- Import a CA-signed certificate
- Check and import the root certificate

Complete all procedures to successfully import the certificate.

Procedure

1. Open WebTools Express
2. Open the [Security] - [Printer certificates] tab.
3. Click on [Import CA-signed certificate]. A window opens.
4. Select [Intermediate certificate] in Certificate type.
5. Browse to the Intermediate certificate file and click on Open.
6. When the message [Certificate successfully imported.] opens, go back to the main page to import the [CA-signed certificate]

Import a CA-signed certificate

To ensure a fully trusted authentication via HTTPS, 802.1X or IPsec, you can request and import a certificate delivered by a Certification Authority (CA-signed certificate).

When you import the certificate you need to:

- Import the root certificate
- Import the intermediate certificate
- **Import a CA-signed certificate**
- Check and import the root certificate

Complete all procedures to successfully import the certificate.

Procedure

1. Open WebTools Express
2. Open the [Security] - [Printer certificates] tab.
3. Click on [Import CA-signed certificate]. A window opens.
4. Select [CA-signed certificate] in Certificate type.
5. Select 'Yes' to validate the certificate against Java root certificates and click 'Open'.
6. When the message [Certificate successfully imported.] pops up, restart the controller.
The certificate is now installed on the server.
Check and import (if needed) the CA Root certificate also into the workstations web browser. That will secure the complete data workflow between the workstations and the server.

Import a CA-signed certificate: Check and import the root certificate

To ensure a fully trusted authentication via HTTPS, you can request and import a certificate delivered by a Certification Authority (CA-signed certificate).

When you import the certificate you need to:

- import the root certificate
- Import the intermediate certificate
- Import the CA-signed certificate
- **Check and import the root certificate**

Complete all procedures to successfully import the certificate.

Procedure

1. On each workstation, open the web browser.
2. Open the 'Certificates' option of the browser.
For Internet Explorer: In the Tools - Internet Options - Content window, open "Certificates".
3. Check whether the CA Root certificate is already displayed in the "Trusted Root Certification Authorities" list.
4. If it is not on the list, import the CA Root certificate.

Find information about the Identity Certificate

Introduction

When a certificate is uploaded you can view the details of the certificate.

Procedure

1. Open the [Security] - [Printer certificates] tab.

When a certificate is uploaded you can see the following details in the [Identity certificate] section.

Setting	Description
[Identity certificate present]	Displays whether an identity certificate file is present on the controller.
[Valid from]	Displays the start date of the validity period
[Valid until]	Displays the end date of the validity period
[Valid for HTTPS]	Signed for HTTPS by certificate authority
[Valid for IPsec]	Signed for IPsec by certificate authority
[Common name]	Certificate's common name
[Key exchange technology]	Signing algorithm that is used

Configure the presets

What you need to know about presets

Introduction

A preset is a predefined setting that is available on the user panel to easily perform print or copy jobs. The preset concept supports the green button approach. The default presets are automatically selected on the user panel, so you only have to press the green button to start a job with your predefined settings.

Presets on the user panel

When you tap the copy tile on the user panel, a window opens with a list of presets. When you tap the print tile and tap the settings of a listed job, the print presets are shown.

Per preset category, the default preset is visible as a preset tile. When you tap the default tile, the other available presets are shown.

Set the presets in WebTools Express

In WebTools Express you can make the settings for the print or copy presets . You only have to make the settings once, and they will be visible on the user panel as presets.

Presets	Description
Default presets	The default presets support the green button approach. When you do not make settings, the printer uses the default presets for print or copy jobs. You can set the default presets in WebTools Express.
Custom presets	When you want to use your own preferred settings, you can configure custom presets in WebTools Express. Make the custom preset available on the user panel or set it as the default preset.

Set the default copy preset

Introduction

With a preset you can predefine the settings you need for a copy job.

Copy has four preset categories: [Media], [Layout], [Image], and [Finishing] For each category you can set one default preset in WebTools Express. The default preset is automatically used when you press the green button on the user panel.



NOTE

You can always find a short explanation of the setting in the tooltip.

Procedure

1. Open the [Preferences] - [Copy job defaults] tab.
2. Under [User panel configuration: Default presets for copy] select the preset category you want to change, for example [Default layout preset].
3. Select the setting you want to use as the default preset, for example [Standard half size].
When you want to make your custom preset default, select [Custom].
4. Click [Ok] to confirm, or [Cancel] to reject your entries.

After you finish

To make sure your preset is active on the user panel, press the home button on the home screen of the user panel.

Configure the custom copy preset

Introduction

With a preset you can predefine the settings you need for a copy job.

When you want to use other predefined settings than the default presets, you can configure custom presets in WebTools Express . You can configure one custom preset per preset category: [Media], [Layout], or [Image]. The custom preset becomes available on the user panel, and you are able to set it as the default preset.

Procedure

1. Open the [Preferences] - [Copy job defaults] tab.
2. Select the preset category you want to make a custom preset in and click on [Edit], for example [Custom image preset for copy].
3. Check the box next to the [Custom image preset for copy] setting to enable the preset, and make it available on the user panel.
4. Fill in a name and description that will be used for the preset on the user panel.
5. Select the settings you want to use for the custom preset, for example choose to set [Original type] to [Blueprint] , and [Background compensation] to [On].
6. Click [Ok] to confirm, or [Cancel] to reject your entries.

After you finish

To make sure your preset is active on the user panel, press the home button on the home screen of the user panel. When you want to make the custom preset the default preset, follow the procedure [Set the default copy preset on page 105](#).

Set the default print preset

Introduction

With a preset you can predefine the settings you need for a print job from USB or an external location.

Print has four preset categories: [Media], [Layout], [Image], and [Finishing]. For each category you can set one default preset in WebTools Express. The default preset is automatically used when you press the green button on the user panel.



NOTE

You can always find a short explanation of the setting in the tooltip.

Procedure

1. Open the [Preferences] - [Print job defaults] tab.
2. Under [User panel configuration: Default presets for print] select the preset category you want to change, for example [Default layout preset].
3. Select the setting you want to use as the default preset, for example [Standard half size]. Select [Custom] to make your custom preset default.
4. Click [Ok] to confirm, or [Cancel] to reject your entries.

After you finish

To make sure your preset is active on the user panel, press the home button on the home screen of the user panel.

Configure the custom print preset

Introduction

With a preset you can predefine the settings you need for a print job.

When you want to use other predefined settings than the default presets, you can configure custom presets in WebTools Express . You can configure one custom preset per preset category: [Media], [Layout], or [Image]. The custom preset becomes available on the user panel, and you are able to set it as the default preset.

Procedure

1. Open the [Preferences] - [Print job defaults] tab.
2. Select the preset category you want to make a custom preset in and click on [Edit], for example [Custom image preset for print].
3. Check the box next to the [Custom image preset for print] setting to enable the preset, and make it available on the user panel.
4. Fill in a name and description that will be used for the preset on the user panel.
5. Select the settings you want to use for the custom preset, for example choose to set [Mirror] to [On].
6. Click [Ok] to confirm, or [Cancel] to reject your entries.

After you finish

To make sure your preset is active on the user panel, press the home button on the home screen of the user panel. When you want to make the custom preset the default preset, follow the procedure [Set the default print preset on page 107](#).

Make a custom preset available on the user panel

Introduction

When you create a custom preset, you can enable the preset to make it available on the user panel.

Before you begin

Create the custom preset first. For more information, see [Create the custom copy preset on page 106](#) or [Create the custom print preset on page 108](#).

Procedure

1. Open the [Preferences] tab.
2. Select the [Copy job defaults] or the [Print job defaults] tab, dependent of your custom preset.
3. Under the preferred custom preset category, select the custom preset setting.
For example under [Custom image preset for copy], select the [Custom image preset for copy] setting.
4. Check the box to enable the setting and click [Ok].
The custom preset is now visible on the user panel, and can be selected locally.

Configure the templates

Fold and Scan templates

Introduction

A template is a group of predefined settings you can configure yourself. Select the template on the user panel to easily submit a job with optimized settings.

You can create templates for folding and scanning in WebTools Express under the [Preferences] tab. You can create various templates and select one of the templates as default. For scan templates you can also enable one of the factory installed templates.





General template actions

There are several general actions you can perform for templates. You can:

- [Create a new template on page 111](#)
- [Delete all templates on page 112](#)
- [Export templates on page 113](#)
- [Import templates on page 114](#)
- [Restore the factory defaults of the templates on page 115](#)
- [Enable or disable scan templates on page 116](#)

Actions per template

Next to this, you can perform actions per template. When you move the mouse pointer over the template in the list you can see the available actions:

Icon	Description
	[Edit a template], to change the settings or the destination. You can also modify factory installed scan templates.
	[Copy a template], to create a new template.
	[Delete a template], to remove one specific template.  NOTE <ul style="list-style-type: none"> • When you have deleted a factory installed scan template, you can retrieve it by restoring the factory defaults. For more information, see Restore the factory defaults on page 69. • Some destinations (external locations and Smart Inboxes) cannot be deleted when they are set as a scan destination in the scan template.
	[Set this template as the default template], to set one default selected template.

Create a new template

Introduction

Create a new template in WebTools Express.



NOTE

- Depending on the configuration, less or more settings are available.
- More or fewer settings will be shown depending on the selections made.
- Note that the templates on the user panel are ordered alphabetically. When you want to order the templates to your preference, it is advised to use ascending numbers in front of the name (01-02-03 etc.).
- Click on the home button on the user panel to update the templates.

Procedure

1. Select the [Preferences] - [Fold] tab in WebTools Express for the fold template.
Select the [Preferences] - [Scan] tab in WebTools Express for the scan template.
2. Click on [Create new] at the right hand side.
3. Enter a [Name], recognizable for the user.
4. Enter a [Description], a description of the settings used.
5. For the fold template: Select a [Template source].



IMPORTANT

If available, it is advised to use the templates embedded in the folding device to get the best results.

- Select [Custom template] when you want to define the fold settings yourself.
 - Select [Template embedded in folding device] when you want to use a template that is predefined in the folding device.
6. Select the desired settings. For every individual setting, there is a tooltip available in the template editor to give a short explanation.
For more information on the fold settings, see [Fold settings for custom fold templates on page 140](#) and [Fold settings for embedded fold templates on page 143](#).
 7. Click [Ok] to save the template or [Cancel] to reject your entries.

Delete all templates

Introduction

You can delete all templates at once with WebTools Express.

Procedure

1. Select the [Preferences] - [Fold] tab in WebTools Express for the fold templates.
Select the [Preferences] - [Scan] tab in WebTools Express for the scan templates.
2. Click on [Delete all] at the right hand side.
3. The system displays the message [Do you want to delete all the templates?]
4. Click [Ok] to delete all templates or [Cancel] to cancel the deletion.

Export templates

Introduction

You can export templates with WebTools Express.

The export will be saved as a zip file. The zip file contains all available templates.

Procedure

1. Select the [Preferences] - [Fold] tab in WebTools Express for the fold templates.
Select the [Preferences] - [Scan] tab in WebTools Express for the scan templates.
2. Click on [Export all] at the right hand side.
3. Click [Save] to save the export in a zip file or [Cancel] to stop the export.

Import templates

Introduction

You can import templates with WebTools Express.

Use a zip file with templates that was previously created by the [Export templates] procedure.

Procedure

1. Select the [Preferences] - [Fold] tab in WebTools Express for the fold templates.
Select the [Preferences] - [Scan] tab in WebTools Express for the scan templates.
2. Click on [Import] at the right hand side.
3. Mark the [Overwrite existing templates] checkbox to overwrite existing templates. When you do not tick the checkbox, duplicate imported templates will be given a serial number.
4. Click Browse to [Select the location of the zip file].
5. Click [Ok] to import all templates or [Cancel] to cancel the import.

Restore the factory defaults of the templates

Introduction

You can restore the factory defaults of all templates with WebTools Express.

The custom templates are not changed.

Procedure

1. Select the [Preferences] - [Fold] tab in WebTools Express for the fold templates.
Select the [Preferences] - [Scan] tab in WebTools Express for the scan templates.
2. Click on [Restore factory defaults] at the right hand side.
3. The system displays the message [Restore all factory default templates?]
4. Click [Ok] to restore the templates or [Cancel] to stop the restore.

Enable or disable scan templates

Introduction

You can enable or disable scan templates. When you enable the templates they become available on the user panel.

Procedure

1. Open the [Preferences] - [Scan] tab.
2. Under Actions, click on the [Edit a template] icon next to the preferred template. The template window opens.
3. Under [File], set the [Display on the user panel] setting to [Yes] or [No].
4. Click on OK to confirm your entry.

Result

When you have selected [Yes] the templates are available on the user panel in the Smart Access.



NOTE

The default scan template is always available in the Smart Access of the user panel, even when it is disabled.

Configure the locations

Configure your locations

Introduction

On the user panel you can find a list of locations you can scan to and print from.

To this location you send your scanned files for storage, or you save files on this location and you send them to the printer.

You can define the external locations under the [Configuration] - [External locations] tab in WebTools Express.

Type of locations

You can scan to and print from various location types.

Location type	Location type description
Smart Inbox	When you select this location, you can print from your personal Smart Inbox, or your scanned file is sent to the Smart Inbox of your choice.
[USB]	If you select this location you can print from or scan to the USB Mass storage device you inserted in the user panel.
[FTP]	If you select this location you can print from or scan to a shared folder on a remote workstation via FTP.
[SMB]	If you select this location you can print from or scan to a shared folder on a remote workstation via SMB.
[WebDAV]	If you select this location type, you can enter the cloud via WebDAV and use it as a network drive.
[Home folder]	<p>When you select this location type, you can print from or scan to your personal home folder on your own workstation.</p> <p> NOTE The home folder is only available when [User authentication] is enabled with [User name and password]. The home folder has to be configured by your IT department as part of your infrastructure.</p>
[PlanWell® Collaborate] (Optional)	When you select this location you can print from or scan to the PlanWell Collaborate cloud services.

Enable or disable USB

Introduction

If you want to use USB as a location, you have to make settings for USB first. You can make the settings in WebTools Express.

Illustration

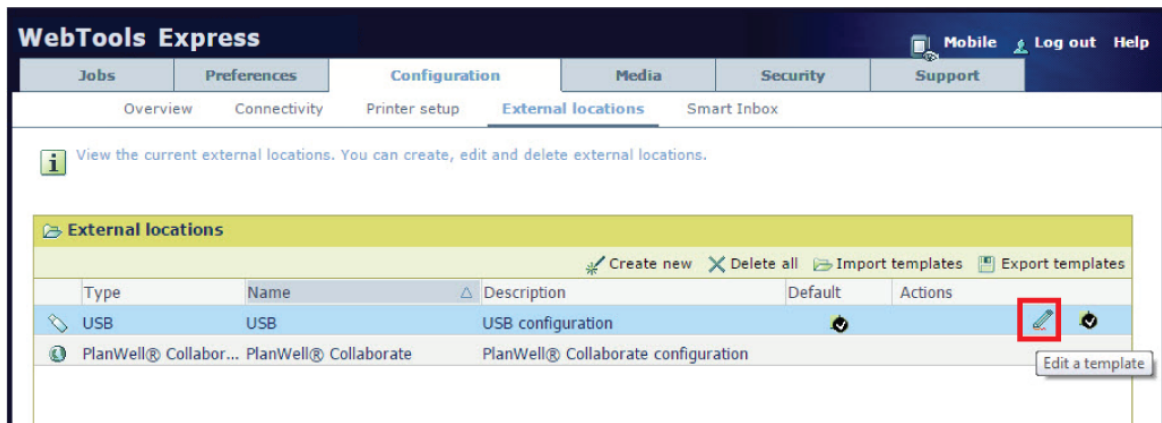

Procedure

1. Open the [Configuration] - [External locations] tab.
2. Select [USB], and click on the [Edit] icon under [Actions]. A window opens.
3. Enter the [Name] recognizable for the user. This name appears on the user panel.
4. Enter the [Description] of USB as location.
5. Under [Enabled functionalities] you can choose the functionalities you want to use for USB.
 - Choose [Print from and scan to], when you want to enable print from and scan to USB.
 - Choose [Print from only] if you want to enable print from USB only.
 - Choose [Scan to only] if you want to enable scan to USB only.
 - Choose [None] if you want to disable the USB functionality.
6. Click [Ok] to save the settings for USB as an external location.

Result

When you enable USB and insert a USB key on the user panel, the external USB location can be used via the user panel and in WebTools Express.

If you disable USB, USB cannot be used as an external location.

Enable and edit the Home folder

Introduction

When you want to use the Home folder as a location you have to enable user authentication first. Only then the Home folder becomes visible in the external location list. When it is present you can edit the functionalities.



NOTE

The Home folder is a personal and secure external location, you can only use when it is configured by your IT department as part of your infrastructure. You log in on the user panel using your credentials ([User name and password]) and only see your own home folder. When you scan to the home folder, the file is delivered on your own personal location on the network. In a typical configuration you can find the file on your workstation under the home drive.

Before you begin

Make sure you enable the [User authentication] setting by selecting the value [User name and password] first. For more information, see [Enable user authentication on page 89](#)

Procedure

1. Open the [Configuration] - [External locations] tab.
2. Select [Home folder], and click on the [Edit] icon under [Actions]. A window opens.
3. Under [Enabled functionalities] you can choose the functionalities you want to use for the home folder.
 - Choose [Print from and scan to], when you want to enable print from and scan to the home folder.
 - Choose [Print from only], when you want to enable print from the home folder only.
 - Choose [Scan to only], when you want to enable scan to the home folder only.
 - Choose [None], when you want to disable the home folder as an external location.
4. Click [Ok] to save the settings for the home folder as an external location.

Enable PlanWell Collaborate (optional)

Introduction

When you have a license installed for PlanWell Collaborate (ARC cloud support), you can enable this external location under the [Configuration] tab.

Procedure

1. Open the [Configuration] - [External locations] tab.
2. Select [PlanWell® Collaborate], and click on the [Edit] icon under [Actions]. A window opens.
3. Check the box to [Use proxy settings]. When you configure the location on a local network it can be necessary to uncheck the box and not use the proxy settings.
4. Under [Enabled functionalities] you can choose the functionalities you want to use for PlanWell Collaborate.
 - Choose [Print from and scan to], when you want to enable print from and scan to PlanWell Collaborate.
 - Choose [Print from only], when you want to enable print from PlanWell Collaborate only.
 - Choose [Scan to only], when you want to enable scan to PlanWell Collaborate only.
 - Choose [None], when you want to disable PlanWell Collaborate as an external location.
5. Click [OK] to save the settings for PlanWell Collaborate as an external location.

Create an external location

Introduction

You can create your own FTP, SMB, WebDAV, external locations with WebTools Express.



NOTE

For more detailed information on network settings, refer to the ColorWave-Plotwave Connectivity Manual for Windows.

Before you begin



NOTE

- Make sure you enable [SMB] protocol.
- Make sure you enable [FTP] under the [Configuration] - [Connectivity] tab.
- Make sure the URL for [WebDAV] is not blocked.
- For this procedure, you need to log in as a System Administrator.

Procedure

1. Select the [Configuration] - [External locations] tab.
2. Click on [Create new] in the upper right-hand corner.

3. Enter a [Name] recognizable for the user. This name appears on the user panel.
4. Enter a [Description] of the settings used.
5. Select the [Type] of the external location: [FTP], [SMB], or [WebDAV].
6. Enter the [Path]. The folder path or URL to the external location.
 - For [FTP], use the syntax: hostname[/path] (example: myhost/mydirectory/scantofile).
 - For [SMB], use the syntax: \\hostname\sharename[/path] (example: \\myhost\myshareddirectory\scantofile).
 - For [WebDAV] locations, use the full HTTP URL (for example: http://example.webdav.org:8080/repository/).
7. Select under [Credentials] whether or not the user has to log in to access the external location.
 - Select [Prompt the user to log in on the user panel] when you want the user to log in on the user panel.
Login will appear when the user tries to access the external location on the user panel.
 - Select [Use the following credentials for automatic login:] when you want to configure the credentials here.
The user is not requested to log in on the user panel when he tries to access the external location.

8. If you have selected [Use the following credentials for automatic login:] fill in the username and password.
 - The [Username] gives access to the external location. The user must at least have read and write permissions for the external location. For SMB destinations the format must be as follows: Local user name: "IPaddress\username" or "hostname\username". Domain user name: "domain\username".
 - Enter the [Password] that belongs to the username.
9. Select the [Enabled functionalities]. Enable or disable access to the selected location for print or scan jobs.
10. Click [Ok] to save the external location.



NOTE

The system will validate the external location and give an error message if the validation fails.

In case of an error, you can click "Save" to save the external location with the error or click "Change" to change the entries.

Result

The external location can be used via the user panel and in WebTools Express.

Set a default external location

Introduction

You can set an external location as the default location. The default location is used when you do not select a specific external location for a job.

Procedure

1. Select the [Configuration] - [External locations] tab.
2. Under [External locations] select the external location you want to set as default.
3. Click on the checkbox icon under [Actions].

Set a default print destination

Introduction

You can configure the default print destination in WebTools Express. When the destination of a print job is not specified in the job ticket or when there is no job ticket, the job is sent to a default destination. You can choose between two default print destinations:

- [Both queue and Smart Inbox]: the job is printed automatically and stored in the Smart Inbox.
- [Only Smart Inbox]: the job is sent to the Smart Inbox and you have to start it locally.



NOTE

You can only set the default print destination, when the [Override destination of print jobs] setting is set to [No, as specified in the job ticket]. You can find this setting under [Preferences] - [System defaults] - [Job management].

Procedure

1. Select the [Preferences] - [System defaults] tab.
2. Click on [Edit] in the [Job management] section, or click on the setting [Default destination of print jobs].
3. Select [Both queue and Smart Inbox] or [Only Smart Inbox].
4. Click [Ok] to confirm, or [Cancel] to reject your entries.

After you finish



Your preferred print destination is now default. All print jobs are sent to this destination when you do not make other settings.

Troubleshoot the creation of an FTP external location (after an error message)

An error message displays to indicate that the creation of the FTP external location failed.

According to the error message, perform the verifications proposed in the next table in order to fix the issue.

Error message	Action to perform
The user name or password is incorrect.	<p>Check the remote user name and the password. If the user name and password are correct, check the syntax of the external location name:</p> <ul style="list-style-type: none"> - For a remote host user: <hostname>\<username> or <IP_address>\<username> • For a domain user: <domainname>\<username>
The remote hostname cannot be resolved.	<ul style="list-style-type: none"> • Make sure the hostname is correct and valid. • Make sure the printer is connected to the customer's network. • Check the network settings of the printer in WebTools Express: Primary DNS suffix, Preferred DNS server, Subnet mask, Default Gateway • Check with the System administrator if the DNS server can resolve the hostname to an IPv4 address • If any of previously mentioned checks do not solve the problem, enter the remote host IPv4 address instead of the hostname.
Missing or incorrect path.	<p>Make sure that the path syntax conforms to:</p> <ul style="list-style-type: none"> • hostname/share[/folder/...] or, • <IP_address>/share[/folder/...]
The remote host could not be found.	<ul style="list-style-type: none"> • Make sure that the hostname or IP address is correctly typed. • Make sure that the remote host is up and running and that it is connected to the network.
The remote host is not accessible.	<ul style="list-style-type: none"> • Check that the FTP protocol is enabled on the remote host. • Check that the customer network security policy (firewall/switch) allows the FTP ports. • For FTP destination: check that the FTP server uses the port 21.
The external location cannot be tested: the remote server has reached the maximum number of connections.	<p>The external locations server has reached the maximum number of connections. Check with the System administrator or try again later.</p>

Error message	Action to perform
<p>The remote destination test is aborted, because the time-out period has expired.</p>	<p>Check that the Firewall on the FTP server workstation does not prevent the 'FTP passive mode' connection.</p> <p> NOTE To know more about the FTP passive mode connection, refer to the PlotWave-ColorWave Systems Security manual.</p> <p>Example with FileZilla Server The error message may appear after the installation of FileZilla Server. In order to allow the FileZilla Server application through the Windows Firewall, follow the next steps:</p> <ol style="list-style-type: none"> 1. Open the Windows Firewall window. 2. Click 'Allow a program or feature through Windows Firewall'. 3. Click the 'Allow another app...' (or 'Allow another program...') button. A window named 'Add an app' (or 'Add a program') appears. <p> NOTE Do NOT select 'FileZilla Server Interface' from the list.</p> <ol style="list-style-type: none"> 4. Click the 'Browse...' button. 5. Locate the directory in which you installed FileZilla Server (normally C:\Program Files (x86)\FileZilla Server\). 6. Double click or select 'FileZilla server.exe'. <p> IMPORTANT Make sure you do NOT select 'FileZilla Server Interface.exe'.</p> <ol style="list-style-type: none"> 7. Click 'Open'. The 'Add an app' or 'Add a program' window displays again. 8. Scroll down the displayed list and select 'FileZilla server.exe'. 9. Click 'Add'. The Windows Firewall Allowed apps window displays again. Make sure that 'FileZilla server.exe' is added to the 'Allowed apps (or programs) and features' list. Make sure that it has a check mark in either the 'Private', or the 'Public', or the 'Domain' checkbox (depending on the type of network you want to access). 10. Click 'OK' to close the Windows Firewall window.
<p>The specified path or URL does not exist on the remote host, or the folder name is misspelled.</p>	<ul style="list-style-type: none"> • Check that the path to the destination folder has been correctly typed. • Check that the destination folder exists on the remote host.
<p>The specified user account has no 'write' permission on this location.</p>	<p>For scan-to-file, check that the remote user has "write" permissions on the remote share.</p>

Error message	Action to perform
The external location is full.	Make some space available on the external location for the 'Scan to' operations.
The test of the external location cannot be performed: an internal error has occurred.	Restart the system and try again.

Troubleshoot the creation of an SMB external location (after an error message)

An error message displays to indicate that the creation of the SMB external location failed.

According to the error message, perform the verifications proposed in the next table in order to fix the issue.



Error message	Action to perform
The user name or password is incorrect.	<ul style="list-style-type: none"> • Check the remote user name and the password. If the user name and password are correct, check the syntax of the external location name: <ul style="list-style-type: none"> • - For a remote host user: <hostname>\<username> or <IP_address>\<username> • For a domain user: <domainname>\<username> • Make sure that the destination workstation accepts the NTLMv1 authentication. (Windows environment: Local Security Policy - Security Settings - Local Policies - Security Options - Network Security - LAN Manager authentication level: the setting should be set to any value except 'refuse LM' or 'refuse LM & NTLM')
The remote hostname cannot be resolved.	<ul style="list-style-type: none"> • Make sure the hostname is correct and valid. • Make sure the printer is connected to the customer's network. • Check the network settings of the printer in WebTools Express: Primary DNS suffix, Preferred DNS server, Subnet mask, Default Gateway • Check with the System administrator if the DNS server can resolve the hostname to an IPv4 address • If any of previously mentioned checks do not solve the problem, enter the remote host IPv4 address instead of the hostname.
Missing or incorrect path.	<p>Make sure that the path syntax conforms to:</p> <ul style="list-style-type: none"> • \\hostname\share[\folder\...] or, • \\<IP_address>\share[\folder\...]
The remote host could not be found.	<ul style="list-style-type: none"> • Make sure that the hostname or IP address is correctly typed. • Make sure that the remote host is up and running and that it is connected to the network.
The remote host is not accessible.	<ul style="list-style-type: none"> • Make sure that SMB protocol is enabled on the remote host. • Make sure that the SMB ports are allowed by the firewall. (TCP 445) • Make sure that NetBIOS over TCP/IP is enabled on the destination workstation. (Windows environment: Network and Sharing Center - Change adapter settings; Right-click on Network connection - Properties - IP V4- Properties - General - Advanced - WINS)

Error message	Action to perform
The remote destination cannot be tested: the remote server has reached the maximum number of connections.	The external location server has reached the maximum number of connections. Check with the System administrator or try again later.
The specified path or URL does not exist on the remote host, or the folder name is misspelled.	<ul style="list-style-type: none"> • Check that the share is correctly typed and that the share exists on the remote host. • Check that the path to the destination folder has been correctly typed. • Check that the destination folder exists on the remote host.
The specified user account has no 'write' permission on this location.	For scan-to-file, check that the remote user has "write" permissions on the remote share.
The external location is full.	Make some space available on the external location for the 'Scan to' operations.
The test of the external location cannot be performed: an internal error has occurred.	<ul style="list-style-type: none"> • Restart the system and try again. • Make sure that SMB1 is enabled on the destination workstation. (Windows environment: HKLM\System\CurrentControlSet\Services\LanmanServer\Parameters key).

Troubleshoot the creation of a WebDAV external location (after an error message)

An error message displays to indicate that the creation of the WebDAV external location failed.

According to the error message, perform the verifications proposed in the next table in order to fix the issue.

Error message	Action to perform
Proxy authentication required. Please check the proxy configuration.	<ul style="list-style-type: none"> • Check whether a proxy is required. • Check the proxy settings.
The remote hostname cannot be resolved.	Check whether a proxy is required.
The specified path or URL does not exist on the remote host, or the folder name is misspelled.	<ul style="list-style-type: none"> • Make sure that the path exists. • Make sure that 'Proxy settings' feature is not checked if the WebDAV server does not require an Internet access (local network). • Check the syntax of the WebDAV external location. Make sure it complies with the WebDAV syntax of your Cloud. <p> IMPORTANT For the 'Box.com' Cloud, the WebDAV syntax changed. The new syntax is: <code>https://dav.box.com</code>. You must use the new syntax. It replaces <code>https://apps.box.com/dav</code>.</p>
Missing or incorrect path.	Check the path and the URL syntax. There may be some strange characters in the path, or an incorrect URL.
The user name or password is incorrect.	<ul style="list-style-type: none"> • Check the remote user name and the password. • If the user name and password are correct, check also the "path" syntax.
The external location cannot be tested: the remote server has reached the maximum number of connections.	The external locations server has reached the maximum number of connections. Check with the System administrator or try again later.
The specified user account has no 'write' permission on this location.	<ul style="list-style-type: none"> • For scan-to-file, check that the remote user has "write" permission on the remote host. • Check the syntax of the WebDAV external location. <p> NOTE Replace <code>http://</code> by <code>https://</code>.</p>
The external location is full.	Make some space available on the external location.
The test of the external location cannot be performed: an internal error has occurred. Please restart the system and try again.	<ul style="list-style-type: none"> • Check the URL syntax entered in the Path setting. • Check that proxy settings are not checked if the WebDAV server does not require an Internet access (local network). • Restart the system and try again.

Configure the printer settings

Configure the regional settings

Purpose

The regional settings are configured during the installation of your printer. When you want to change the initial configuration, you can do this under the [Regional settings].

Define the regional settings for the printer in the following order:

- [First language] and [Second language] of the user panel
- [Measurement unit]
- [Time zone]

When you change the [Time zone] you must reboot the system first, before you set the [Current date and time].

- [Current date and time]
- [Time format]



NOTE

Every time you change the [Measurement unit], the controller recalculates the values from millimeter to inches and vice versa. If you reverse to the original value of this setting a slight calculation difference can occur due to rounding differences.

Procedure

1. Open the [Preferences] - [System defaults] tab.
2. Click on [Edit] in the [Regional settings] section, or click on the setting you want to edit, for example [First language].
3. Modify the settings. You can choose between:
 - settings that are commonly used in the USA
 - or settings that are commonly used in the rest of the world.
4. Click [OK] to confirm, or [Cancel] to reject your entries.

Configure the user session time-out

Introduction

The user panel returns automatically to the home screen and its default configuration. You can set a time limit for the user session.

When to do

Define a suitable time-out period that does not interfere with the print productivity.

Procedure

1. Open the [Security] - [Configuration] tab.
2. Click on [Edit] in the [User access configuration] section or click on the [User session time-out] setting.
3. Enter a time period .
4. Click [Ok] to confirm, or [Cancel] to reject your entries.

Configure the working hours

Introduction

You can define the working hours of the printer in WebTools Express.

Enable [Automatic on] first, to let the printer wake up automatically. Define the working days with the [First workday] setting, for example 'Monday', and [Last workday] setting, for example 'Friday'. And set the wake up time and shut down time with the [Start-up time] and [End of workday time] settings, for example '06:30' and '19:00'.

That way the printer turns on and off automatically, at the set day and time.



NOTE

Even if [Automatic on] is disabled, the [End of workday time] setting is active and causes the printer to automatically switch off at the selected time (due to power saving regulations, the printer must always shut down once in twenty-four hours).



NOTE

If the printer was manually powered on outside the defined working hours, the printer will automatically switch off instead of going to sleep mode after the selected [Go into sleep mode after] period has elapsed.

Procedure

1. Open the [Preferences] - [System defaults] tab.
2. Click on [Edit] in the [Printer properties] section.
3. Set the [Automatic on] setting to [Enabled].
4. Set the [Start-up time], [End of workday time], [First workday] and [Last workday] settings according to your preferences.
5. Click [Ok] to confirm, or [Cancel] to reject your entries.

Result

The printer now wakes up automatically, and is active during the preferred time frame on the set days.

Configure the energy save modes

Introduction

The ColorWave 3600 offers two energy save modes that you can set if the printer is idle for a defined period. The configuration of the timers prevents unnecessary power consumption. You can adjust the value of the timers.

When to do

Sleep mode timer (Default value 45 minutes).

The printer uses minimal energy because the power supply of the printer is turned off. The power supply of the controller remains on. The printer needs to warm up when it wakes up from the sleep mode.

Energy save mode timer (Default value 1 minute).

Both the printer and the controller remain turned on. The printer uses less energy than in normal operating mode, but the printer uses more energy than in sleep mode. The advantage of the energy save mode over the sleep mode is that the printer usually needs just a few seconds to wake up.



NOTE

If the printer was manually powered on outside the defined working hours, the printer will automatically switch off instead of going to sleep mode after the selected [Go into sleep mode after] period has elapsed.



NOTE

The value you set for the sleep mode timer must be higher than the energy save mode value. If the value of the sleep mode is lower than the energy save mode, the printer skips the energy save mode and goes into sleep mode. The power consumption will be lower but it will also take the printer a bit longer to wake up again.

Procedure

1. Open the [Preferences] - [System defaults] tab.
2. Click on [Edit] in the [Printer properties] section, or click on the [Go into sleep mode after] setting or the [Go into energy saving mode after] setting.
3. Enter a new value.



NOTE

If you access the Edit window by clicking the value of the setting you want to change, the Edit window displays the minimal and maximal value you can select.

4. Click [Ok] to confirm, or [Cancel] to reject your entries.



NOTE

When the printer is in the energy save mode, there are several ways to activate the system.

- press the wake-up button on the user panel
- send a print job
- insert an original in the scanner

Configure the media request time-out

Introduction

The user panel displays a message with a media request when the requested media is not available on the printer.

- When the [Media request timeout] setting is disabled, the media request will be displayed on the user panel until it is resolved.
- When the [Media request timeout] setting is enabled (default), you can enter a media request time-out value in seconds. When the media request is not resolved within the media request time-out period, the [Action after media request timeout] setting determines whether the printer either deletes the job from the Job queue or puts the job in attention state.

Procedure

1. Open the [Preferences] - [System defaults] tab.
2. Click on [Edit] in the [Printer properties] section or click on the [Media request timeout] setting.
3. When you enable the setting, you must enter a time period as well. If you choose to disable the setting, the time period will not be adjustable.
4. Click on the [Action after media request timeout] setting.
5. Select [Put the job on attention state] or [Delete the job].
6. Click on [Ok] to confirm or [Cancel] to reject your entries.

Configure the core size of the media rolls

Introduction

The standard core size of the media rolls for the ColorWave 3600 is 3 inch.

If you also use 2 inch cores, enable the setting [Rolls with 2-inch core diameter].

If [Rolls with 2-inch core diameter] is enabled, the printer will ask the used core size when loading a media roll.

Procedure

1. Open the [Configuration] - [Printer setup] tab.
2. Click on [Edit] in the [Media] section, or click on the [Rolls with 2-inch core diameter] setting.
3. Select the correct value.
4. Click [Ok] to confirm, or [Cancel] to reject your entries.

Configure the pen settings

Introduction

You can define the pen settings in the application that you use to create a drawing with. When the pen settings are not defined in the application, you can configure the default pen settings in WebTools Express.

Procedure

1. Open the [Preferences] - [Print job defaults] tab.
2. Go down to the list of pen numbers.
3. Click on the value of the pen number that you want to change.
The pen settings window opens. You can configure the color, width and pattern for this pen.
4. Click on [Ok] to confirm or [Cancel] to reject your entries.

Configure the roll-to-roll mode in WebTools Express

Introduction

When you want to use the take-up unit, your printer has to be in the roll-to-roll mode. When you enable the roll-to-roll mode, the printer will not cut between pages. You can also configure the roll-to-roll mode on the user panel.



NOTE

- When the roll-to-roll mode is enabled, each print job is delivered to the [Back output]; even when you set the [Top delivery tray] as output location for your prints.
- To calibrate the printer the roll-to-roll mode must be disabled.
- When the printer is in roll-to-roll mode, you have to cut the media before you can replace a toner cartridge.

Procedure

1. Open the [Preferences] - [System defaults] tab.
2. Click on [Edit] in the [Job management] section, or click on the [Roll-to-roll mode] setting.
3. Select [Enabled] or [Disabled].
4. Click [OK] to confirm, or [Cancel] to reject your entries.

Configure the finishing settings

Set the Finishing Assistant

Introduction

This setting is only available when a folder is installed .

The [Finishing Assistant] can automatically detect the legend (if present) of a drawing and rotate and align the drawing so the legend will be on the cover page of the fold package. If no legend can be detected the print is delivered unfolded.

When enabled, the [Finishing Assistant] overrules the default rotation and alignment settings for folded output.

Procedure

1. Open the [Preferences] - [Print job defaults] tab.
2. Click on [Edit] in the [Layout] section, or click the [Finishing Assistant] setting.
3. Select [Enabled] if the printer must automatically detect the legend of your drawings and fold the drawings correctly.
4. Click [Ok] to confirm, or [Cancel] to reject your entries.

Fold settings for custom fold templates

Introduction

You can set the fold options in the fold template under the [Preferences] - [Fold] tab. For more information on how to create a template see, [Create a new template on page 111](#).

When you set the fold options, make sure you set them accordingly to operate the folding device in a correct way. Use the settings overview explanation below.

When you have selected [Template source] - [Custom template], the following settings are available.

Folding

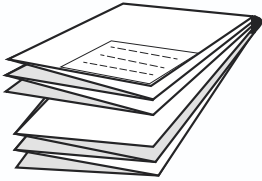
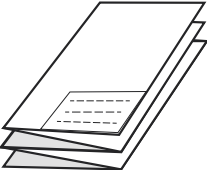
[Folding package]	Description	Example
[Full fold]	Folded with first (Z-fold) and second fold (cross fold).	
[First fold only]	Folded only with the first fold (Z-fold).	



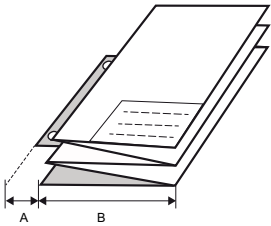
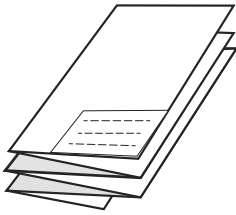
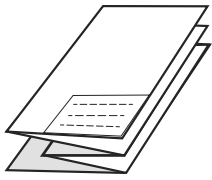
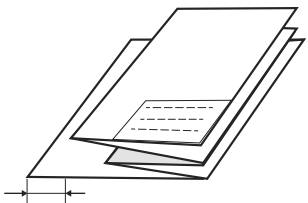

NOTE

The [Reinforcement] setting is only available when the selected finishing device contains a reinforcement unit.

[Reinforcement]	Description	Example
[Enabled]	<p>Glue a pre-punched strip to the back-side of the folded package.</p>  <p>NOTE</p> <ul style="list-style-type: none"> • The reinforcement strip uses a binding size of 12mm (A). • The package width size (B) excludes the [Binding edge size] (A). So the back panel consists of the package width size plus the binding edge size (A+B). • Only possible when [Folding method] is [With same size back]. 	
[Disabled]	No glued strip.	
[Folding method]	Description	Example
[Compact fold]	Folded package, but the last fold (backside) is shorter.	
[With same size back] (DIN-B).	Folded package, but the last fold (rear) is over the full width. The previous fold could be shorter.	
[With binding edge] (DIN-A).	Folded package, but the last fold (rear) has additional width. The previous fold could be shorter.	

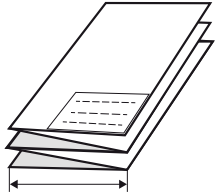
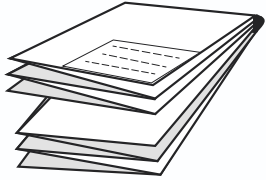
Package size

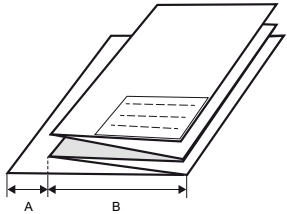
[Package size]	Description	Example
[Width]	<p>Defines the fold distance of the Z-fold.</p> <p> NOTE Note that the package width size excludes the [Binding edge size]. So the back panel consists of the package width size plus the binding edge size (A+B).</p>	
[Height]	<p>Defines the fold distance of the cross fold.</p> <p>This only applies to the folding device in [Full fold] mode.</p>	
[Binding edge size]	<p>Defines how much the binding is outside the package. You can select a value depending on the folding device.</p> <p> NOTE</p> <ul style="list-style-type: none"> • The package width size (B) excludes the [Binding edge size] (A). So the back panel consists of the package width size plus the binding edge size (A+B). • Only visible when the selection in [Folding method] is set to [With binding edge]. 	

Delivery



NOTE

Note that the available options depend on the chosen [Folding package] value.

[Fold delivery]	Description
[Belts]	Defines that the output will be delivered on the belt unit (only for [Full fold] and when the belt unit is installed).
[Stacker]	Defines that the output will be delivered at the stacker (only when a stacker is installed).
[First fold output]	Defines that the output will be delivered at the first fold section (only for [First fold only]).

Fold settings for embedded fold templates

Introduction

You can set the fold options in the fold template under the [Preferences] - [Fold] tab. For more information on how to create a template see, [Create a new template on page 111](#).

When you set the fold options, make sure you set them accordingly to operate the folding device in a correct way.

The embedded template determines the delivery location.



NOTE

It is advised to enter a template name that makes the template recognizable to the user.

When you have selected [Template source] - [Template embedded in folding device], the following settings are available.

	Description
[Embedded template ID]	The ID number of the program that is embedded in the folding device. On the folding device you can find a complete list of the available folding programs.
[Top of folded package]	Defines the position of the legend when a portrait sheet enters the folding device (see Default fold templates on page 144).
[Top of folded package when printing landscape]	Defines the position of the legend when a landscape sheet enters the folding device (see Default fold templates on page 144).

Default fold templates

Introduction

In case you have a folding device configured as finishing device ([Folder Professional 6011], [Folder Professional 6013 (with reinforcement unit)], or [Folder Express 3011]) there are factory installed fold templates available.



IMPORTANT

The [Top of folded package] setting or the [Top of folded package when printing landscape] setting defines the position of the legend when a sheet enters the folding device. This is to make sure that after folding, the legend is on top of the folded package.

For example, when the [Top of folded package] is [Top right], the sheet should enter the folding device as indicated below.

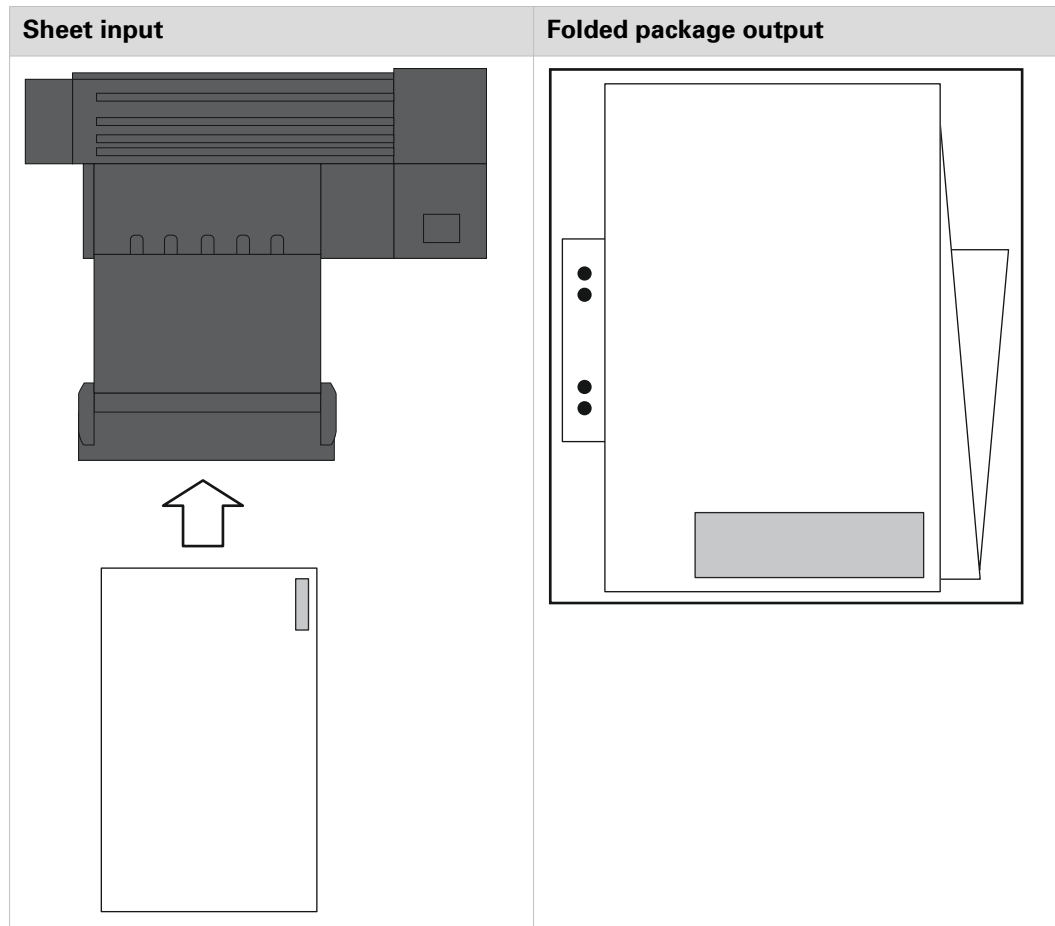

Select the [Preferences] - [Fold] tab in WebTools Express to get an overview of the available fold templates.

Adjust the print quality and print productivity

Set the print quality

Introduction

You can use Webtools Express to set the print quality. The choice of the print quality affects the speed of the job and the toner coverage.

[Print quality]	Number of passes	resolution Dpi
[High speed]	1	300x300
[Economy - fast]	1	300x300 for B/W 450x300 for color
[Production]	2	600x600
[Quality]	4	600x600

In the print quality range from [High speed] to [Quality] the quality increases while the speed decreases.

Set the print quality in the print job default settings

1. Open the [Preferences] - [Print job defaults] tab.
2. Click on [Edit] in the [Image] section or click on the [Print quality] setting.
3. Select [Print Assistant] (OPA) to automatically select the best print quality based upon the content of the file or manually choose a print quality yourself from the list in the table above.
4. Click [OK] to confirm, or [Cancel] to reject your entries.

Set the print quality in the copy job default settings

1. Open the [Preferences] - [Copy job defaults] tab.
2. Click on [Edit] in the [Custom image preset for copy] section or click on the [Print quality] setting.
3. Select [Automatic] to automatically select the best print quality ([Economy - fast], [Production], [Quality]) based upon the content of the file or manually choose a print quality yourself from the list in the table above.
4. Click [OK] to confirm, or [Cancel] to reject your entries.

Set the long plot mode

Introduction

When the long plot mode is enabled, the system will be able to print TIFF, HP-GL, HP-GL2 and HP-RTL plots up to 175 meter with good quality. Transformation such as scaling and rotating are not guaranteed in this mode. For other formats such as PS and PDF, the system will print in "normal" mode, with a maximum plot length of 22 meter.

For the printer to be able to print long prints, the print quality can be reduced.

Procedure

1. Open the [Preferences] - [Print job defaults] tab.
2. Click on [Edit] in the [General (non-PostScript/PDF)] section or click on the [Long plot mode] setting.
3. Enable or disable. The setting is enabled when you check the box.
4. Click [OK] to confirm, or [Cancel] to reject your entries.

Set the automatic roll switch

Introduction

In WebTools Express you can select an automatic roll switch setting:

- [Roll empty: when a specific roll number is set]

You can choose one of the following actions:

- [Switch to a similar roll (same type, same size)]

The printer automatically continues printing on an identical (size and media type) roll when the selected roll runs out of media. If no identical roll is available, the job is stopped and the printer requests to load new media.

- [Always ask to replace the empty roll]

The job is stopped and the printer requests to load new media.

This setting has no influence on jobs for which only a media size was selected. For these jobs, the Media Selection Policy determines if a new roll can be selected.

Procedure

1. Open the [Preferences] - [System defaults] tab.
2. Click [Edit] in the [Printer properties] section, or click on the setting [Roll empty: when a specific roll number is set].
3. Select the desired action.
4. Click [Ok] to confirm, or [Cancel] to reject your entries.

Set the spool threshold

Introduction

When the job memory is full the printer cannot receive new jobs, therefore it is necessary to partly empty the memory. Set the [Spool threshold] setting to define the spool capacity for your jobs.

You can choose one of following values:

- [Low]
Select this value if you have several small print jobs and you want to allow a higher capacity.
- [Normal]
This is the default setting. Select this value if you have both small and large print jobs.
- [High]
Select this value when you have more large print jobs, and you want to reduce the risk of having to abort the file transfer due to a full job memory.

Procedure

1. Open the [Preferences] - [System defaults] tab.
2. Click on [Edit] in the [Printer properties] section or click on the [Spool threshold] setting.
3. Select [Low], [Normal], or [High].
Select [Low] if print productivity is an important factor.
4. Click [OK] to confirm, or [Cancel] to reject your entries.

Set the rotation mode

Introduction

If you want to turn an image, you can use the rotation settings. The setting allows you to turn the image according to predefined rotation values or you can let the printer perform the rotation automatically.

Choose one of the following values:

- [No rotation]
- [90°]
- [180°]
- [270°]
- [Short edge first]
- [Long edge first]
- [Short edge first with additional 180° rotation]
- [Long edge first with additional 180° rotation]
- [Automatic media saving]
- [Automatic media saving with additional 180° rotation]

Procedure

1. Open the [Preferences] - [Print job defaults] tab.[Print job defaults]
2. Click on [Edit] in the [Layout] section or click on the [Rotation] setting.
3. Choose one of the values.
Select [Automatic media saving] or [Automatic media saving with additional 180° rotation] when the print productivity is an important factor.
4. Click [Ok] to confirm, or [Cancel] to reject your entries.

Set the alignment mode

Introduction

When you want to shift the image on the sheet, you can change the alignment mode. With the alignment mode, you can also optimize the print productivity as you reduce the distance the print carriage has to travel. You can, for instance, align the image to the top right-hand corner of the sheet.

You can choose the following alignment settings:

Alignment mode		
[Top left]	[Top]	[Top right]
[Left]	[Center]	[Right]
[Bottom left]	[Bottom]	[Bottom right]

Procedure

1. Open the [Preferences] - [Print job defaults] tab.
2. Click on [Edit] in the [Layout] section or click on the [Alignment] setting.
3. Select the correct value.
Select [Top right] when the print productivity is the most important factor.
4. Click [OK] to confirm, or [Cancel] to reject your entries.

Set the PDF render engine

Introduction

Select [APPE: Adobe PDF Print Engine] for best quality and compatibility with for example Adobe Acrobat. Select [Adobe PostScript interpreter] for compatibility with POWERSync-based PlotWave products.

Both choices of the [PDF render engine] support wipeout correction.

Procedure

1. Open the [Preferences] - [Print job defaults] tab.
2. Click on [Edit] in the [PDF - General] section, or click on the [PDF render engine] setting.
3. Select the correct value.
4. Click [Ok] to confirm, or [Cancel] to reject your entries.

Set transparency flattening for PDF

Introduction

In WebTools Express, you can select a setting to flatten transparency information in a PDF document before printing. The setting is used for PDF documents containing transparency information only.

You can choose between the following values:

- [Quality]
Select this value if print quality is an important factor. The processing speed slows down and more memory is required.
- [Speed]
Select this value if PDF processing performance is more important than print quality. Large and complex PDF files are processed faster and use less memory.



NOTE

You can only change the transparency flattening, when the [PDF render engine] setting is set to [Adobe PostScript interpreter]. You can find this setting under [Preferences] - [Print job defaults] - [PDF - General].

Procedure

1. Open the [Preferences] - [Print job defaults] tab.
2. Click on [Edit] in the [PDF - General] section or click on the [Transparency flattening] setting.
3. Select [Quality] or [Speed].
4. Click [OK] to confirm, or [Cancel] to reject your entry.

Set the Print Assistant behavior

Introduction

This setting is only used when the [Print quality] is set to [Print Assistant].

The [Print Assistant] decides what print setting must be used, based on the average toner coverage of the print.

By analyzing the image the Print Assistant can automatically determine the best print setting to be used for each document. The [Print Assistant behavior] setting allows you to tune the outcome of the Print Assistant's analysis to fit your specific needs. The thresholds for switching from one mode to another can be altered by the [Print Assistant behavior]¹. In this way the Key Operator can fine-tune the [Print Assistant] to optimize further speed and quality to his personal needs. The [Print Assistant] will be the default mode for the ColorWave 3600 .

¹ The number in the [Print Assistant behavior] represents a position on a scale from 0 to 100. A higher number means an increased preference for print quality, a lower number means an increased preference for print speed.

Procedure

1. Click [Preferences] - [System defaults].
2. Click [Edit] in the [Printer properties] bar or click on the [Print Assistant behavior] setting.
3. Set the to '0' if the print productivity is the most important factor.
Set the to '100' if the print quality is the most important factor.
4. Click [Ok] to confirm your entries or [Cancel] to reject your entries.

Optimize the print productivity

Introduction

When you load media, always make sure that you install and define the correct media type and size on the printer. Depending on your needs, you can optimize the print productivity in various ways.

When productivity with different media sizes is the most important requirement.	
1	Load up to 4 media rolls on the printer with different media sizes and the same media type.
2	Use the [Landscape] orientation to print a job on a media size that is one size bigger than the media defined on the system. For example, D prints in landscape on E and C prints in landscape on D. You are not required to cut the media by hand.
3	Use the [Long edge first] setting or the [Long edge first with additional 180° rotation] on the user panel or WebTools Express to rotate the orientation automatically.

When productivity is the only important requirement.	
1	<p>Load and define two or more media rolls on the printer with the same media size and the same media type.</p> <p> NOTE When roll 1 is empty, the printer switches automatically to roll 2. When a specific roll number is set in the job, the behavior depends on the setting [Roll empty: when a specific roll number is set].</p>

About color management

What is color management?

Definition

The color management settings help you to reproduce the colors of your input as precisely as possible on the printed output.

With the color management settings you define how to convert the color-information of the file you want to print (input color space; RGB, CMYK or Grey color space) to the output color space of the ColorWave 3600 (CMYK color space). This conversion can require approximations in order to preserve the image's most important color qualities.

To be able to reproduce colors it is important to define the following.

- Input profile / Standardization
- Color feel / Rendering intents
- Output profile

What is an input profile / standardization?

Definition

An input profile / standardization defines what color space you must use to interpret the color information of the file you want to print in a correct manner.

The main input profiles (color spaces) are the following.

- **RGB**

The RGB color space is based on the RGB color model. RGB (Red, Green, Blue) is a suitable color model for computer graphics because the human visual system operates in a similar manner.

The RGB color space is an **additive** color space, where you can mix colors based on light. You can create white light if you add equal parts of each of the three primary colors: red, green, and blue. All three colors are required to produce white and the absence of all three produces black. In additive mixing, the RGB colors are the primary colors and cyan, magenta, and yellow (CMY) are the secondary colors.

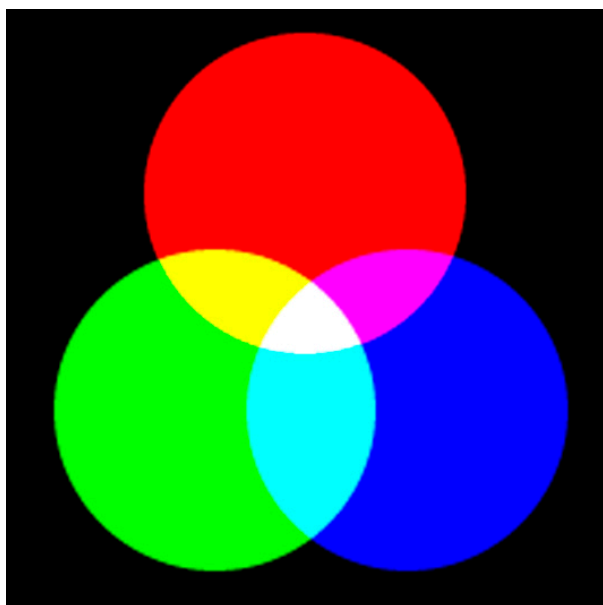

- **CMYK (Colors you print)**

The CMYK color space is based on the CMYK color model. The CMYK (Cyan, Magenta, Yellow and Black color space is a **subtractive** color space, where you can mix colors based on subtracting light energy from the spectrum. The CMY toners are used to create RGB colors. All three inks are required to produce black and the absence of all three produces white. In subtractive color mixing the CMY colors are the primary colors and RGB are the secondary colors.

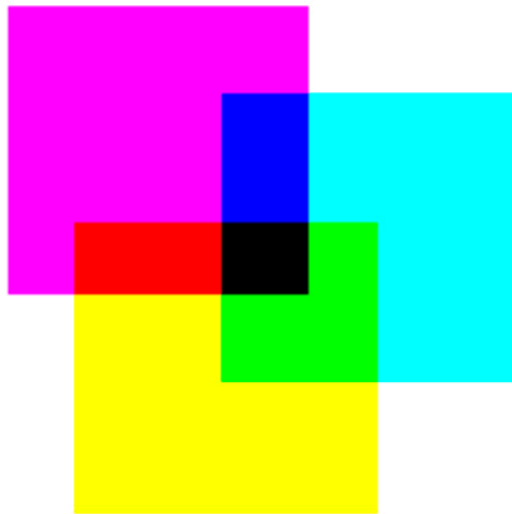

- **Gray**

In the grayscale (color) space only information about the lightness is given. Lightness can range from a minimum of 0 (black) to 100 (white).

You can define the input profile if you use the [Color feel] setting [Graphics colors].

The table below gives an overview of the possible input profiles / standardization settings.

Input profile / standardization	Description
RGB - [sRGB]	Use this setting to indicate the color space of a standard computer monitor. sRGB is the most frequently used RGB color space, especially in consumer grade digital cameras. sRGB is acceptable for most consumer applications. The sRGB design allows easy previewing on a standard computer display.
RGB - [Adobe RGB]	This setting indicates an RGB color space developed by Adobe in 1998. Adobe RGB has a larger gamut than sRGB. Adobe RGB is included in more medium-range digital cameras, and many professional graphic artists prefer Adobe RGB for its larger gamut.
CMYK - [Euroscale coated]	This setting indicates an old offset press standard, formerly used in Europe to print separations and proofs on coated media.
CMYK - [Euroscale uncoated]	This setting indicates an old offset press standard, formerly used in Europe to print separations and proofs on uncoated media
CMYK - [US Web coated (SWOP)]	This setting indicates an old offset press standard, formerly used in the US to print separations and proofs on coated media.
CMYK - [US Web uncoated]	This setting indicates an old offset press standard, formerly used in the US to print separations and proofs on uncoated media.

Input profile / standardization	Description
CMYK - [ISO Coated v2 300% (ECI)]	This setting indicates an offset press standard, frequently used in Europe to print separations and proofs on coated media. Based upon Fogra39 with 300% ink limit.
CMYK - [ISO Coated v2 (ECI)]	This setting indicates an offset press standard, used in Europe to print separations and proofs on coated media. Based upon Fogra39 with 330% ink limit.
CMYK - [PSO Uncoated ISO12647 (ECI)]	This setting indicates an offset press standard, used in Europe to print separations and proofs on uncoated media. Based upon Fogra47.
CMYK - [Uncoated FOGRA29]	This setting indicates an offset press standard, used in Europe to print separations and proofs on uncoated media. Based upon Fogra29.
CMYK - [GRACoL2006 Coated1v2]	This setting indicates an offset press standard, frequently used in the US to print separations and proofs on coated media grade 1.
CMYK - [SWOP2006 Coated3v2]	This setting indicates an offset press standard, used in the US to print separations and proofs on coated media grade 3.
CMYK - [SWOP2006 Coated5v2]	This setting indicates an offset press standard, used in the US to print separations and proofs on coated media grade 5.
Gray[None (no profile used)]	Use this setting to directly transform the grayscale info to black toner usage only.
Gray[sGray]	Use this setting to transform the grayscale info based upon the sGray profile (lightness scale sRGB with gamma 2.2) to CMYK toner usage.
Gray[Adobe Gray 20%]	Use this setting to transform the grayscale info based upon the Adobe Gray 20% profile (Adobe specific dot gain 20%) to CMYK toner usage.

What is color feel?

Definition

With the [Color feel] setting you can fine-tune the **look and feel** of the printed output.

The [Color feel] setting defines the color space conversion method.

[Color feel]	Description
[CAD colors]	<p>Use this setting to get a print with bright, saturated colors.</p> <p>Advised for vector drawings (like HP-GL).</p> <p>All primary and secondary colors are clean, because they are printed with pure inks. This is clearly visible if you look at the color yellow that is printed with yellow ink only.</p> <p>An increase in coverage results in (almost) the same increase in ink.</p> <p>The blue color is not purplish but nice blue.</p> <p>This mode is preferred for CAD drawings created with applications like AutoCAD or ArcView.</p> <p>Photos printed in this mode will look dull and grayish.</p>
[Graphics colors]	<p>Use this setting to get a print with photo-realistic colors. Advised for photos or graphic art presentations.</p> <p>If you select [Graphics colors] you can also adjust the advanced Color Management settings.</p> <ul style="list-style-type: none"> • [Graphics colors: RGB input color profile] • [Graphics colors: CMYK input color profile] (only for TIFF and JPEG files or for PostScript and PDF files) • [Graphics colors: Grayscale input color profile] (only for PostScript and PDF files) • [Graphics colors: rendering intent]
[None, managed by application]	<p>Use this setting if your color management is completely done by the application that generated the print file.</p> <p>If color management is not handled correctly by the application, possible problems are:</p> <ul style="list-style-type: none"> • - blue will be purplish (like in most inkjet printers) • - raster-file information (like photos) will look dull and dark.

What are rendering intents?

Definition of rendering intents

Normally the color space of a print file is larger than the ColorWave 3600 color space. In other words, the input color space is larger than the output color space. Consequently some of the defined input colors will be outside the ColorWave 3600 color space. These "out-of-gamut colors" are called a gamut mismatch.

When a gamut mismatch occurs, the rendering intent setting decides what qualities of the image it should prioritize. The rendering intent setting preserves one property of color at the expense of other color properties.

Rendering intent: Perceptual (photo)

This setting optimizes the output to produce best results for photos, artwork, GIS or images. Perceptual rendering tries to preserve some relationship between out of gamut colors, even if this results in inaccuracies for in-gamut colors.

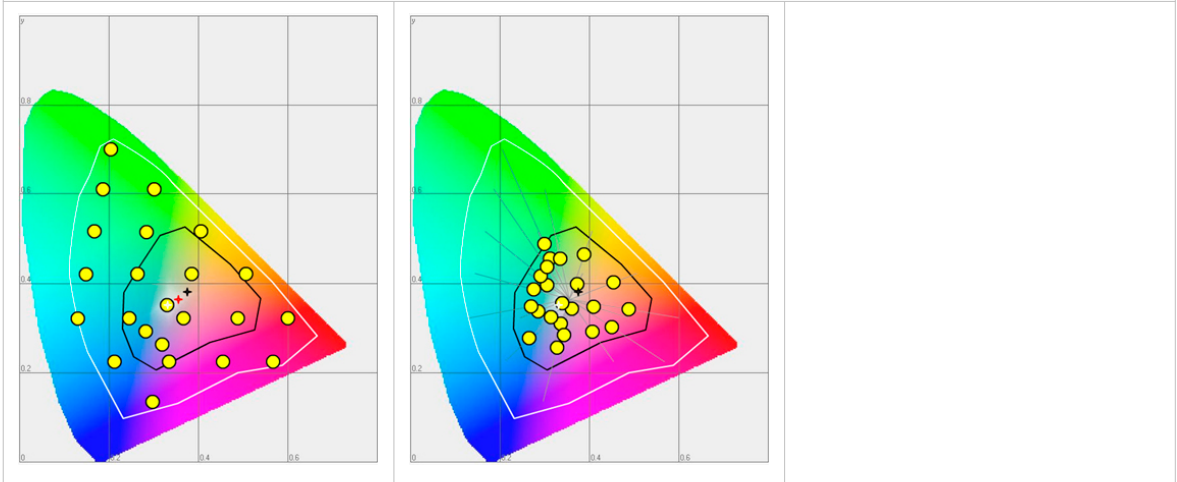

Rendering intent: Saturation (business graphics)

This setting optimizes the output of bright, saturated colors. Saturation rendering intent preserves saturated colors, and is advised if you try to keep color purity in computer graphics. Pure saturated colors in the original RGB device will still be saturated colors in the output color space, even if this results in relatively more extreme colors. Saturation rendering intent is not advised for photos, because this setting does not try to keep color realism. The color saturation can come at the expense of changes in hue and lightness, which is normally an unacceptable trade-off for photo reproduction. You can also use saturation rendering intent to prevent visible dithering if you must print computer graphics on a printer. It is not possible to prevent all dithering, because printers never can match every color. Saturation rendering intent can minimize dithering if the color is very close to pure.

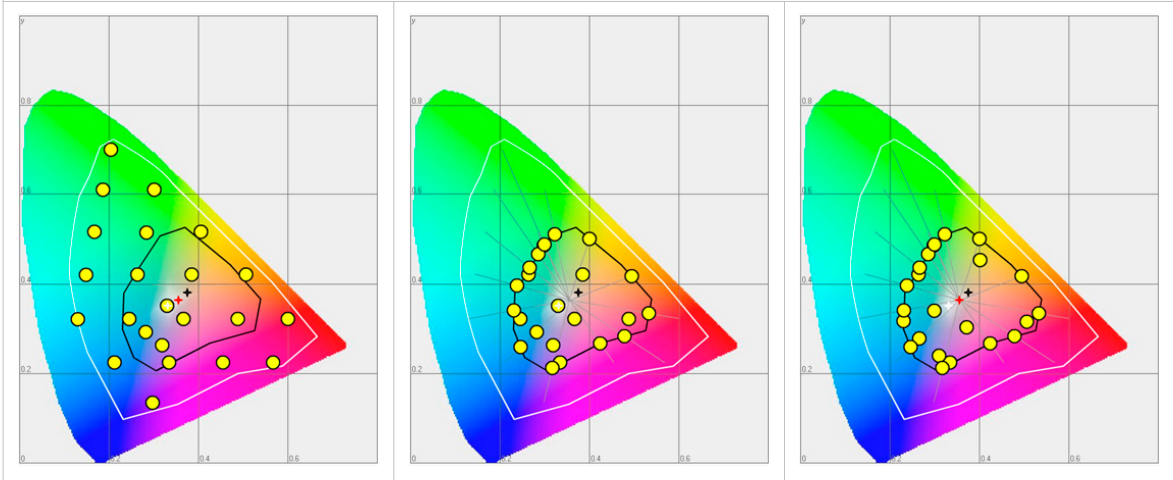

Rendering intent: Relative colorimetric

Relative colorimetric keeps an almost exact relationship between in gamut colors, even if this clips out of gamut colors.

The relative colorimetric rendering method replaces the colors to align the old white point (the location of the most pure and light white in a color space) with the new white point and to keep the relative positions of the colors. The Relative colorimetric rendering intent is advised for logos, spot colors or PowerPoint presentations, but the loss of contrast can be a problem with photos and images.

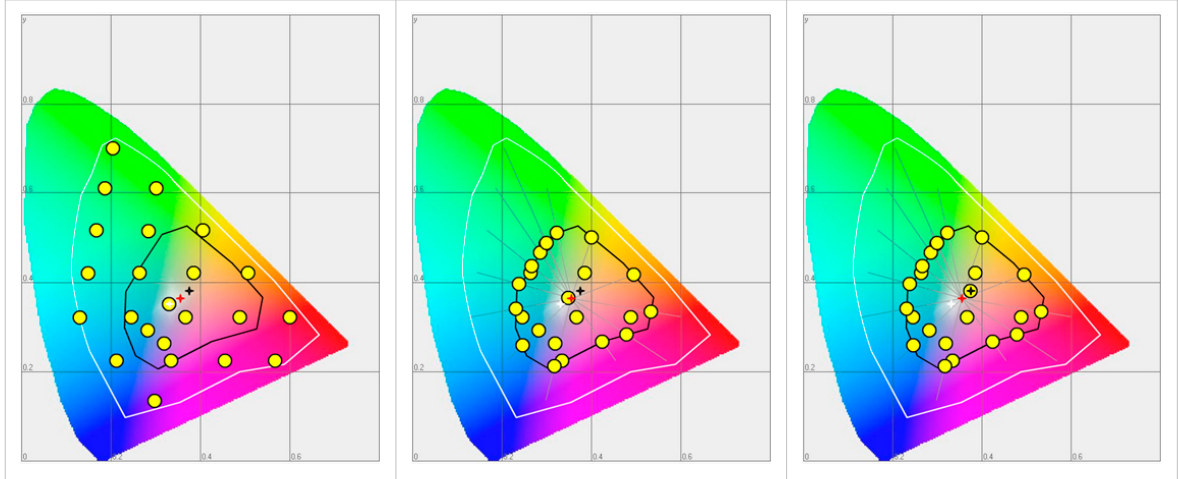

Rendering intent: Absolute colorimetric

Absolute colorimetric is similar to relative colorimetric, but uses a different method to handle the white point.
Absolute and relative colorimetric both keep gamut colors and clip those out of gamut, but absolute colorimetric also keeps the white point.
Absolute colorimetric is advised for "proofing" applications, that require a good color match, but also emulation of paper white. As a result of that, white areas can become yellowish, because the printer tries to emulate the whitepoint of the input profile.
This setting provides the highest accuracy in rendering RGB colors into CMYK colors, including rendering the source's white.



NOTE

You can see the minor level of blue of the monitor background as a bluish white in the lightest tones of the printed output. A minor yellow tone can occur in the white tones of a PDF/TIFF original or an HP-GL type document.

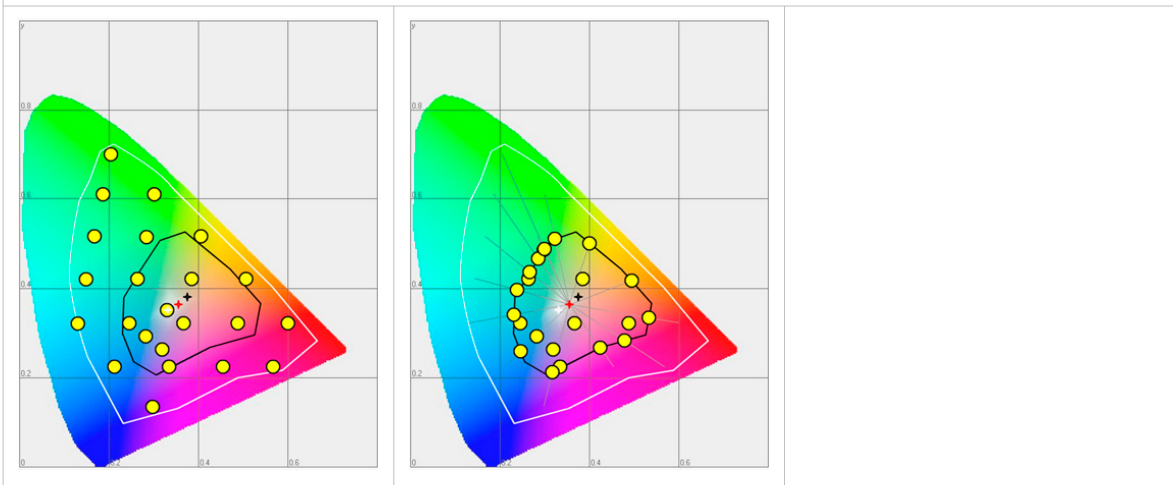

What is an output profile?

The output profile is used to adjust the converted CMYK color space, depending on the output device (via the ColorWave 3600 Printer Calibration Module) and the media type you select (via the OMP Media Profile file).

The output profile is applied automatically, but it is important that you load the correct media on the ColorWave 3600 and that the correct OMP-file is available on the controller.

(see [Configure the media profiles on page 180](#))

(see [Install a media profile on page 181](#))

Color management settings in WebTools Express

Depending on the type of file you want to print, the ColorWave 3600 offers different color-information conversions. You can select the color management settings, that give the best results for the color-information conversion.

Open the [Preferences] - [Print job defaults] tab to define the default color management settings per file type ([HP-GL/2 - Color management settings], [PostScript - Color management settings], [PDF - Color management settings], or [TIFF and JPEG - Color management settings]).

The Driver Select for Microsoft® Windows® and the Publisher Select job submission application offer the same color management settings, but now file type independent.



NOTE

It is only important to know what the file type of your print job is, if you want to use or must use the color management settings defined in WebTools Express. If you define the color management settings in your Driver Select for Microsoft® Windows® or the Publisher Select job submission application the color management settings are automatically assigned to the correct file type (the color management settings defined in WebTools Express are overruled).

Color management settings and job submission

The way in which you submit a print job to the printer defines in most cases the file type of the document. If you use a printer driver, the original file type will be changed by the driver into a standard file type.

When there is no job ticket or when the job ticket does not include a color management setting, the printer checks the file type of the document and based on the file type the printer applies the default color management settings of Webtools Express.

If you use FTP, LPR, Publisher Select or Publisher Express to send a job to the printer, the file type is not changed. The file is sent to the printer the way in which it was saved in the application you used to create or edit the file. If there is no embedded color profile present in the document, the printer checks the file type of the document and based on the file type the printer applies the default color management settings of Webtools Express.

If you want to use the embedded color profile for your print job (for example, embedded profile created with Adobe® Illustrator) you can choose between 2 options. You can use the Driver Select for Microsoft® Windows® where you can indicate to follow the color settings managed by the application. You can also send the job via FTP, LPR, Publisher Select (choose 'Document's color feel') or Publisher Express. If the controller can recognize the embedded color profile, it will be applied. If the embedded color profile cannot be recognized, the controller applies the default color settings managed by Webtools Express.

The table below gives an overview of the relation between the job submission method, the file type and the color management settings

Job submission method	File type	Color management settings
Driver Select for Microsoft® Windows®	The driver converts all files into HP-GL/2	You can define the color settings in: <ul style="list-style-type: none"> • The printer driver. • Webtools Express, by choosing the printer's default in the driver settings. • The application, by choosing the setting [None, managed by application] in the driver

Job submission method	File type	Color management settings
LPR FTP Publisher Select Publisher Express	<p>The documents are sent to the printer without being converted to another file type.</p> <p>The controller recognizes the following file types.</p> <ul style="list-style-type: none"> • HP-GL - .hp, .hpg, .hpgl • HP-GL/2 - .hp2 • HP RTL - .rtl • CALS - .cls, .cal • NIRS - .nir, .nif • CalComp - .cc, .906, .907, .951, .crf, .pci • Edmics (C4) - .c4 • TIFF - .tif • PostScript 3 - .ps (licensed) • PDF - .pdf (licensed) • JPEG - .jpg, .jpeg 	<p>Depending on the file type of the job, the default settings of one of the 4 file type paths in Webtools Express is used when there is no embedded color profile present in the file. Use Webtools Express to adjust the color settings for the print job.</p> <p> NOTE When you use Publisher Select, configure the color management settings in Publisher Select.</p>

Priorities in the color management settings

When you want to print a document in color on the ColorWave 3600 the color information that is defined in the files can be set in the different steps of the process from document creation to document production. In order to get the best output results you need to be aware of these methods to define the color information of the document you want to print.

The color information that you can create in the various steps described below each have a different priority. When you create a document that you want to print in color, the priority of the color settings is also illustrated in the table below.

Stages in the process of making a color print	Priority
<p>Document</p> <p>The color settings are already embedded in the document (only applicable for PDF files).</p>	1
<p>Application</p> <p>The color settings can be defined in the application that you use to create or edit the document.</p> <p>You can set the following parameters in the application.</p> <ul style="list-style-type: none"> • Set color or black and white. • Define the input profile, RGB input data or CMYK input data. (see What is an input profile / standardization? on page 156) • Define the rendering intents. (see Definition of rendering intents on page 160) 	2
<p>Publisher Select</p> <p>The color settings can be defined in Publisher Select.</p> <p>You can set the following parameters in Publisher Select:</p> <ul style="list-style-type: none"> • Set color or black and white. • Define the input profile, RGB input data or CMYK input data. (see What is an input profile / standardization? on page 156) • Define the rendering intents. (see Definition of rendering intents on page 160) 	
<p>Printer drivers</p> <p>The Driver Select for Microsoft® Windows® offers color management settings. You can select the required color management settings in the driver or you can indicate to use the printer's default settings. Make sure the color settings do not conflict with the color settings that may be set in another stage of the process.</p>	3

Stages in the process of making a color print	Priority
<p>Webtools Express offers 4 default paths for color settings, based on the file type of the document:</p> <ul style="list-style-type: none"> • [HP-GL/2 - Color management settings] <i>Color management settings for HP-GL, HP-GL/2 and HP-RTL files on page 171</i> • [TIFF and JPEG - Color management settings] <i>Color management settings for TIFF and JPEG files (RGB input) on page 172</i> <i>Color management settings for TIFF and JPEG files (CMYK input) on page 173</i> • [PostScript - Color management settings] <i>Color management settings for PostScript files (RGB input) on page 174</i> <i>Color management settings for PostScript and PDF files (CMYK input) on page 175</i> • [PDF - Color management settings] <i>Color management settings for PDF files (RGB input) on page 176</i> <i>Color management settings for PDF files (CMYK input) on page 177</i> <i>Color management settings for PDF files (Gray input) on page 178</i> <p>These settings are applied when the controller cannot recognize or detect any color settings for the file to be printed.</p>	4



NOTE

It is advisable to align the color management settings that have been made in the different stages before you start the print job. The color space of the document and the settings for the print have to match. This means that if you have set the color settings in more than 1 stage of the process described above, you must check if the color settings do not counteract with each other.

Color management settings for HP-GL, HP-GL/2 and HP-RTL files

The default settings are emphasized.

Input profile	Standardization	[Color feel]	Rendering intent
		[CAD colors]	
RGB	<ul style="list-style-type: none"> • [sRGB] • [Adobe RGB] 	[Graphics colors]	<ul style="list-style-type: none"> • [Perceptual (photo)] • [Saturation (business graphics)] • [Absolute colorimetric] • [Relative colorimetric]
		[None, managed by application]	

Color management settings for TIFF and JPEG files (RGB input)

The default settings are emphasized.

Input profile	Standardization	[Color feel]	Rendering intent
		[CAD colors]	
RGB	<ul style="list-style-type: none">• [sRGB]• [Adobe RGB]	[Graphics colors]	<ul style="list-style-type: none">• [Perceptual (photo)]• [Saturation (business graphics)]• [Absolute colorimetric]• [Relative colorimetric]
		[None, managed by application]	

Color management settings for TIFF and JPEG files (CMYK input)

The default settings are emphasized.

Input profile	Standardization	[Color feel]	Rendering intent
		[CAD colors]	
CMYK	<ul style="list-style-type: none"> • [Euroscale coated] • [Euroscale uncoated] • [US Web coated (SWOP)] • [US Web uncoated] • [ISO Coated v2 300% (ECI)] • [ISO Coated v2 (ECI)] • [PSO Uncoated ISO12647 (ECI)] • [Uncoated FOGRA29] • [GRACoL2006 Coated1v2] • [SWOP2006 Coated3v2] • [SWOP2006 Coated5v2] 	[Graphics colors]	<ul style="list-style-type: none"> • [Perceptual (photo)] • [Saturation (business graphics)] • [Absolute colorimetric] • [Relative colorimetric]
		[None, managed by application]	

Color management settings for PostScript files (RGB input)

The default settings are emphasized.

Input profile	Standardization	[Color feel]	Rendering intent
		[CAD colors]	
RGB	<ul style="list-style-type: none">• [sRGB]• [Adobe RGB]	[Graphics colors]	<ul style="list-style-type: none">• [Perceptual (photo)]• [Saturation (business graphics)]• [Absolute colorimetric]• [Relative colorimetric]
		[None, managed by application]	

Color management settings for PostScript and PDF files (CMYK input)

The default settings are emphasized.

Input profile	Standardization	[Color feel]	Rendering intent
		[CAD colors]	
CMYK	<ul style="list-style-type: none"> • [Euroscale coated] • [Euroscale uncoated] • [US Web coated (SWOP)] • [US Web uncoated] • [ISO Coated v2 300% (ECI)] • [ISO Coated v2 (ECI)] • [PSO Uncoated ISO12647 (ECI)] • [Uncoated FOGRA29] • [GRACoL2006 Coated1v2] • [SWOP2006 Coated3v2] • [SWOP2006 Coated5v2] 	[Graphics colors]	<ul style="list-style-type: none"> • [Perceptual (photo)] • [Saturation (business graphics)] • [Absolute colorimetric] • [Relative colorimetric]
		[None, managed by application]	

Color management settings for PDF files (RGB input)

The default settings are emphasized.

Input profile	Standardization	[Color feel]	Rendering intent
		[CAD colors]	
RGB	<ul style="list-style-type: none">• [sRGB]• [Adobe RGB]	[Graphics colors]	<ul style="list-style-type: none">• [Perceptual (photo)]• [Saturation (business graphics)]• [Absolute colorimetric]• [Relative colorimetric]
		[None, managed by application]	

Color management settings for PDF files (CMYK input)

The default settings are emphasized.

Input profile	Standardization	[Color feel]	Rendering intent
		[CAD colors]	
CMYK	<ul style="list-style-type: none"> • [Euroscale coated] • [Euroscale uncoated] • [US Web coated (SWOP)] • [US Web uncoated] • [ISO Coated v2 300% (ECI)] • [ISO Coated v2 (ECI)] • [PSO Uncoated ISO12647 (ECI)] • [Uncoated FOGRA29] • [GRACoL2006 Coated1v2] • [SWOP2006 Coated3v2] • [SWOP2006 Coated5v2] 	[Graphics colors]	<ul style="list-style-type: none"> • [Perceptual (photo)] • [Saturation (business graphics)] • [Absolute colorimetric] • [Relative colorimetric]
		[None, managed by application]	

Color management settings for PDF files (Gray input)

The default settings are emphasized.

Input profile	Standardization	[Color feel]	Rendering intent
		[CAD colors]	
Grey	<ul style="list-style-type: none"> • [None (no profile used)] • [sGray] • [Adobe Gray 20%] 	[Graphics colors]	<ul style="list-style-type: none"> • [Perceptual (photo)] • [Saturation (business graphics)] • [Absolute colorimetric] • [Relative colorimetric] <p> NOTE Rendering intent is only valid for standardization [sGray] and [Adobe Gray 20%].</p>
		[None, managed by application]	

Manage media

What is a media profile?

Definition

A media profile is also called an Media Profile (OMP file). The media profile contains a number of preset values that give the best print result per media type for your system. By default the system already has a number of media profiles available after installation, but due to changes in the production methods for media, the profiles can change over time. Contact your local representative where you can download new profiles.

When a new media type becomes available that you want your ColorWave 3600 to support, you can install the corresponding Media Profile.

Attributes

For each media type the media profile optimizes a number of settings.

- Mixing of colors (system setting, cannot be modified).
- Settings for optimal paper handling and runability.

Configure the media profiles

Introduction

In WebTools Express you can configure the media profiles on the printer.

Procedure

1. Select the [Media] - [Media types] tab to get an overview of all the media profiles that are available on your ColorWave 3600 printing system.
2. Click the media type, to check the media information.
3. Click the check box of a media type and click the [Enable] button to make the media profile available on the user panel and in the print job submission applications. If you [Disable] a media profile it will no longer be available on the user panel and in the print job submission applications.
4. Click [Install] if you must install a new media profile.



NOTE

You must download the new media profile before you can install it to the ColorWave 3600 embedded controller. Contact your local representative for new media profiles.

5. Click [Delete] to remove a media profile that is no longer needed.



NOTE

This action cannot be undone.

Install a media profile

When to do

When you have downloaded a new or updated media profile, you need to install this media profile to the ColorWave 3600 embedded controller.

Procedure

1. Select the [Media] - [Media types] tab.
2. If you want to update a media profile, click the check box of the media profile you want to update.
3. Click the [Install] button.
4. Click Browse to navigate to the correct file on your workstation.
5. Select the media profile and click "Open".
6. Click the check box of the new or updated media profile and click the [Enable] button to make the media profile available on the user panel.

Result

A warning message appears to inform you of the consequences for the already submitted jobs. The file is stored on the ColorWave 3600 embedded controller. The new file is visible in the media profile list on the [Media types] tab.



NOTE

If an older version of the file was active on the controller, this file will be overwritten by the new file.

Create a custom media size

Introduction

When you want to use custom media with a different roll width than the standard roll sizes, you can create a custom media size on the system in WebTools Express. The system uses this custom media size to automatically detect the roll width when you load your custom media roll.

Procedure

1. Open the [Media] - [Media sizes] tab.
2. Click on [Create a size].
3. Enter a name recognizable for the user. This name appears on the user panel. WebTools Express
4. Enter the desired media size properties.
5. Click [Ok] to confirm, or [Cancel] to reject your entries.

Configure the media sizes

Introduction

You can load various media sizes on the printer. In WebTools Express you can indicate the media sizes to make them recognizable for the printer.

You can also create custom media sizes.

Procedure

1. Open the [Media] - [Media sizes] tab.
2. Under [Supported media sizes] a list with the supported media sizes is displayed.
3. You can enable or disable media sizes to tune the system to your environment.



NOTE

You cannot disable media sizes that are currently loaded on the printer.

Configure mobile printing and scanning

Publisher Express

Introduction

Publisher Express provides the following functionalities:

- Submit a print-ready file to the printer from a mobile device.
- Save a scanned file from the printer on a mobile device.
- Delete a scanned file on the printer.

Illustration

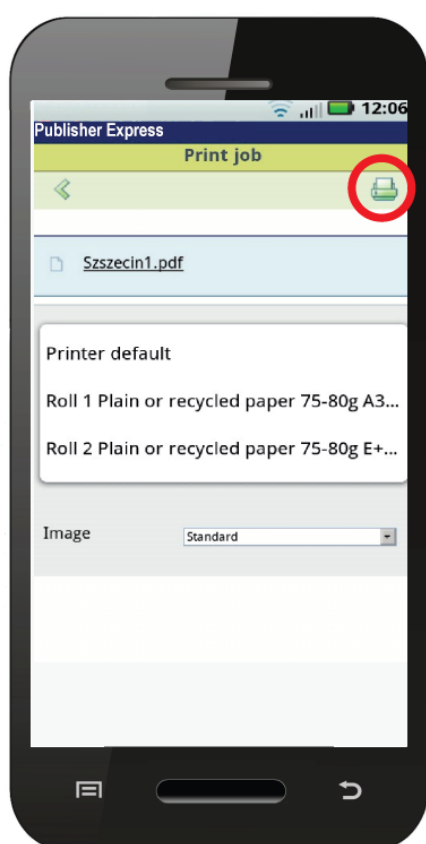

Requirements

Publisher Express can be accessed via the browser on your mobile device.

The following are required in order for this to work:

- A Wi-Fi infrastructure connected to the printer's network.
- A compatible mobile device on which you can access and browse the file system.
- A compatible mobile operating system.
- A compatible mobile web browser.

Optionally:

- You need a mobile file explorer application to print a stored file.

- A mobile application to scan QR Code.

How to use the functionality

When you want to use Publisher Express:

- The system administrator configures the network and Wi-Fi infrastructure
- The System Administrator enters the configuration information on the printer controller interface.

With this information you can generate and print the QR card.

The QR card contains the QR code, and it contains information on how to connect to the Publisher Express.

- The user activates Wi-Fi on the mobile device, and connects to the network. The user opens Publisher Express on the device's web browser.
- With Publisher Express the user can print a file from the mobile device, and the user is able to save a scanned document.

Get the latest information on infrastructure and mobile device compatibility

Refer to the PlotWave-ColorWave Systems Connectivity manual on the <http://downloads.cpp.canon> product page to get information on the connection requirements, or visit <http://www.canon.com/support/> to find more information on mobile connection.

Configure WebTools Express settings for a mobile connection

Introduction

If you want to give users easy access to Publisher Express, the settings must first be configured. With the information you can develop a QR card to create easy access.



NOTE

- For this procedure, you need to log in as Key Operator or Power User.
- Make sure you configure your Wi-Fi network and connect the printer to the network.

Procedure

1. Open the [Configuration] - [Connectivity] tab.
2. Click [Edit] in the right hand corner of the [Mobile] section.
3. Enter the settings. This information will also be printed on the QR card:



NOTE

Enter information according to your IT policy. Contact your system administrator for more information.

Mobile section in WebTools Express

Setting	Action
[Wi-Fi name on QRC sheet]	Enter the name of your Wi-Fi network. The name will be displayed on the QR card.
[Wi-Fi key on QRC sheet]	If required, enter the password for your Wi-Fi network. The key will be displayed on the QR card.

4. Click [Ok] to confirm your settings.



NOTE

When the printer is in a Windows domain network, enter the domain name in WebTools Express:

- Open the [Configuration] - [Connectivity] tab
- Go to the [Network adapter] section. Enter the domain name in the field [Primary DNS suffix].

Generate the Quick Response Card

Introduction

When you want users to easily access the printer from their mobile devices, you can generate the QR (Quick Response) card. The QR card contains all the information to establish a connection between the mobile device and the printer. The card contains all your settings and a uniquely generated QR code. The URL of your printer is displayed, so you can also access Publisher Express on your mobile device via the web browser .

Print the QR card on individual cards or on a poster to provide easy access to the printer.

Before you begin

You need to edit the settings for the connectivity information in WebTools Express first. Only a System Administrator or Power User can edit the information.



NOTE

The illustration below is an example, you cannot print and use this QR card for your personal printer. The printer generates a unique QR card with your own personal QR code, based on your settings.

Illustration

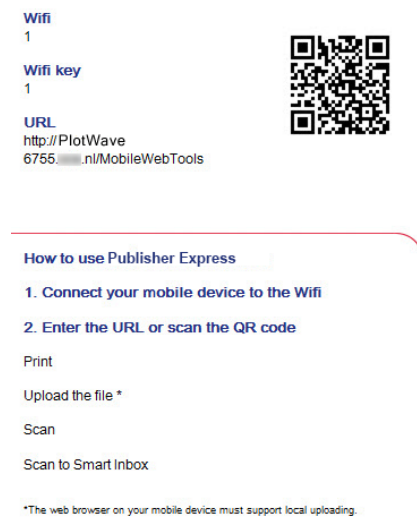

[1] Example of a QR card

Procedure

1. Open the [Support] - [About] tab.
2. Click on [Quick Response Card] in the [Downloads] section.
A new window opens. The QR card is automatically generated and displayed in the window.
3. Print the QR card.

Connect your mobile device to Publisher Express

Before you connect:

- Make sure the system is configured.
- Make sure you generate the QR card.
- Make sure you activate the Wi-Fi connection on your mobile device.



NOTE

- For iOS mobile devices, you can also enter the IP address of the printer in the iCab Mobile browser to get access to the more extended WebTools Express.
- Find the latest compatibility information on the Canon website under the Support tab.
- If the connection fails and cannot be established on your mobile device, contact the system administrator.

Connect to Publisher Express

You can connect to Publisher Express in three ways. Follow the steps to get connected.

Connect with:	Steps
The QR code	<ul style="list-style-type: none"> • Open the QR Code scan application on your mobile device. • Scan the QR code displayed on the QR card. Publisher Express opens in the web browser of your mobile device. • When requested, enter the password on the QR card in order to connect.
The URL	<ul style="list-style-type: none"> • Open the web browser on your mobile device. • Enter the printer's URL, displayed on the QR card. For example: 'http://hostname(.com)/v2/MobileWebTools'. • When requested, enter the password on the QR card in order to connect.
The IP address	<ul style="list-style-type: none"> • Open the web browser on your mobile device. • Enter the printer's IP address. Get the IP address from your system administrator. • When requested, enter the password on the QR card in order to connect.
	<p>Publisher Express opens in the web browser of your mobile device.</p> <p>You can now use it to print from your mobile device or save scanned files on your mobile device.</p>

Chapter 4

Use the printing system

How to feed an original

Introduction

When you want to copy or scan, it is important to correctly feed the original in the printer.



IMPORTANT

- The scanner can not scan an original that is thicker than 0.8 mm or rigid originals.
- Do not retrieve the original from the printer when it is already fed into the scanner. To release the original press the stop button on the user panel and tap [Release the original] under the Smart Access.

Procedure

1. Feed the original face up and centered on the original feeding table.

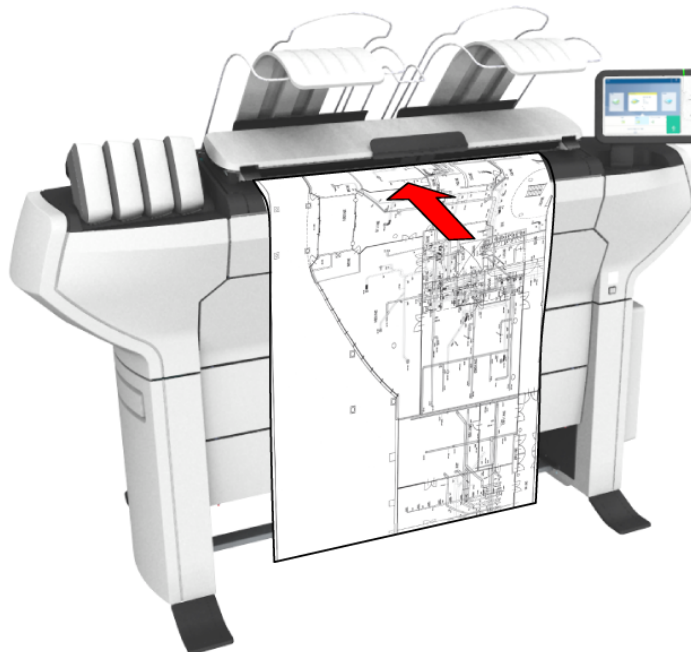

2. The scanner takes the original.
The width of the original is automatically detected and displayed in the Smart Access. The live scan view displays the scanning process.

Result

Depending on the selected [Original release mode] in WebTools Express, the scanner holds or releases the original after the scan procedure. Tap [Release the original] under the Smart Access to let the scanner release the document.

When the original is released, you can feed the next original.

How to auto-feed an original

Introduction

When you activate the auto-feed functionality, you do not need to use the green button every time you scan a document. This way you improve your productivity. The scanner is activated automatically and releases the original after the scan procedure.



NOTE

- The auto-feed functionality is disabled when you select the print tile or when the user panel reverts to the home screen after the specified time-out period.
- You can change the settings of your copy or scan job before you feed the originals.

Procedure

1. Feed the first original face up and centered on the original feeding table.
2. The scanner takes the original.
3. Tap the green button twice. The green button displays the message [Automatic].
4. Tap the green button to start the scan job.
5. When the user panel displays the message [Insert original], you can insert the next original.
6. When you want to de-activate the auto-feed functionality, tap the green button. [Automatic] disappears from the green button.

How to cut the media in roll-to-roll mode

Introduction

When the system is in roll-to-roll mode you can cut the media after a job is finished.

Procedure

1. Tap on the dynamic bar of the user panel.
The queue opens and the Cut icon is visible in the dynamic bar.

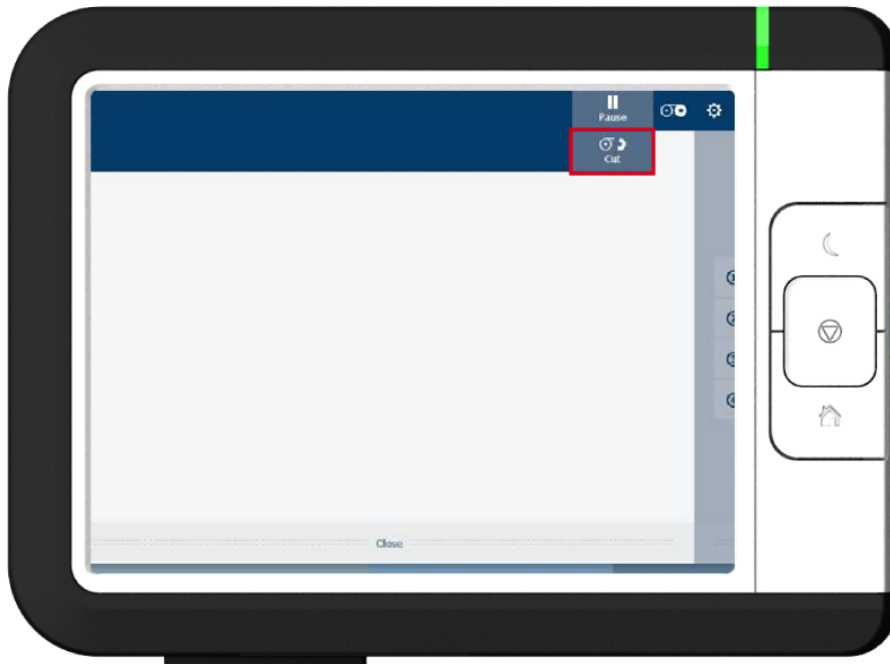

2. Tap on the Cut icon in the dynamic bar to cut the media automatically.

Print Jobs - Job submission tools

Use Publisher Express to send a print job

Introduction

Publisher Express is a job submitter that is integrated in WebTools Express.



NOTE

When you use Publisher Express to submit a print job, the maximum job size is 2 gigabyte.

Illustration

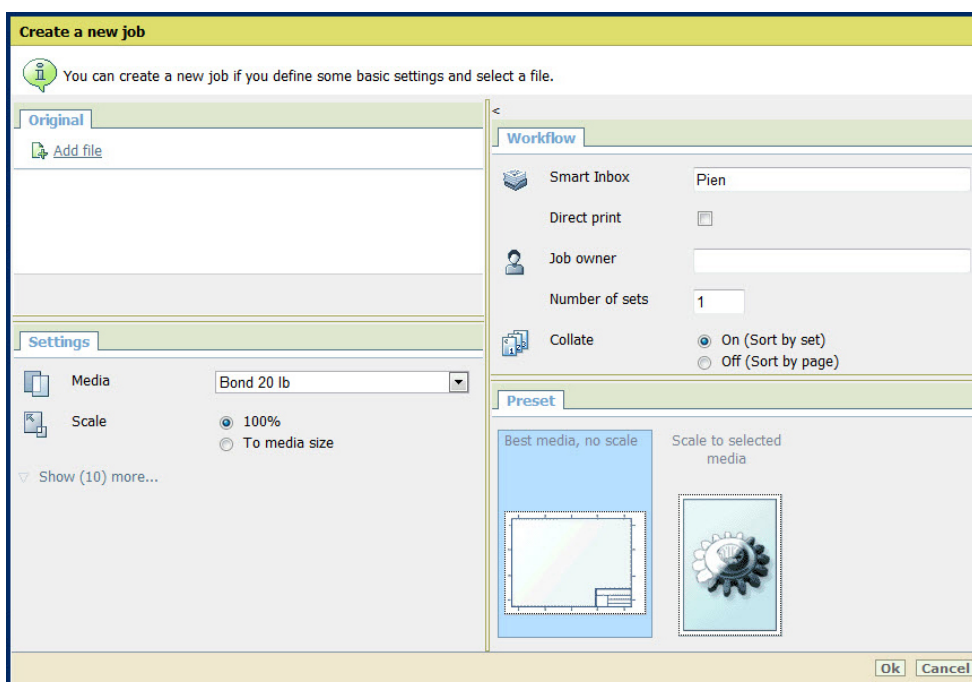

Procedure

Step	Action	Remarks
1	Open the [Jobs] - tab.	This tab displays the following. <ul style="list-style-type: none"> • The Publisher Express section. • An overview of all jobs that are currently available in the Job and Scan Queues. • An overview of all the Smart Inboxes that currently contain one or more jobs.
2	Click on [Create new job] in the Publisher Express section.	A separate window opens. ▶

Step	Action	Remarks
3	<p>Click on [Add file] and use the Browse... button to select the file you want to print. Repeat this action to add more files to the job.</p>	<p>You can only print documents with the following data formats. When you use other formats, the file cannot be sent to the printer.</p> <ul style="list-style-type: none"> • HP-GL - .hp, .hpg, .hpgl • HP-GL/2 - .hp2 • HP RTL - .rtl • CALS - .cls, .cal • NIRS - .nir, .nif • CalComp - .cc, .906, .907, .951, .crf, .pci • Edmics (C4) - .c4 • TIFF - .tif • PostScript 3 - .ps (licensed) • PDF - .pdf (licensed) • JPEG - .jpg, .jpeg
4	<p>Select the [Preset] and change the [Settings] if necessary.</p>	<p>Job settings that you change in Publisher Express always overrule the default settings defined in WebTools Express.</p>
5	<p>In the [Workflow] section enter the name of the Smart Inbox you want to print to and click [Ok] to send the print job to the Smart Inbox.</p>	<p>You can easily create a new Smart Inbox when you enter a new Smart Inbox name.</p>

Use the Smart Inbox to send a print job

Introduction

If you have already added a job to the Smart Inbox in WebTools Express, you can print this job via the Smart Inbox.



NOTE

For more information on how to create a Smart Inbox, see [Create and open a Smart Inbox on page 78](#).

Procedure

1. Select the [Jobs] tab in WebTools Express.
2. Click on "Open Smart Inbox".
3. Click on the white field and select the correct Smart Inbox.
4. Select the job and click [Print]. The job is copied into the queue.

Use Publisher Select 3 to send a print job

Introduction

Publisher Select 3 is a job submission application that allows you to create, preview, print, and manage jobs for the ColorWave 3600.



NOTE

You can download the Publisher Select 3 software on "<http://downloads.cpp.canon>" under the product page. Here you can also download the operation guide for more information.

Publisher Select 3

Use Publisher Select 3 to:

- Connect to the printer.
- Set up the application settings to your preferences.
- Check the media and ink available in the printer.
- Create a job.
- Submit your job to the printer.

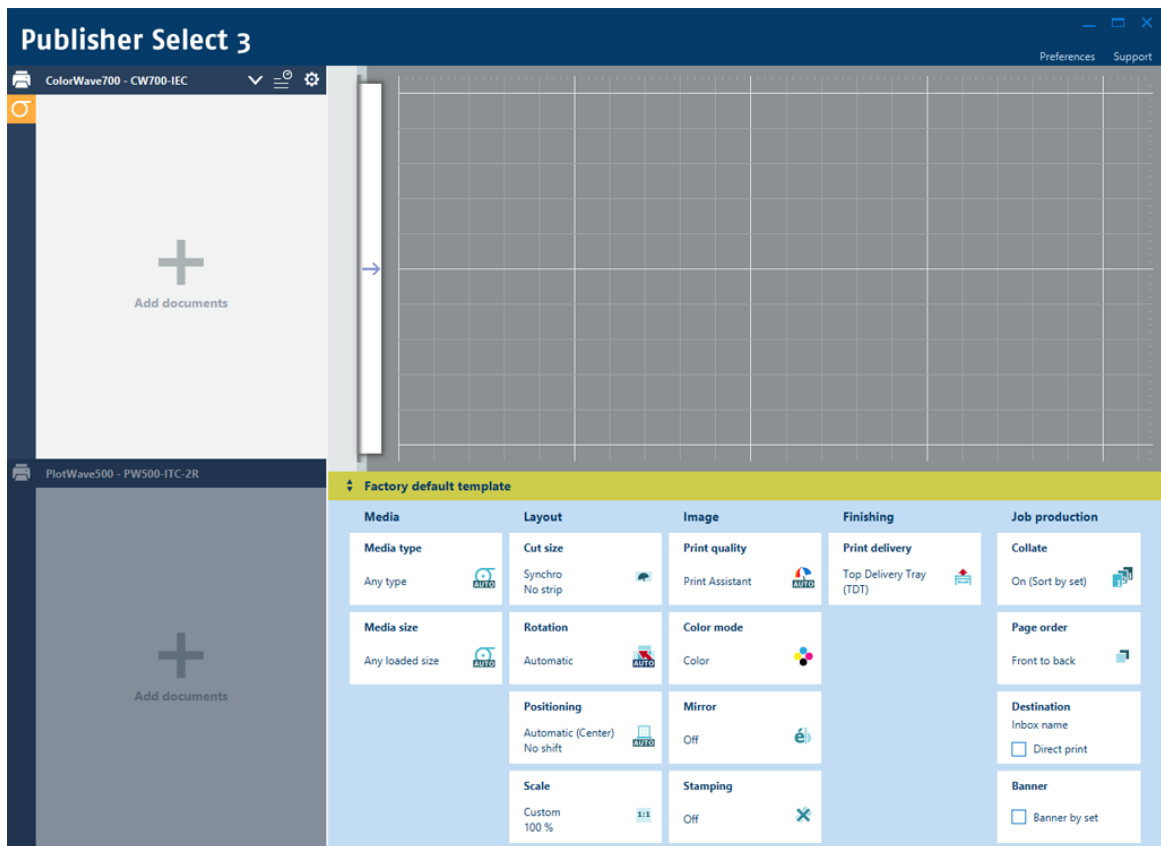

Use Publisher Select 3 to send a print job

1. Start Publisher Select 3 and connect it to the printer.
The home screen opens.
2. In the left part of the screen, check the printer status for the available ink and media.
3. Select a template or create a custom template and select it.
4. Add documents to the job.

5. Select documents of the job to check or adjust the print settings.
6. Check the print preview.
7. Click on the green print button, to print the job.
8. Track and manage a submitted job in the submitted jobs list.

Use Driver Select for Microsoft® Windows® to send a print job

Introduction

Driver Select for Microsoft® Windows® is a mixed raster-vector HP-GL/2 printer driver that allows you to create, preview, print, and manage jobs for your printer.



NOTE

For more information on Driver Select for Microsoft® Windows®, go to "<http://downloads.cpp.canon>" and select your product.

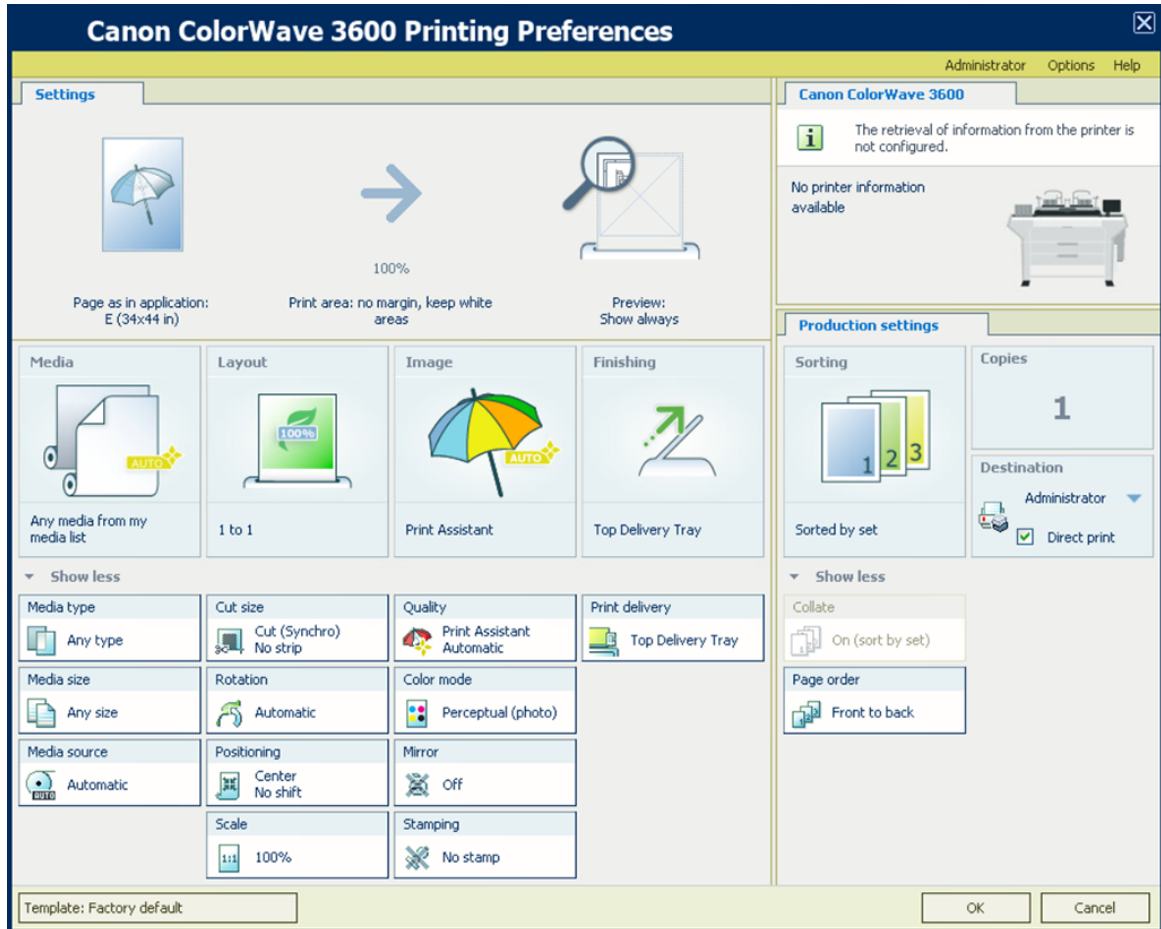

Procedure

1. Open the file that you want to print in the source application. AutoCAD® or any other Windows application
2. From the [File] menu of the application, click [Print].
3. Select the product name of your printer in the [Printer] area of the [Print] dialog box.
4. Click [Properties].

You can define the default print job settings in WebTools Express.

5. In the [Options] menu in the upper right hand corner of the screen choose [Advanced options]. Make sure a checkmark is placed in the [Océ Job Ticket enabled] box of the [Troubleshooting] section to overrule the default values for the job settings.

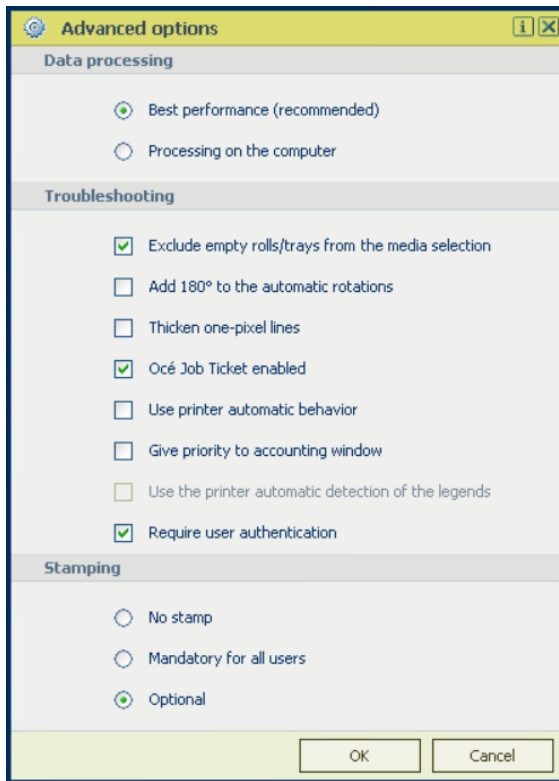

6. Check all tiles in the printer driver and change the settings, if necessary.
7. Click [OK] to send the print job to the [Smart Inbox] or the print queue.

Use the Driver Express for Adobe® Postscript® 3™ to send a print job

Introduction

Canon provides the Driver Express for Adobe® Postscript® 3™ that allows you to send print jobs to your printer.

You need a license to be able to print PostScript files on the printer.

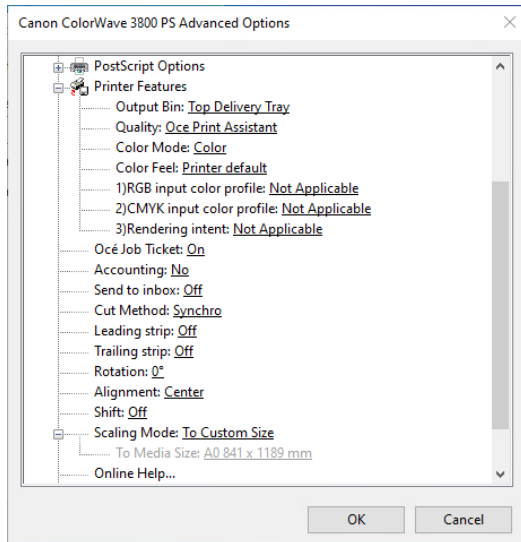

Procedure

1. Open the file that you want to print in the source application.
2. From the [File] menu of the application, click [Print].
3. Select the product name of your printer in the [Printer] area of the [Print] dialog box.
4. Click [Properties] and [Advanced].
When you select Properties you can define the settings for your print job.
5. Activate the Job Ticket to overrule the default values for the job settings.
6. Check and change the Printer Features settings if necessary.
7. Click [OK] to send the print job to the Smart Inbox or the print queue.

Use Publisher Mobile to send a print job

Introduction

Publisher Mobile is an application that enables you to easily plot from an system via your iPhone, iPad, or Android device.

All TCS, TDS, ColorWave and PlotWave systems are supported. A user can plot all PDF*, PLT (HPGL1/2), TIFF, JPEG and DWF* files.



NOTE

* Supported file types can vary depending on your system and active licenses.

Before you begin

Download Publisher Mobile from the Play Store for Android devices or the App Store for iOS devices.

Illustration

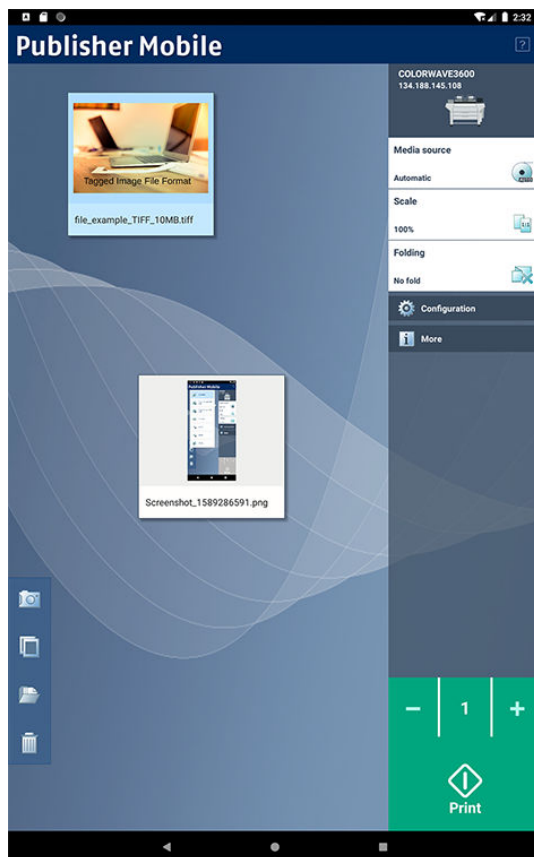

Procedure

Add a printer to Publisher Mobile

Step	Action	Remarks
1	Open Publisher Mobile on your mobile device.	

Step	Action	Remarks
2	Tap the printer button.	Publisher Mobile detects the compatible printers that are available in your network.
3	The detected printer, indicated with a "Connection" icon, is added to your printer list.	If your printer is not detected, you can add it manually. Tap the "Add" printer button.
4	From the printer list, select your printer.	
5	Tap the "Configure" icon next to the printer name.	The printer configuration window opens.
6	Enter the IP address or hostname of the printer	
7	Add the settings for the printer.	<ul style="list-style-type: none"> • Enter a name • Check or define the printer model • Define the number of rolls • Indicate if there is a folding device
8	Save the settings. Your printer is added.	 NOTE You can also open WebTools Express. Tap the hyperlink in the configuration window. This is useful to: - know the printer status - enter accounting information -see your Smart Inbox -see if there is an error.

Send a print job from Publisher Mobile

Step	Action	Remarks
1	Open the file you want to print in Publisher Mobile.	
2	Select your printer.	
3	Define the print settings you need.	Main settings you can select: <ul style="list-style-type: none"> • Media source • Scale • Folding
4	Indicate the number of copies.	
5	Tap the green button	Your job is sent to the printer.

Print from your mobile device

Introduction

When you have access to Publisher Express you can print a file from your mobile device on the printer .



NOTE

- You can navigate in a file repository on your mobile device. If needed, install a file explorer application. For more details refer to the Canon website.
- Make sure you have a working connection.
- When the system requires accounting information, your print job is sent to the Smart Inbox named [Mobile] in WebTools Express. It is not printed. Connect to WebTools Express from a workstation. Enter the accounting information to print the job.

Illustration

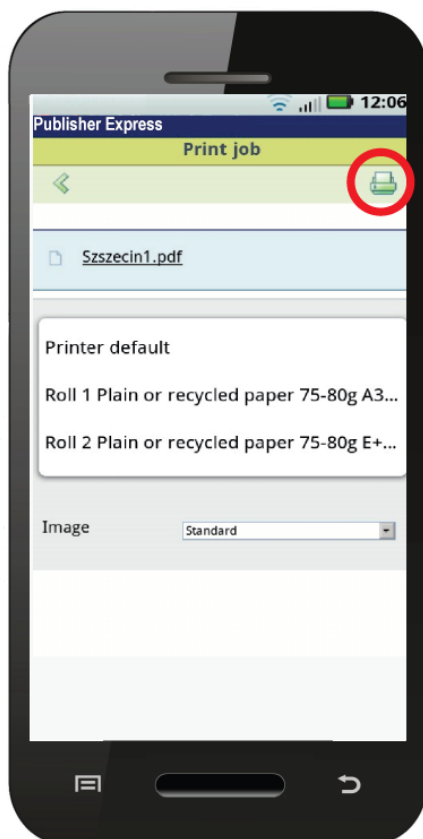

Procedure

1. Go to the [Print] section and select [New job].
The [Print job] window opens.
2. Click on [Select a file].
3. Browse to the file you want to print and click Open.
4. Define the settings for your print job and click Ok.
5. After defining your settings, click on the printer icon in the upper right-hand corner. The job is sent to the printer.

Result

Your document is printed. Your print job appears on the user panel and in the job queue of WebTools Express, while it is being printed.

Use FTP to send a print job

Introduction

The printer supports printing through FTP.

When you send your print job through FTP the default WebTools Express settings are leading.



NOTE

- You must enable printing through FTP in WebTools Express.
- For more information on how to create an external location via FTP on the user panel, see [Create an external location on page 121](#).

Before you begin

Find the network settings and IP address of your printer on the user panel.

Tap the system menu thumbnail and select [Network settings] in the list. A wizard opens with the required information.

How to send a print job via FTP

You can print the files through FTP in the following ways.

- Via a command line prompt
- Via an FTP application
- Via Windows File Explorer:
select the folder **ftp://<hostname or IP address> /jobs** in Windows File Explorer.

The printer has a dedicated FTP Jobs folder. You cannot delete or change this folder. It is created at installation and protected. The most convenient way to print files through FTP is to drag and drop the files, or to copy and paste the files into this [Jobs] folder in Windows File Explorer. The documents in the folder are printed on your printer.

Use LPR to send a print job

Introduction

The printer supports printing through LPR.

When you send your print job through LPR and there is no job ticket, the default WebTools Express settings are leading.



NOTE

You must enable printing through LPR in WebTools Express.

How to send a print job via LPR

Type the following line command after the Command prompt: **lpr -S** <hostname or IP address> **-P** <print queue name> <file name>.



NOTE

You can use any name for <print queue name>, for example **jobs**.

Use the cloud to send a print job

Introduction

The cloud can be seen as a virtual network drive you use to send files to, but also to save and share files on.

There are general cloud applications, such as SharePoint or applications via a HTTP URL, but companies can also use their own private and internal clouds.

Before you begin

Create an external location via [WebDAV] in WebTools Express to enable your cloud connection with the printer. For more information, see [Create an external location on page 121](#) .

Procedure

1. Open your cloud application, on your mobile device.
2. Depending on the application you use:
 - add and save the file you want to print or...
 - send the file to the printer.

Use the home folder to send a print job

Introduction

When you have enabled user authentication in WebTools Express you can use the home folder to print from or to scan to.



NOTE

The home folder is a personal and secure external location, you can only use when it is configured by your IT department as part of your infrastructure.

Before you begin

Enable [User authentication] with [User name and password] configured and enable the home folder as a location first. For more information, see [Enable and edit the Home folder on page 119](#).

Procedure

1. Log in on Publisher Express or any of the other job submitters, using your credentials [User name and password].
2. Create a job with files from your home folder and submit it to the printer.
3. Log in on the printer user panel using your credentials [User name and password]. You only see your personal locations.
4. Select the job and click on the green button.

Troubleshoot print job submission

Introduction

Check the issues and solutions to troubleshoot print job submission.

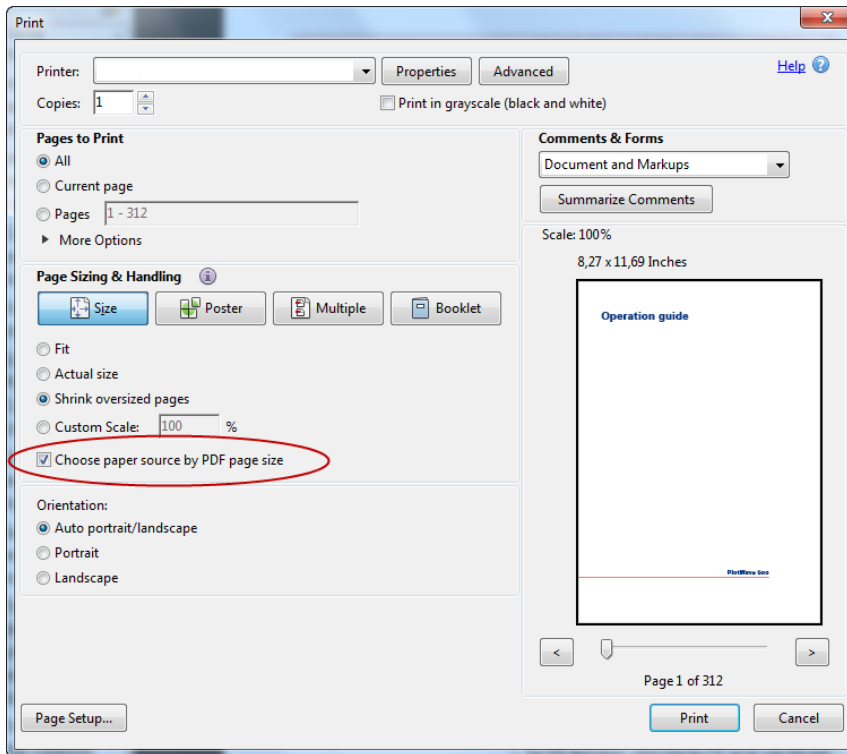

Issue	Solution
Unable to print a PDF file using Adobe Acrobat reader.	When you submit the print job (File - Print), make sure you check the box 'Choose paper source by PDF page size' in the print dialog.

Print Jobs

Do a default print job

Introduction

When you want to print a job and you do not make any settings, the default presets are used. You only use the Smart Access to start your job.

You can see the presets that are used in the job settings section of your job.

Before you begin

Make sure you submit a job via one of the job submitter applications:

Publisher Express	Use Publisher Express to send a print job on page 193
Publisher Select	Use Publisher Select 3 to send a print job on page 196
Wide format Printer Driver for Microsoft® Windows®	Use Driver Select for Microsoft® Windows® to send a print job on page 198
Driver Express for Adobe® Postscript® 3™	Use the Driver Express for Adobe® Postscript® 3™ to send a print job on page 200
Publisher Mobile	Use Publisher Mobile to send a print job on page 201
Publisher Express (Mobile version)	Print from your mobile device on page 203

Or submit a job via

LPR	Use LPR to send a print job on page 206
FTP	Use FTP to send a print job on page 205
The cloud (WebDAV)	Use the cloud to send a print job on page 207
The home folder	Use the home folder to send a print job on page 208
PlanWell Collaborate	Use the cloud to send a print job on page 207
USB	Print from a USB key on page 213



NOTE

This following procedure applies when you have not made settings to enable direct print. With direct print, the job will be printed immediately. For more information, see [Direct print on page 212](#).

Procedure

1. After you have submitted a job to the printer, tap the print tile on the user panel to open the list of locations.

2. Select the location of your job. Default, the public Smart Inbox.



- The jobs are listed in a new window.
3. Select your job from the list.
 4. Tap the green button, next to the job settings.

Direct print

Introduction

When you want to do a default print job:

- You can print with direct print.
When you print with direct print, the print job is sent to the queue immediately.
- You can print without direct print.
When you print without direct print you can start the job locally at the printer.



NOTE

- When the [Preferences] - [System defaults] - [Job management] - [Override destination of print jobs] is set to [Yes, send only to Smart Inbox], you cannot print directly and you have to start the print job at the printer. When you want to print with direct print, you must change this setting in WebTools Express.
- For more information on how to submit a print job via Publisher Express see [Use Publisher Express to send a print job on page 193](#).

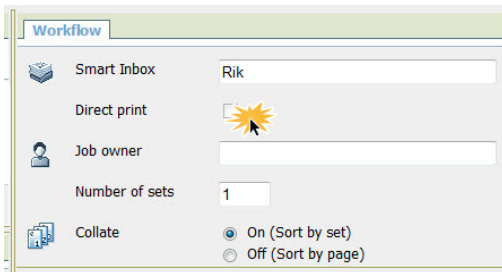

Do a default print job with direct print

Step	Action
1	Send a job to the printer via one of the job submitters and select "direct print" in the job ticket. Usually via Publisher Express in WebTools Express.
2	Go to the printer to collect your print.

Do a default print job without direct print

Step	Action
1	Send a job to the printer and select the preferred Smart Inbox as a location, via one of the job submitters.
2	Go to the printer and open your Smart Inbox, via the Smart Access on the user panel.
3	Select your job in the Smart Inbox.
4	Tap the green button to print your job.

Print from a USB key

Introduction

With a USB key, you can perform print and scan jobs on the printer.

Procedure

1. Insert a USB key into the USB port on the multi-touch user panel.
The print tile is automatically selected on the user panel, and the USB location is active.
2. Tap on the USB location in the print Smart Access.
A window with a list of the folders and files present on your USB key opens. Swipe through the list and find the correct file.

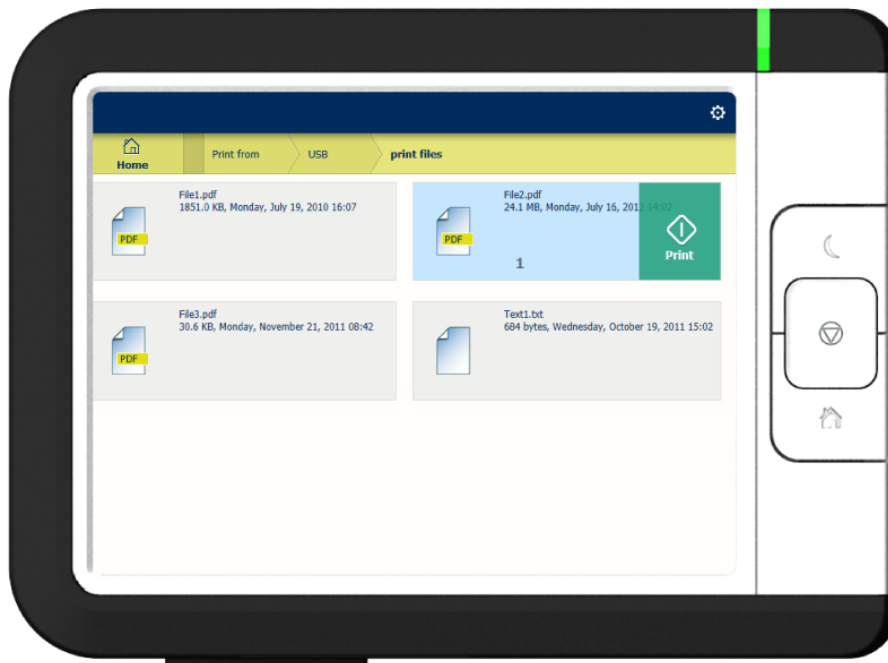

3. Tap the green button to start the job.
When you want to make more settings, you can tap on the job name and job settings. The preset window opens, and you can make additional settings.

Print presets on the user panel

Introduction

The printer uses the default presets for print and copy jobs, when you do not make different settings. The print presets are divided into four categories:

- [Media]
- [Layout]
- [Image]
- [Finishing]

You can change the presets for all of these categories in WebTools Express. For more information on:

The preset concept	<i>What you need to know about presets on page 104</i>
How to change the preset settings	<i>Set the default print preset on page 107</i>

The Image preset for print jobs

Introduction

With the [Image] preset, the quality and the productivity of a print job can be defined. There are five pre-defined presets and a sixth custom preset can be created in WebTools Express.

Image presets

Use the overview, to select the best [Image] preset for your job.

Image preset	Properties
[Print Assistant]	This preset is used by default. For most originals, good quality color prints can be made. The Print Assistant automatically determines the best print quality for your job.
[Fast CAD Color]	Use the preset for color CAD drawings, when productivity is an important factor.
[Normal CAD/Poster]	Use the preset for color CAD drawings and posters, when quality is an important factor.
[Quality poster/Photo]	Use the preset for the full range of photo-like originals with high color accuracy, when quality is an important factor .
[Fast CAD B/W]	Use the preset for black and white CAD drawings, when productivity is an important factor.

Advanced settings for print jobs

Introduction

When you tap the Scan tile on the multi-touch user panel, you can make your own settings.



Apart from the preset tiles, you can select the advanced settings under [Show all settings]. These settings are used for extended print jobs. The following table gives an overview and a short description of the available settings on the printer. You can find a detailed description of each setting in WebTools Express.



Preset category: [Media]

Setting	Settings values	Function
[Media type]	Any type List of media types	The type of media you use.
[Media size]	Any size List of media sizes	The size of media you use.
[Media source]	[Automatic] 'Roll 1 to 4' (description of media type and media size loaded on the specific roll)	Define the media feed to copy or print on. When you select [Auto] the printer automatically selects the media roll. 

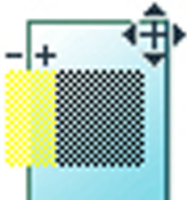
Preset category: [Layout]

Setting	Settings values	Function
[Cut size]	[Cut method]: <ul style="list-style-type: none"> • [Synchro] • [Standard] • [Custom] 	<p>When set to [Synchro], the print is cut dependent of the image size.</p> <p>When set to [Standard], the print is cut to a standard media size.</p> <p>When set to [Custom], you must enter the sizes manually.</p> 
	[Custom cut length]	Cuts the print at the defined length. From 210 to 20,000 mm, or 8.3 to 7874 inches.
	[Add a leading strip]	Adds a blank strip at the beginning of the output. From 0 to 400 mm, or 0 to 16 inches.
	[Add a trailing strip]	Adds a blank strip at the end of the output. From 0 to 400 mm, or 0 to 16 inches.
[Rotation]	[0°] [90°] [180°] [270°] [Short edge first] [Long edge first] [Auto rotate media saving] [Auto rotate media saving with additional 180° rotation]	Rotates the image counterclockwise. Select [Automatic media saving] to use the media in the most efficient way.

Setting	Settings values	Function
[Positioning]	[Alignment]: <ul style="list-style-type: none"> • [Top left] • [Top] • [Top right] • [Left] • [Center] • [Right] • [Bottom left] • [Bottom] • [Bottom right] 	[Aligns the image on the sheet.] 
	[Horizontal shift]	[Shifts the image in the horizontal direction (after alignment to one of the positions given in 'Alignment').] From - 1067 mm to 1067 mm, or - 42 to 42 inches. 
	[Vertical shift]	[Shifts the image in the vertical direction (after alignment to one of positions given in "Alignment").] From - 1219 mm to 1219 mm, or - 48 to 48 inches. 

Setting	Settings values	Function
[Scale]	[1:1]	Scales the image to the original size.
	[To media size]	Scales to the selected media width.  NOTE You can only use this setting, when a specific media roll is selected.
	[To standard size]	Scales the image to fit the media size you select from a list. 
	[Custom]	Scales the image to a custom percentage. 10 - 1000% 

Preset category: [Image]

Setting	Settings values	Function
[Print quality]	<ul style="list-style-type: none"> • [Print Assistant] • [High speed] • [Economy - fast] • [Production] • [Quality] 	Define the print quality of your output. <ul style="list-style-type: none"> • Select [Print Assistant] for an automatic, optimal print quality selection. • In the print quality range from [High speed] to [Quality] the quality increases while the speed decreases. In case the [Color mode] setting is set to [Grayscale] the print quality [Economy - fast] uses color toner to increase the density of grayscale prints.
[Color mode]	[Color] [Grayscale]	Define the default output in color or grayscale. ▶

Setting	Settings values	Function
[Mirror]	[On] [Off]	<p>[When 'On', the image is mirrored along the vertical axis (the media transport direction).] Set to [On] for strongly curled transparent originals that have to be fed upside down in the scanner. Or for (dark) transparent originals that have the information printed on the back.</p> 

Preset category: [Finishing]

Setting	Settings values	Function
[Delivery]	[Top Delivery Tray]	<p>Location on top of the printer that deposits the sheet face-down.</p>  NOTE Not all media types can be delivered to the [Top Delivery Tray].
	[Back output] or [Fold].	<p>Select [Back output] to default deliver your output at the back of the printer. Select the folding device when it is configured, and you want to fold your output.</p>
	[Fold template]	<p>When a folding device is configured, you can select the preferred fold template, to fold with predefined settings.</p>

Copy Jobs

Do a default copy job

Introduction

When you want to copy an original and you do not make any settings, the default presets are used. You only use the Smart Access to submit your job.

You can see the presets that are used in the job settings section of your job.

Procedure

1. Feed the original face up and centered on the original feeding table.
The copy tile with the copy Smart Access is automatically selected on the user panel.



2. Select the number of copies and tap the green button.



NOTE

Tap on [Release the original] under the Smart Access to release your original from the scanner.

Copy presets on the user panel

Introduction

The printer uses the default presets for print and copy jobs, when you do not make different settings. The copy presets are divided into four categories:

- [Media]
- [Layout]
- [Image]
- [Finishing]

You can change the presets for all of these categories in WebTools Express. For more information on:

The preset concept	<i>What you need to know about presets on page 104</i>
How to change the preset settings	<i>Set the default copy preset on page 105</i>

The Image preset for copy jobs

Introduction

With the [Image] preset, the quality and the productivity of a copy job can be defined. There are five pre-defined presets and a sixth custom preset you can create in WebTools Express.

Image presets

Use the [Image] setting to select the default stamp for your output.

Image preset	Properties
[Normal color]	This preset is used by default. For most originals, good quality color copies can be made. The quality settings are balanced between color accuracy, and the enhancement of fine information while background is being suppressed.
[Photo/Poster]	Use the preset for the full range of a photo-like originals with high color accuracy.
[Fast CAD]	Use the preset for color CAD drawings, when productivity is an important factor. Line information is enhanced and background is suppressed. When you have a CAD original with large area fills, choose the [Normal color] preset.
[Normal CAD B/W]	Use the preset for black and white CAD drawings, when quality is an important factor. Line information is enhanced and background is suppressed.
[Fast CAD B/W]	Use the preset for black and white CAD drawings, when productivity is an important factor. Line information is enhanced and background is suppressed. When you have a black and white CAD original with large area fills, choose the [Normal CAD B/W] preset.

Advanced settings for copy jobs

Introduction



When you tap the copy tile on the multi-touch user panel, you can make your own settings.



Apart from the preset tiles, you can select the advanced settings under [Show all settings]. These settings are used for extended copy jobs. The following table gives an overview and a short description of the available settings on the printer. You can find a detailed description of each setting in WebTools Express.



Preset category: [Media]

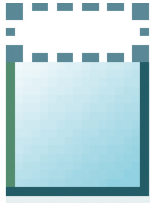
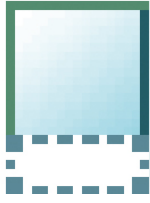
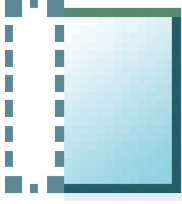

Setting	Settings values	Function
[Media type]	Any type List of media types	The type of media you use.
[Media size]	Any size List of media sizes	The size of media you use.
[Media source]	[Auto] 'Roll 1 to 4' (description of media type and media size loaded on the specific roll)	Define the media feed to copy or print on. When you select [Auto] the printer automatically selects the media roll. 

Preset category:[Layout]

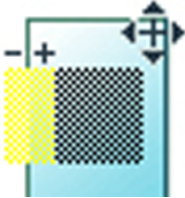
Setting	Settings values	Function
[Cut size]	[Cut method]: <ul style="list-style-type: none"> • [Synchro] • [Standard] • [Custom] 	<p>When set to [Synchro], the print is cut dependent of the image size.</p> <p>When set to [Standard], the print is cut to a standard media size.</p> <p>When set to [Custom], you must enter the sizes manually.</p> 
	[Custom cut length]	<p>Cuts the print at the defined length.</p> <p>From 210 to 20,000 mm, or 8.3 to 7874 inches.</p>
	[Add a leading strip]	<p>Adds a blank strip at the beginning of the output.</p> <p>From 0 to 400 mm, or 0 to 16 inches.</p> 
	[Add a trailing strip]	<p>Adds a blank strip at the end of the output.</p> <p>From 0 to 400 mm, or 0 to 16 inches.</p> 

Setting	Settings values	Function
[Remove strip]	[Top]	<p>[Erase a strip from the beginning of the original.] From 0 to 400 mm, or 0 to 16 inches.</p> 
	[Bottom]	<p>[Erase a strip from the bottom of the original.] From 0 to 400 mm, or 0 to 16 inches.</p> 
	[Left]	<p>[Erase a strip from the left side of the original.] From 0 to 400 mm, or 0 to 16 inches.</p> 
	[Right]	<p>[Erase a strip from the right side of the original.] From 0 to 400 mm, or 0 to 16 inches.</p> 





Setting	Settings values	Function
[Positioning]	[Alignment]: <ul style="list-style-type: none"> • [Top left] • [Top] • [Top right] • [Left] • [Center] • [Right] • [Bottom left] • [Bottom] • [Bottom right] 	[Aligns the image on the media.] 
	[Horizontal shift]	[Shifts the image in the horizontal direction (after alignment to one of the positions given in 'Alignment').] From - 1067 to 1067 mm, or - 42 to 42 inches. 
	[Vertical shift]	[Shifts the image in the vertical direction (after alignment to one of positions given in 'Alignment').] From - 1219 to 1219 mm, or - 48 to 48 inches. 

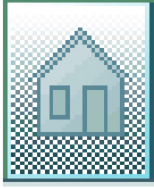

Setting	Settings values	Function
[Scale]	[1:1]	Scales the image to the original size.
	[To media size]	Scales to the selected media width.  NOTE You can only use this setting, when a specific media roll is selected.
	[To standard size]	Scales the image to fit the media size you select from a list. 
	[Custom]	Scales the image to a custom percentage. 10 - 1000% 





Preset category: [Image]

Setting	Settings values	Settings values	Function
[Quality]	[Scan quality]	[Normal] [High]	Define the quality of the scan. <ul style="list-style-type: none"> • Select [High] to scan with a higher resolution. This can prevent a moiré pattern for originals that contain gray or colored areas. • For pure CAD originals [Normal] is mostly sufficient. Select [Normal] when productivity is an important factor.
	[Print quality]	[Automatic] [High speed] [Economy - fast] [Production] [Quality]	Define the print quality of your output. <ul style="list-style-type: none"> • Select [Automatic] for an automatic, optimal print quality selection. • Select the print quality from [High speed] to [Quality], in which the quality increases while the speed decreases. In case the [Color mode] setting is set to [Grayscale] the print quality [Economy - fast] uses color toner to increase the density of greyscale prints.
	[Color mode]	[Color] [Grayscale]	Define the default output in color or greyscale.

Setting	Settings values	Settings values	Function
[Original]	[Original type]	[Folded lines/text] [Lines/text] [Map] [Colored original] [Artwork] [Photo] [Blueprint] [Dark original]	<p>Define the type of original you use. The choice depends on the chosen [Color mode]. For more information on choosing the correct original type, see The original type on page 236.</p> 
	[Background compensation]	[Automatic] [On] [Off]	<p>Reduce the background noise of the image.</p> <ul style="list-style-type: none"> • Default is [Automatic]. Dependent of the chosen [Original type], background compensation is automatically applied or not. • Override [Automatic] by selecting [On] or [Off]. <p>The applied background compensation method depends on the chosen original type.</p> 

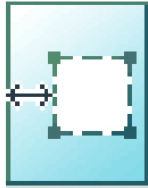
Setting	Settings values	Settings values	Function
[Original]	[Original width]	[Auto]	<p>The width of the original is automatically detected by the scanner.</p> 
		[Standard]	<p>Select the width of the original as a standard size.</p>  <p> NOTE Depends on the media type and size you have configured in WebTools Express</p>
		[Custom]	<p>The width of the original is a custom size. You can enter a size within the range of 210 to 914 mm, or 8.5 to 36 inches.</p> 

Setting	Settings values	Settings values	Function
[Image]	[Color highlighting]	[On] [Off]	<p>Set to [On]:</p> <ul style="list-style-type: none"> to make notes made with marker pens more visible. to emphasize colors, of CAD drawings with colored information and a solely greyscale (black) background information. <p> NOTE</p> <ul style="list-style-type: none"> When the [Color mode] is set to [Color], color highlighting will make the colors more saturated. When the [Color mode] is set to [Grayscale], colors will be copied darker than the greyscale information on the original. The setting is disabled for the original types, [Photo], [Artwork], [Blueprint].
	[Lighter/Darker]	Value from -5 to 5	<p>Define the lightness and the contrast of a copy. Increase the value for lighter prints, and decrease for darker prints.</p> <p>When you make a copy darker, the information becomes darker while the background is less affected. When you make a copy lighter, weak information is not clipped to white.</p>
	[Mirror]	[On] [Off]	<p>[When "On", the image is mirrored along the vertical axis (the media transport direction).]</p> <p>Set to [On] for strongly curled transparent originals that have to be fed upside down in the scanner. Or for (dark) transparent originals that have the information printed on the back.</p> <p></p>

Setting	Settings values	Settings values	Function
[Area to erase]	[Area to erase: X origin]	From 0 to 914 mm, or 0 to 36 inches	[The origin of the area to erase on the horizontal axis, starting from the left.] 
	[Area to erase: Y origin]	From 0 to 6000 mm, or 0 to 250 inches.	[The origin of the area to erase on the vertical axis, starting from the top.] 
	[Area to erase: width]	From 0 to 914 mm, or 0 to 36 inches.	[The width of the area to erase.] 
	[Area to erase: length]	From 0 to 6000 mm, or 0 to 250 inches.	[The length of the area to erase.] 

Preset category: [Finishing]

Setting	Settings values	Function
[Delivery]	[Top Delivery Tray]	Location on top of the printer that deposits the sheet face-down.  NOTE Not all media types can be delivered to the [Top Delivery Tray].
	[Back output] or [Fold].	Select the [Back output] to deliver your output face-up, at the back of the printer. Select the folding device when it is configured, and you want to fold your output.
	[Fold template]	When a folding device is configured, you can select the preferred fold template, to fold with predefined settings.

Recommended settings for copy jobs

Introduction

Use the advised settings to optimize the output of your copy job.

Dependent of a color or grayscale copy job, select the corresponding settings.

Workflow

1. Start by selecting the best image preset for your job. Use column two in the table below, or for more information see [The Image preset for copy jobs on page 223](#).
2. When you want to further optimize the settings, you can select the advanced settings, under [Show all settings] on the user panel. When you want to influence the imaging process and thus optimize the output quality, you can select the corresponding [Original type] for your job. Use column three in the table below, or for more information see [Advanced settings for copy jobs on page 224](#) and [The original type on page 236](#).

Advised settings for color copy

Original document	[Image] preset	Optimize under [Show all settings]
(Folded) CAD drawing	[Fast CAD] with large area fills: [Normal color]	<ul style="list-style-type: none"> • For folded originals set the original type to [Folded lines/text] • When you want to emphasize colors, set [Color highlighting] to [On].
(Folded) CAD drawing with marks from marker pens	[Fast CAD]. with large area fills: [Normal color]	<ul style="list-style-type: none"> • For folded originals set the original type to [Folded lines/text] • When you want to emphasize colors, set [Color highlighting] to [On].
Map, GIS, business graphics, etc.	[Normal color]	
Architectural impressions, artwork etc.	[Normal color]	Set original type to [Artwork]
Photos, posters, and high definition color prints	[Photo/Poster]	
Medium quality color prints	[Normal color]	

Advised settings for grayscale copy

Original document	Preset [Image]	Optimize under [Show all settings]
(Folded) CAD drawing	[Fast CAD B/W] with large area fills: [Normal CAD B/W]	For folded originals set the original type to [Folded lines/text]

Original document	Preset [Image]	Optimize under [Show all settings]
(Folded) CAD drawing with marks from marker pens	[Fast CAD B/W] with large area fills: [Normal CAD B/W]	<ul style="list-style-type: none"> • Set original type to [Colored original] • When you want to emphasize colors, set [Color highlighting] to [On].
(Folded) Color CAD drawings, maps, business graphics, etc.	[Fast CAD B/W] with large area fills: [Normal CAD B/W]	<ul style="list-style-type: none"> • Set original type to [Colored original] • When you want to emphasize colors, set [Color highlighting] to [On].
CAD originals with a non uniform background	[Fast CAD B/W]	Set original type to [Dark original]
Diazo copies / "Chinese blueprints"	[Fast CAD B/W]	Set original type to [Dark original]
Dark (transparent) originals	[Fast CAD B/W]	Set original type to [Dark original]
Photos and high-definition color prints	[Photo/Poster]	Set [Color mode] to [Grayscale]
Blueprints with white lines on a blue background	[Fast CAD B/W]	Set original type to [Blueprint]

The original type

Introduction

When you change the [Original type] setting under [Show all settings] - [Original] on the user panel, you can further optimize the quality of your job.

Change the original type for color or grayscale. Use the overview to select the correct type.

Original types for color

- When you move from original types [Photo] to [Folded lines/text], line enhancement and contrast enhancement are increased, while folds and background are more suppressed.
- When you move from original types [Folded lines/text] to [Photo] the color accuracy is increased.

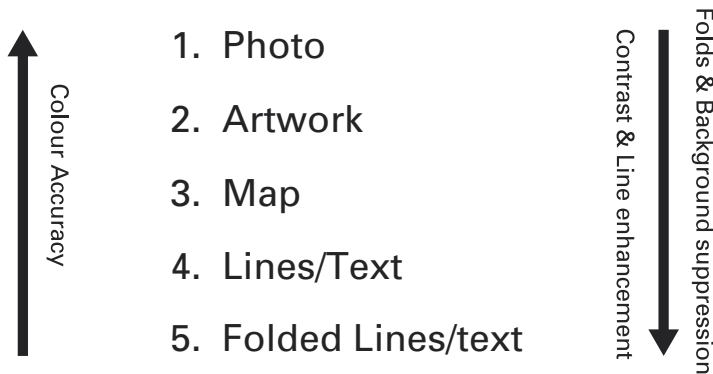

Original type	Definition
[Photo]	Used for photos and high resolution prints. Photo gives a softer contrast than artwork.
[Artwork]	Used for artwork-like colored originals with more defined color areas and transition between colors.
[Map]	Used for originals with large color areas, that also include lines and finer details.
[Lines/text]	Used for CAD drawings.
[Folded lines/text]	Used for CAD drawings with folds. Lines and wrinkles are suppressed.

Original types for grayscale

Original type	Definition
[Lines/text]	Used for monochrome CAD drawings.
[Colored original]	Used for most colored originals, such as colored CAD drawings.
[Photo]	Used for photos and high resolution prints. Photo gives a softer contrast than colored original.

Original type	Definition
[Dark original]	Used especially for Diazo originals. Originals with a changing 'cloudy' background.
[Folded lines/text]	Used for monochrome CAD drawings with folds. Lines and wrinkles are suppressed. For folded color CAD drawings use [Colored original].
[Blueprint]	Used for classic blueprints, with white information on a blue background.

Make a half size copy

Introduction

When you want to scale your original to a 50% copy, you can change a preset on the user panel.

Procedure

1. Feed the original face up and centered on the original feeding table.
2. Tap the copy tile. A window with a list of presets opens.
3. Tap the [Layout] preset.

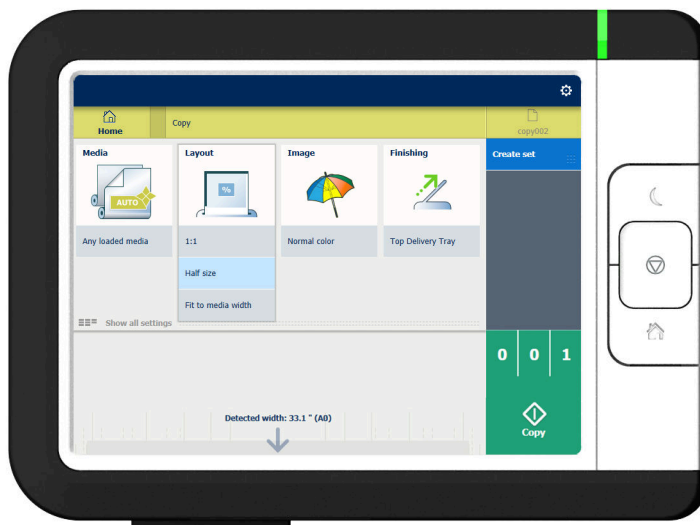

4. Tap [Half size].
5. Define the number of copies and tap the green button.

Result

The printer copies to 50%.

Make a copy and add a strip

Introduction

When you make a copy, you can add a strip to a document.

Use [Cut size] to copy an original without a strip and add a strip to the copy. You can add a strip at the top or bottom of a copy.



NOTE

For more information on the cut size settings, see [Advanced settings for copy jobs on page 224](#).

Procedure

1. Feed the original face up and centered on the original feeding table.
2. Tap the copy tile. A window with a list of presets opens.
3. Tap [Show all settings]. A list with settings opens.
4. Tap [Cut size] under the [Layout] preset.



5. Tap [Add a leading strip] or [Add a trailing strip] and define the values.
6. Make your settings and tap [OK].
7. Define the number of copies and tap the green button.

Result

The document is printed with a strip attached to the top or bottom.

Make a copy and remove a strip

Introduction

When you have an original with a part you do not want to copy, you can remove a strip from your copy.

Use the option on the user panel to copy an original with a strip, and remove the strip from the copy. You can remove a strip from the top, the bottom, the left or the right side of the original.



NOTE

- For more information on the cut size settings, see [Advanced settings for copy jobs on page 224](#).
- You can also use this setting to copy a specific area of the original. For more information, see [Make a copy of a specific area of an original on page 241](#).

Procedure

1. Feed the original face up and centered on the original feeding table.
2. Tap the copy tile. A window with a list of presets opens.
3. Tap [Show all settings]. A list with settings opens.
4. Tap [Remove strip] under the [Layout] preset.

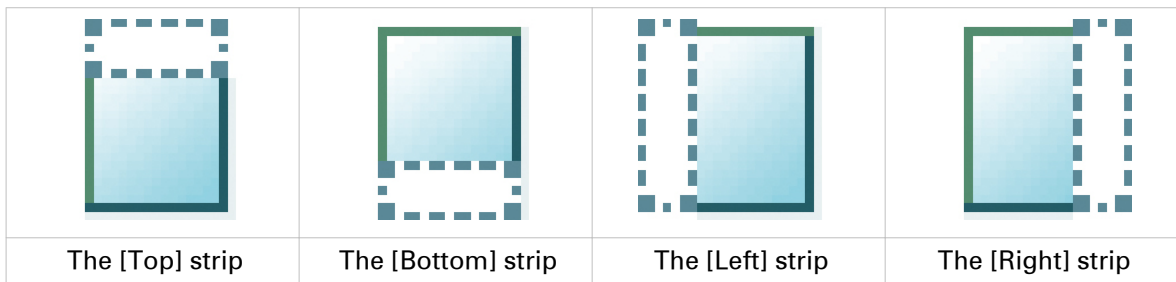

5. Select [Top], [Bottom], [Left], or [Right] and define the values.
6. Make your settings and tap [OK].
7. Define the number of copies and tap the green button.

Make a copy of a specific area of an original

Introduction

You can make a copy of a specific area of an original. Use the option [Remove strip] to copy a specific area.



NOTE

For more information on the cut size settings, see .

Procedure

1. Feed the original face up and centered on the original feeding table.
2. Tap the copy tile. A window with a list of presets opens.
3. Tap [Show all settings]. A list with settings opens.
4. Tap [Remove strip] under the [Layout] preset.

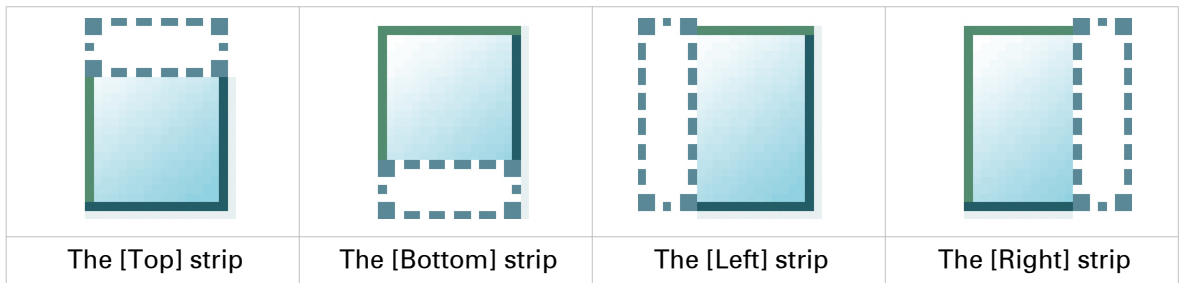

5. Select [Top], [Bottom], [Left], or [Right], and define the values for your specific area.
6. Make your settings and tap [OK].
7. Tap [Positioning] and then [Alignment].
8. Select [Center] from the list and tap [OK].
9. Define the number of copies and tap the green button.



Make a copy and remove a specific area of an original

Introduction

You can make a copy and delete a specific area of an original. You can use two settings: [Area to erase: width] and [Area to erase: length] to define the dimensions of the delete area. And you can use two settings: [Area to erase: X origin] and [Area to erase: Y origin], to define the relative position of the delete area on the sheet.

Procedure

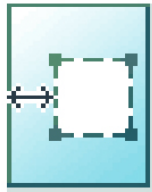
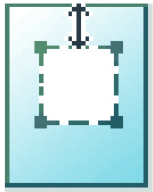
1. Feed the original face up and centered on the original feeding table.
2. Tap the copy tile. A window with a list of presets opens.
3. Tap [Show all settings]. A list with settings opens.
4. Tap [Area to erase] under the [Image] preset.

			
[Area to erase: X origin]	[Area to erase: Y origin]	[Area to erase: width]	[Area to erase: length]

5. Select [Area to erase: X origin], [Area to erase: Y origin], [Area to erase: width], or [Area to erase: length] and define the values for your specific area.
6. Make your settings and tap [OK].
7. Define the number of copies and tap the green button.

Make a copy and scale to another size

Introduction

When you want to scale your copy to another size, you can make changes under the advanced settings. With the custom setting, you can choose any scale percentage you want between the range of 10 - 1000%.



NOTE

For more information on the other scale modes, see [Advanced settings for copy jobs on page 224](#).

Procedure

1. Feed the original face up and centered on the original feeding table.
2. Tap the copy tile. A window with a list of presets opens.
3. Tap [Show all settings]. A list with settings opens.
4. Tap [Scale] under the [Layout] preset.
5. Tap [Scale] in the new window and select [Custom].
6. Under [Custom] select any percentage between 10 - 1000%.
7. After you made your settings tap [OK].
8. Enter the number of copies and tap the green button.

Make a copy of a dark original (Diazo)

Introduction

It can be difficult to make a good copy of a Diazo original. Diazo originals have a changing lightness with a 'cloudy' background, which can give an unclear output. The ColorWave 3600 has a special [Diazo] preset, that follows the lightness and changing background of the original and copies to an even and high quality output.

Before you begin

Use the [Diazo] mode for originals that have a changing 'cloudy' background.

Dark and light Diazo originals, or other light or dark originals with a changing background can be copied in [Diazo] mode.

Procedure

1. Feed the original face up and centered on the original feeding table.
2. Tap the copy tile. A window with a list of presets opens.
3. Tap the [Image] preset.
4. Tap [Diazo].
5. Define the number of copies and tap the green button.

Make a copy of an original with highlighted colors

Introduction

When you have an original on which colors are accentuated or highlighted, it can be difficult to make a good copy on which the highlighting is still visible. The ColorWave 3600 has a special setting [Color highlighting], that highlights the color accents of the original in black and white or color. The copy has the same accents and quality as the colored original.



NOTE

- When the [Color mode] is set to [Color], color highlighting will make the colors more saturated.
- When the [Color mode] is set to [Grayscale], colors will be copied darker than the grayscale information on the original.
- The setting is disabled for the original types, [Photo], [Artwork], [Blueprint].

Procedure

1. Feed the original face up and centered on the original feeding table.
2. Tap the copy tile. A window with a list of presets opens.
3. Tap [Show all settings]. A list with settings opens.
4. Tap [Image] under the [Image] preset.
5. Tap [Color highlighting].
6. Select [On] and tap [OK].
7. Define the number of copies and tap the green button.

Copy by set

Introduction

You can use the [Create set] option to make multiple scans and copy in one set.

Procedure

1. Feed the original face up and centered on the original feeding table.
2. Tap the copy tile. A window with a list of presets opens.

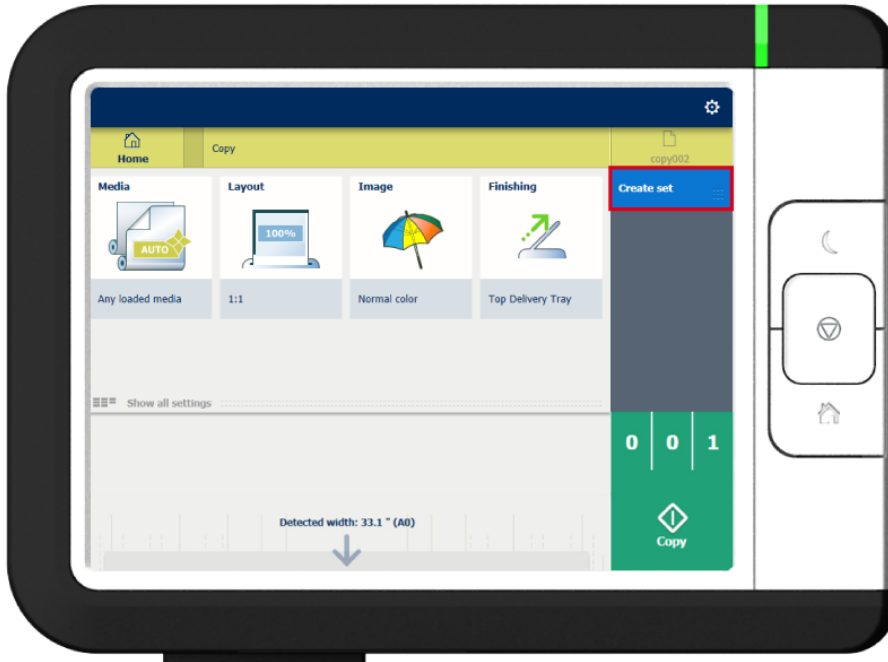

3. In the job pane on the right, tap [Create set].
The green button changes color and displays [Add].
4. Tap the green button to start scanning.
5. When the printer releases the original, insert the next original.
6. Tap the green button. The scan is added to the set.
Repeat this step until your set is complete.
7. Tap the [Finish set] tile to finish the set.

Result

The printer copies the set of originals.

Scan Jobs

Do a default scan job

Introduction

When you want to scan an original and you do not make any settings the default templates are used. You only use the Smart Access to submit your job.

You can see an overview of the template settings that are used in the job settings section of your job.

Procedure

1. Feed the original face up and centered on the original feeding table.
2. Select the scan tile on the user panel. The scan Smart Access is visible.



3. Select the preferred template in the Smart Access and tap the green button.



NOTE

Tap on [Release the original] under the Smart Access to release your original from the scanner.

Result

A scan to file is made, and sent to the location defined in the template.

You can also see the job under [Recent scans] on the user panel. Open it to view or print the file.

Scan templates on the user panel

Introduction

A template is a group of predefined settings you can configure yourself. Select the template on the user panel to easily submit a job with optimized settings.

Scan template workflow

The printer uses the scan templates that are configured in WebTools Express. Several templates are factory installed and by default visible on the user panel. Customize the use of templates to your needs first:

- Create a new template. For more information, see [Create a new template on page 111](#).
- Make templates available on the user panel. For more information, see [Enable or disable scan templates on page 116](#).

Then feed the original in the scanner. Tap the scan tile.

Select the template in the Smart Access. Note that the scan destination is defined in the template as well.

Advanced settings for scan jobs

Introduction

When you tap the scan tile on the multi-touch user panel, you can select a template.

When you select a template and tap it again, a window with all settings opens. The following table gives an overview and a short description of the available settings on the printer. You can find a detailed description of each setting in WebTools Express.





NOTE

The values for the compression mode and organization change depending on the color mode and file type you select. In some situation and for some file types you cannot set the compression and organization settings. For more information on this, see [File type on page 259](#).





Category: [File]





Setting	Settings values	Settings values	Function
[File type]	[File type]	[TIFF] [PDF] [PDF/A] [JPEG] [CAL5]	[The file type of the scanned image. The list of file types depends on scan to color, grayscale, or black-and-white: CAL5 is only available when scanning to black-and-white; JPEG is not available when scanning to black-and-white.] 
	[Compression]	[Automatic] [LZW] [Flate] [Packbits] [JPEG] [None]	The compression type when scanning to TIFF or to PDF depends on the chosen [File type].
	[JPEG quality]	[Maximum] [High] [Medium] [Low]	[The image quality when scanning to JPEG. With a lower quality, the compression increases giving a smaller file size.]
	[Organization]	[Raw] [Striped] [Tiled]	[The file organization when scanning to TIFF.]

Setting	Settings values	Function
[Resolution]	[100] [200] [300] [400] [600]	[The resolution of the scanned image in dpi.] 
[Color mode]	[Color] [Grayscale] [Black and white]	[Defines whether a color, grayscale or black-and-white scan is to be made. Some combinations of "Color mode" and "File type" are invalid: changing "Color mode" may reset "File type", "Compression for TIFF" and "Compression for PDF".] 

Category: [Original]

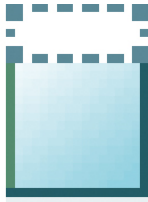
Setting	Settings values	Function
[Original type]	[Folded lines/text] [Lines/text] [Map] [Colored original] [Artwork] [Photo] [Blueprint] [Dark original]	Define the type of original you use. The choice depends on the chosen [Color mode]. For more information on choosing the correct original type, see . 

Setting	Settings values	Function
[Original width]	[Auto]	<p>The width of the original is automatically detected by the scanner.</p> 
	[Standard]	<p>The width of the original is a standard size. Selection of available standard sizes.</p>  <p> NOTE Depends on the media type and size you have configured in WebTools Express</p>
	[Custom]	<p>The width of the original is a custom size. You can enter a size within the range of 210 to 914 mm, or 8.5 to 36 inches.</p> 

Setting	Settings values	Function
[Remove strip]	[Remove top strip]	[Erase a strip from the beginning of the original.] From 0 to 400 mm, or 0 to 16 inches. 
	[Remove bottom strip]	[Erase a strip from the bottom of the original.] From 0 to 400 mm, or 0 to 16 inches. 
	[Remove left strip]	[Erase a strip from the left side of the original.] From 0 to 400 mm, or 0 to 16 inches. 
	[Remove right strip]	[Erase a strip from the right side of the original.] From 0 to 400 mm, or 0 to 16 inches. 
[Mirror]	[On] [Off]	[When "On", the image is mirrored along the vertical axis (the media transport direction).] Set to [On] for strongly curled transparent originals that have to be fed upside down in the scanner. Or for (dark) transparent originals that have the information printed on the back. 

Category: [Quality]

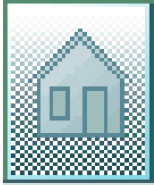
Setting	Settings values	Function
[Scan quality]	[Automatic] [Normal] [High]	<p>Define the quality of the scan.</p> <ul style="list-style-type: none"> • [Automatic] is the default value that automatically selects the best scan quality value for your job. • Select [High] to scan with a higher resolution. This can prevent a moiré pattern for originals that contain gray or colored areas. • Select [Normal] if print productivity is an important factor. For pure CAD originals [Normal] is mostly sufficient.
[Lighter/Darker]	Value from -5 to 5	<p>Define the lightness and the contrast of a scan. Increase the value for lighter prints, and decrease for darker prints.</p> <p>When you make a scan darker, the information becomes darker while the background is less affected. When you make a scan lighter, weak information is not clipped to white.</p>
[Background compensation]	[On] [Off] [Automatic]	<p>Reduce the background noise of the image.</p> <ul style="list-style-type: none"> • Default is [Automatic]. Dependent of the chosen [Original type], background compensation is automatically applied or not. • Override [Automatic] by selecting [On] or [Off]. <p>The applied background compensation method depends on the chosen original type.</p> 

Setting	Settings values	Function
[Color highlighting]	[On] [Off]	<p>Set to [On]</p> <ul style="list-style-type: none"> to make notes made with marker pens more visible. to emphasize colors, of a CAD drawings with colored information and a solely grayscale (black) background information. <p> NOTE</p> <ul style="list-style-type: none"> When the [Color mode] is set to [Color], color highlighting will make the colors more saturated. When the [Color mode] is set to [Grayscale], colors will be scanned darker than the grayscale information on the original. The setting is disabled for the original types, [Photo], [Artwork], [Blueprint].

Category: [Workflow]

Setting	Settings values	Function
[Destination]	[Type]	Select the location you want to scan to. For more information, see Configure your locations on page 117
[Scan name]		Use the keyboard to change the scan file name.
[Check print]	[On] [Off]	Set to [On] to make a print of your scanned image.

Advised settings for scan jobs

Introduction

When you use a certain type of original document you can select specific templates and settings that influence the quality and productivity of your job. Use the advised settings in the table below to get the best results.

Workflow

1. Start by selecting the best template for your job. Use the table below for the factory installed scan templates.
Eleven scan templates are factory installed on the system, and you can create new scan templates in WebTools Express. The first five factory installed templates are available on the user panel after installation. You can enable or disable the templates via WebTools Express. For more information, see [Create a new template on page 111](#) and [Enable or disable scan templates on page 116](#).
2. When you then want to further optimize the settings, you can select the advanced settings when you tap the scan tile on the user panel. When you want to influence the imaging process and thus optimize the output quality, you can select the corresponding [Original type] for your job. For more information, see [Advanced settings for scan jobs on page 249](#) and [The original type on page 257](#).

Advised settings

Scan template	Original document
01 - Fast CAD B/W	Black and white CAD drawings, when productivity or a small file size is an important factor. Line information is enhanced and background is suppressed. For black and white CAD originals with large area fills, choose the [CAD B/W] template.
02 - CAD B/W	Black and white CAD drawings, when quality is an important factor. Line information is enhanced and background is suppressed.
[03 - Fast Color]	Productive scanning of a wide range of colored originals. For originals with large area fills, choose the [Color] template.
04 - Color	Almost all originals, to make a good quality color scan. The quality settings are balanced between color accuracy and the enhancement of fine information, while background is being suppressed.
[05 - CAD color]	Color CAD drawings, when quality and file size is an important factor. Line information is enhanced and background is suppressed. When you have a CAD original with large area fills, choose the [Color] template.
[06 - Fast CAD color]	Color CAD drawings, when productivity or file size is an important factor. Line information is enhanced and background is suppressed. When you have a CAD original with large area fills, choose the [Color] template.
[07 - Diazo B/W]	CAD original with a varying background, like a Diazo original or a Chinese blueprint, to make a black and white scan.

Scan template	Original document
[08 - CAD with foldings]	Folded monochrome CAD original, to make a black and white scan.
[09 - CAD color to B/W]	Color CAD drawings, maps, business graphics etc., to make a black and white scan.
[10 - CAD color + highlight]	Color CAD drawings with marks from marker pens. Colors become more saturated.
[11 - Photo color]	Photo-like originals with high color accuracy.

The original type

Introduction

When you tap the scan tile and select the [Original] - [Original type] setting on the user panel, you can further optimize the quality of your job.

Change the original type for color or grayscale. Use the overview to select the correct type.

Original types for color

- When you move from original types [Photo] to [Folded lines/text], line enhancement and contrast enhancement are increased, while folds and background are more suppressed.
- When you move from original types [Folded lines/text] to [Photo] the color accuracy is increased.

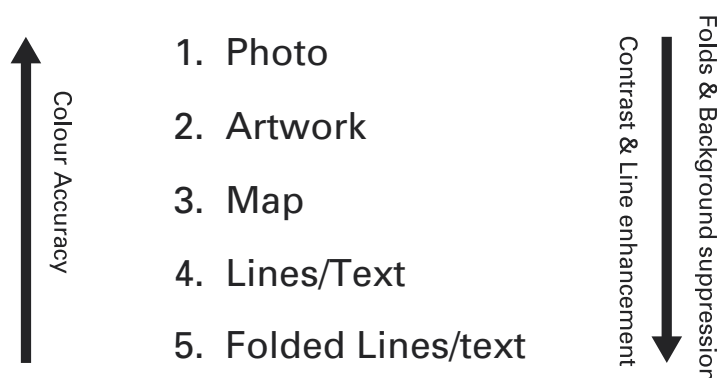

Original type	Definition
[Photo]	Used for photos and high resolution prints. Photo gives a softer contrast than artwork.
[Artwork]	Used for artwork-like colored originals with more defined color areas and transition between colors.
[Map]	Used for originals with large color areas, that also include lines and finer details. For a wide range of originals this mode is the best balance between color accuracy and line enhancement.
[Lines/text]	Used for CAD drawings. Line information is enhanced and background is suppressed.
[Folded lines/text]	Used for CAD drawings with folds. Lines and wrinkles are suppressed.

Original types for grayscale

Original type	Definition
[Lines/text]	Used for monochrome CAD drawings.
[Colored original]	Used for most colored originals, such as colored CAD drawings. ▶

Original type	Definition
[Photo]	Used for photos and high resolution prints. Photo gives a softer contrast than colored original.
[Dark original]	Used especially for Diazo originals. Originals with a changing 'cloudy' background.
[Folded lines/text]	Used for monochrome CAD drawings with folds. Lines and wrinkles are suppressed. For folded color CAD drawings use [Colored original].
[Blueprint]	Used for classic blueprints, with white information on a blue background.

File type

Introduction

Depending on the color mode and file type you select when you create a scan template or when you make a scan, the values for the compression mode and organization change. For some file types and some situations, the compression and organization settings cannot be set. The list below helps you to define the correct file type and color mode, and shows you which compression and organization settings are possible.



NOTE

On the user panel and in WebTools Express you can set an automatic compression value. The controller determines the most common compression method for the file type that is selected. The automatic compression value can be found:

- on the user panel under the scan tile. Tap the scan tile twice and select [File type].
- in WebTools Express in the scan templates.

Set the compression to automatic under:

- [PDF compression] (when PDF is selected)
- [PDF/A compression] (when PDF/A is selected)
- [TIFF compression] (when TIFF is selected)

Color mode: Color

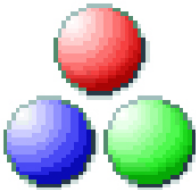
[Color mode]	[File type]	[Organization]	[Compression]	[JPEG quality]
[Color] 	[TIFF]	[Raw] [Striped] [Tiled]	[LZW] [Packbits] [None]	Not applicable
	[PDF]	Not applicable	[Flate] [LZW] [None]	Not applicable
			[JPEG]	[Maximum] [High] [Medium] [Low]
	[PDF/A]	Not applicable	[Flate] [None]	Not applicable
			[JPEG]	[Maximum] [High] [Medium] [Low]
	[JPEG]	Not applicable	Not applicable	[Maximum] [High] [Medium] [Low]

Color mode: Grayscale

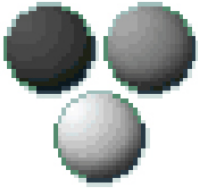
[Color mode]	[File type]	[Organization]	[Compression]	[JPEG quality]
[Grayscale] 	[TIFF]	[Raw] [Striped] [Tiled]	[LZW] [Packbits] [None]	Not applicable
	[PDF]	Not applicable	[Flate] [LZW] [None]	Not applicable
			[JPEG]	[Maximum] [High] [Medium] [Low]
	[PDF/A]	Not applicable	[Flate] [None]	Not applicable
			[JPEG]	[Maximum] [High] [Medium] [Low]
[JPEG]	Not applicable	Not applicable	[Maximum] [High] [Medium] [Low]	

Color mode: Black and White

[Color mode]	[File type]	[Organization]	[Compression]	[JPEG quality]
[Black and white] 	[TIFF]	[Raw] [Striped] [Tiled]	[Group 4] [Group 3] [Packbits] [None]	Not applicable
	[PDF]	Not applicable	[Group 4] [LZW] [Flate] [None]	Not applicable
	[PDF/A]	Not applicable	[Group 4] [Flate] [None]	Not applicable
	[CALS]	Not applicable	Not applicable	Not applicable

Make a scan and remove a strip

Introduction

If you have an original with a strip, you can remove the strip from your scanned file.

Use the option [Remove strip] on the user panel to scan an original with a strip and remove the strip from the file. You can remove a strip from the top, the bottom, the left or the right side of the original.

Procedure

1. Feed the original face up and centered on the original feeding table.
2. Tap the scan tile on the user panel and select your preferred template in the scan Smart Access.
3. Tap the scan tile again.
4. Tap [Remove strip] under the [Original] category.

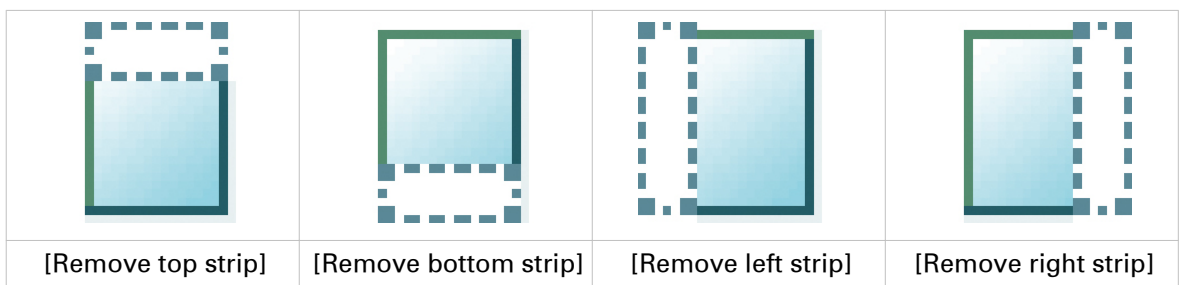

5. Select [Remove top strip], [Remove bottom strip], [Remove left strip], or [Remove right strip] and define the values.
6. Make your settings and tap [OK].
7. Tap the green button.

Result

The printer scans the original to file without the defined strip. The file is sent to the location defined in the template.

Scan to a USB key

Introduction

When you insert a USB key in the user panel, you can scan to USB.

Before you begin

- Before you scan to USB, make sure the correct settings are enabled. For more information see, [Enable or disable USB on page 118](#).
- You can create a template with USB as destination to easily submit your job. For more information, see [Create a new template on page 111](#).

Procedure

1. Feed the original face up and centered on the original feeding table.
2. Insert a USB key into the USB port on the user panel.
The scan tile is automatically selected on the user panel. Select a template with USB as destination or change the destination to USB.
3. Tap the green button to start the scan job.



NOTE

Wait until the light in the USB port stops blinking, before you retract the USB key.

Result

A scan to file is made, and saved on your USB key. You can retrieve the file from your USB key.

Scan to the home folder

Introduction

When you have enabled user authentication in WebTools Express you can submit a print or scan job to the home folder as a secure location.



NOTE

The Home folder is a personal and secure external location, you can only use when it is configured by your IT department as part of your infrastructure.

Before you begin

Enable [User authentication] with [User name and password] configured and enable the home folder as a location first. For more information, see [Enable and edit the Home folder on page 119](#).

Procedure

1. Log in on the printer user panel using your credentials [User name and password].
2. Feed the original face up and centered on the original feeding table.
3. Select the scan tile.
4. Select a template with home folder as destination or change the destination to home folder.
5. Tap the green button to start the scan job.

After you finish

The file is delivered on your own personal location on the network. In a typical configuration you can find the file on your workstation under the home drive.

Save a scanned document on your mobile device

Introduction

When you have access to Publisher Express you can scan a document on the printer and save it on your mobile device.

Before you begin

Make sure you have a working connection.

Procedure

1. Feed the original face up and centered on the original feeding table.
2. Select the scan tile on the user panel. The scan Smart Access is visible.
3. In the Smart Access, select the preferred template and make sure a Smart Inbox is set as destination.
4. Tap the green button.
The scanned file is sent to the selected Smart Inbox and is visible in WebTools Express and in Publisher Express.
5. Open Publisher Express on your mobile device.
6. Open the preferred Smart Inbox section. The scanned file is displayed here.
The Smart Inbox section is automatically refreshed within a few seconds.
7. Select the file and click on the Save icon.
8. Browse to a folder on your mobile device, and click Ok.



NOTE

The stored location or folder is sometimes determined by the browser on your mobile device.

Some mobile device browsers change the name, or the extension of the file while storing it.

Result

The file is stored on your mobile device.

Click the “delete” icon if you want to delete the file from the inbox on the printer.



Pause, resume, or stop an active job

Introduction

If you want to pause, resume or stop an active job there are several things you can do.

Procedure

Pause or resume an active print job

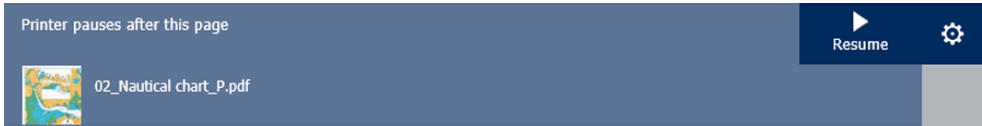
Step	Action
1.[Pause]	<p>Tap on the active job in the dynamic bar of the user panel. The queue opens and [Pause] is visible in the dynamic bar. Tap [Pause] to pause the printer. The [Pause] tile turns into a [Resume] tile.</p> <p> NOTE Note that running prints are finished by the printer, so it might take a moment for the printer to pause.</p> 
2.[Resume]	<p>Tap [Resume] in the dynamic bar to resume the printer.</p> 

Stop and delete an active job on the user panel

Step	Action	Result
1	Press the stop button.	For scan jobs: the machine stops scanning immediately.
2	For print jobs: a dialog box appears asking if you want to delete the job.	Your print job is saved or deleted.
3	For print jobs: a dialog box appears asking if you want to delete the job from the Smart Inbox.	Your print job is saved or deleted.
4	For copy and scan jobs: tap on [Release the original] under the Smart Access, to release your original from the scanner.	The scanner releases the original.

Stop and delete an active job in WebTools Express

Step	Action	Result:
1	Open the [Jobs] tab.	
2	In the Job queue section tick the box in front of the job you want to delete and click [Delete].	The system aborts and deletes the job.

Clear the system

When to do

On the user panel, you can remove all print and copy jobs from the system.

Procedure

1. Tap on the system menu thumbnail in the dynamic bar. The system menu opens.
2. Tap on [Clear system] in the list in the right part of the display. A wizard opens.

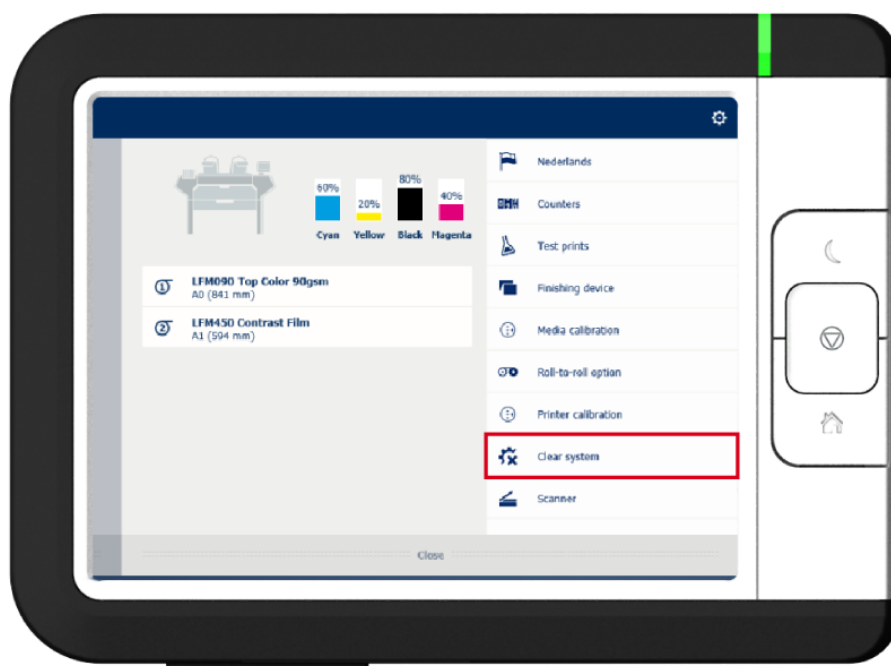

NOTE

Make sure you have saved all the information. All print and copy jobs are removed.

3. Follow the steps in the wizard and complete the procedure.

Result

After you have followed the steps, the system will reboot and all print and copy jobs are removed.

Chapter 5

Maintain the printing system

Update your system

Update the software

You can update the system software when requested by service or your local representative. Install system patches for security when they are available for your product on "<http://downloads.cpp.canon>". You can update via the user panel or via WebTools Express.

Update	Location
System software	User panel or WebTools Express
System patches (security)	WebTools Express

Update the system software on the user panel

Introduction

You can update the system software on the user panel with a USB device that includes a new version of the software.

Before you begin

For an update of the system software, get the packages for the system software update from your local representative.

You need a NTFS formatted USB device. Make sure the update files ([Open source package (*_os.sup)] and [Software package (*_sw.sup)]) are present under the [USB:\Packages] directory of the USB device.



NOTE

- The update process deletes all jobs on the system.
- During the update process the system is unavailable for approximately 20 minutes.
- The update contains a complete update of the operating system. As a result, all installed third-party applications will be erased. You can reinstall the third-party applications after the update.

Procedure

1. Tap the system menu thumbnail on the user panel. The system menu opens.
2. Tap on [System update] in the setup menu.
3. Log in as a System administrator or Power user. The update wizard appears.
4. Insert the USB device into the USB port on the user panel.
5. Follow the instructions of the wizard.
During the update the system is not available. When the update is finished, the printer will restart.
6. Remove the USB device before the printer restarts.

After you finish

You can check the current software version under System menu - [System update] on the user panel, or under the [Support] - [Update] tab in WebTools Express.

Update the system software in WebTools Express

Introduction

You can update the system via WebTools Express. You can find the settings under the [Support] - [Update] tab.

The [Update] tab has the following functionalities:

- **update** the system software
- **install** system patches (security)
- check the current software version
- check the execution status of the latest patch applied ('Success' or 'Failure').

Before you begin

For an update of the system software, get the packages for the system software update from your local representative.



NOTE

- Do not restart the printer during the upload and update process.

Procedure

1. Select the [Support] - [Update] tab.
2. Click on the [Update] button for an update of the current system software.
3. Browse to the packages you need ([Open source package (*_os.sup)] or [Software package (*_sw.sup)]).
Select the files you need and click 'Open'.
4. Click [Ok] to confirm, or [Cancel] to reject your entries.
5. You are now ready to update the software. A warning message appears.
Click [Ok] to confirm, or [Cancel] to reject your entries.
6. The update starts. At the end of the process, the controller restarts.
Click [Ok] to open WebTools Express.
7. You are informed whether the update was successful.

Install the system security patches in WebTools Express

Introduction

You can install system security patches in WebTools Express.

Before you begin

Download the system security patches from "<http://downloads.cpp.canon>".



NOTE

- Do not restart the printer during the upload and update process.

Procedure

1. Select the [Support] - [Update] tab.
2. Click on the [Install] button for an installation of the system patches.
3. Browse to the location of the [Operating system patch file (*.msu)].
Select the file and click 'Open'.
4. Click [Ok] to confirm, or [Cancel] to reject your entries.
5. You are now ready to install the patches. A warning message appears.
Click [Ok] to confirm, or [Cancel] to reject your entries.
6. The installation starts. At the end of the process, the controller restarts.
Click [Ok] to open WebTools Express.
7. You are informed whether the installation was successful.

Replace the media

The media drawer

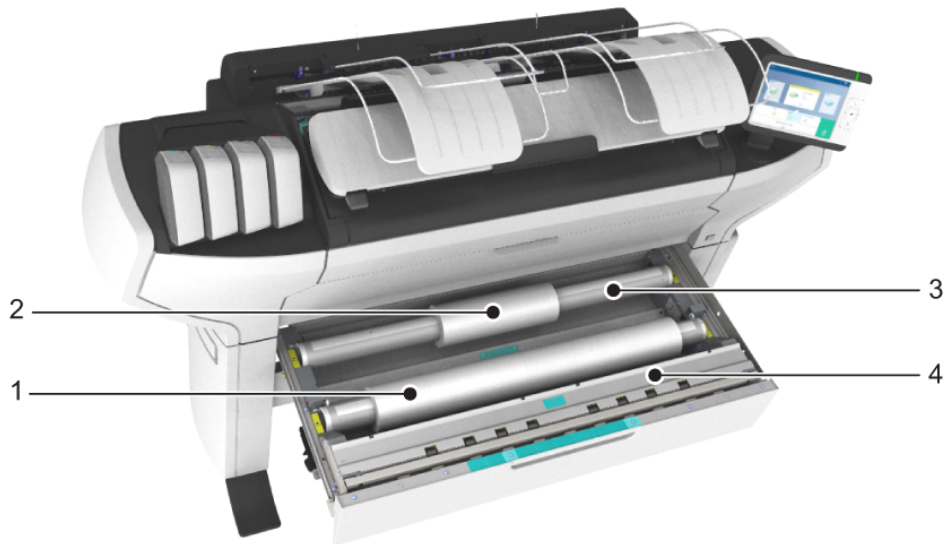

Component - function table



IMPORTANT

Only use intact media rolls. Dented media rolls can damage the [Imaging devices].

No	Component	Description / Function
1	[media roll] 1	Media placed on roll holder in first position.
2	[media roll] 2	Media placed on roll holder in second position.
3	[roll holder]	Carries the media roll.
4	[roll loading station]	Groove integrated behind the front cover of the media drawer.

Remove a media roll



IMPORTANT

- Handle the media roll with care. A dented media roll can damage the printer.
- Do not open the media drawer during the printing process.



CAUTION

- Watch your fingers when you handle the media roll.
- If you want to remove an A0 media roll from position 2, make sure to bend your knees, as indicated below, to spare your back.



Procedure

1. Pull firmly on the media drawer to open it.



2. Roll the media back manually, to remove the media from the metal paper guide.

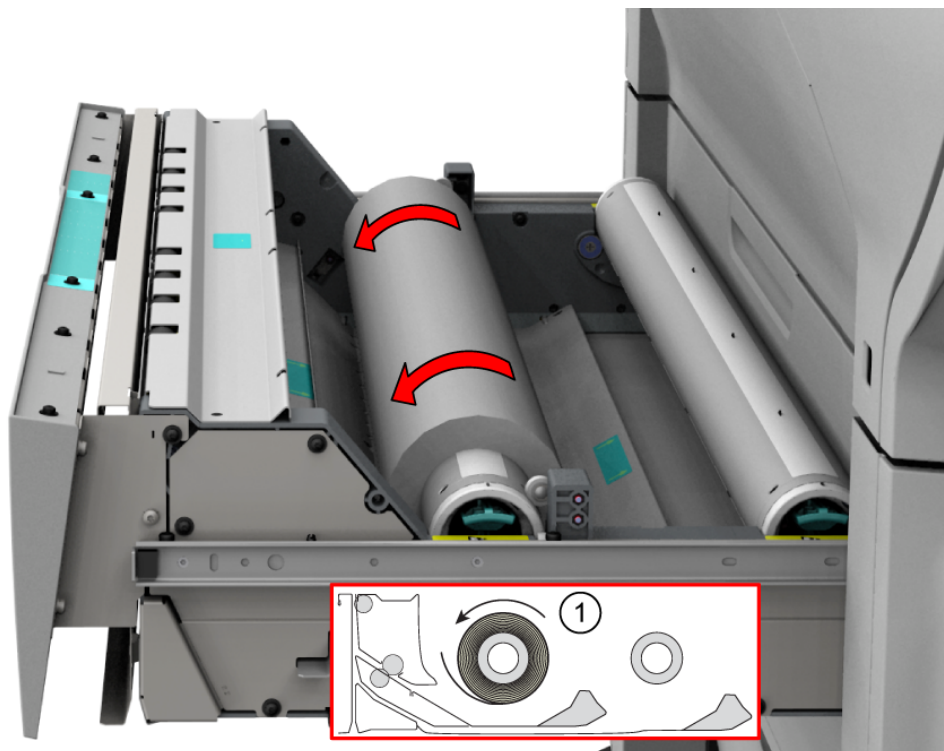

3. Use both hands (as indicated) to lift the roll holder with the media roll and put it on the roll loading station.

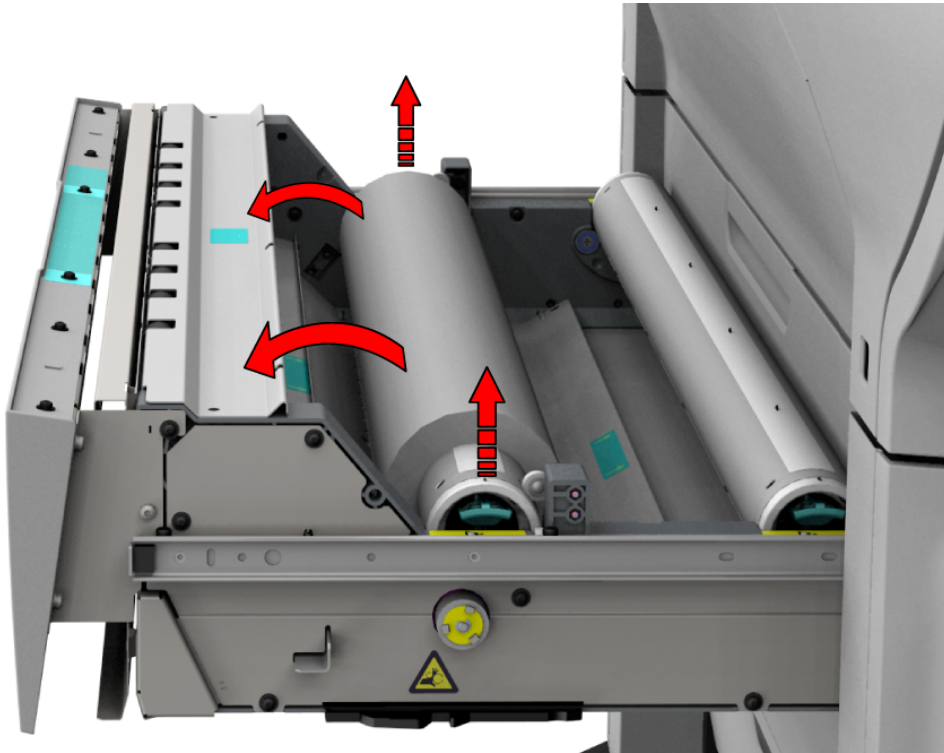

4. Pull the handle of the roll holder locking mechanism towards you and remove the roll holder from the core of the media roll.
Put the empty roll holder back into the drawer (as shown in the illustrations)

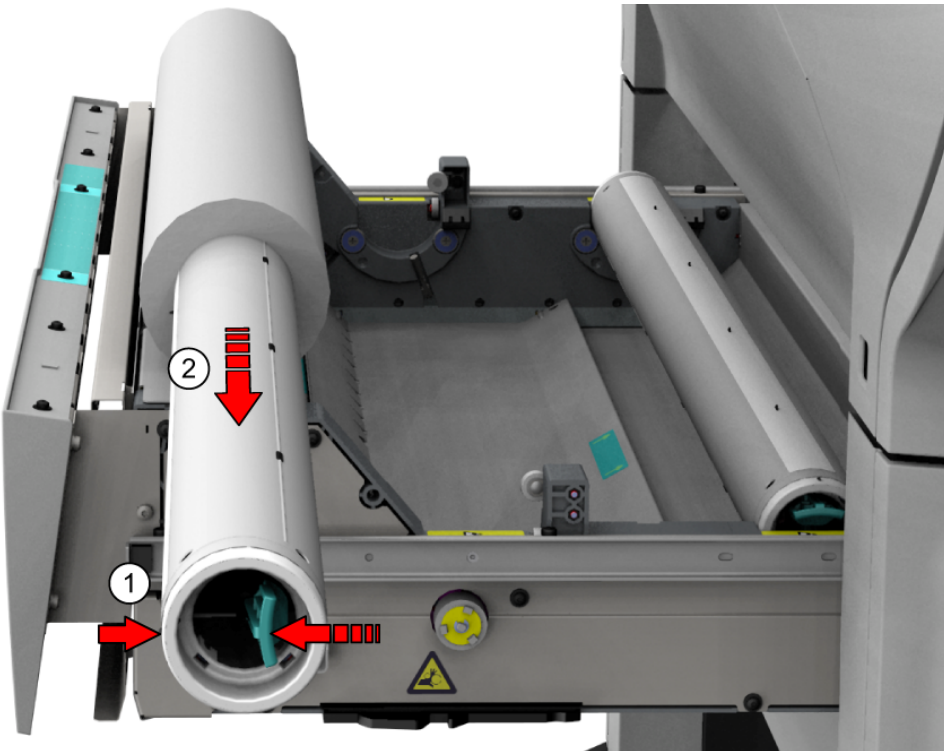

5. Remove the media roll from the roll loading station.
Store it in a safe place, so that it cannot fall over or roll away.

Unpack a media roll



IMPORTANT

- Handle the media roll with care. A dented media roll can damage the printer.
- Always write the correct media name inside the core, after you unpack the media roll. This way, you will have the correct media information available if you replace the roll before it is empty and you want to reuse it later,.

Procedure

1. Place the media box on a table.

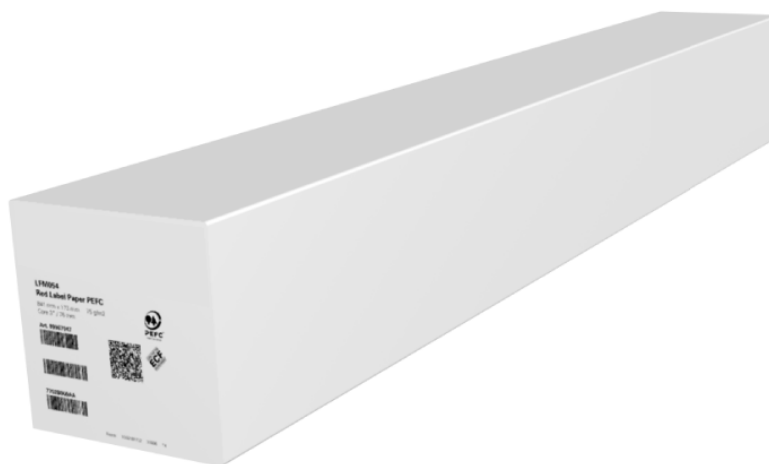

2. Open the box, and if present remove the plug.

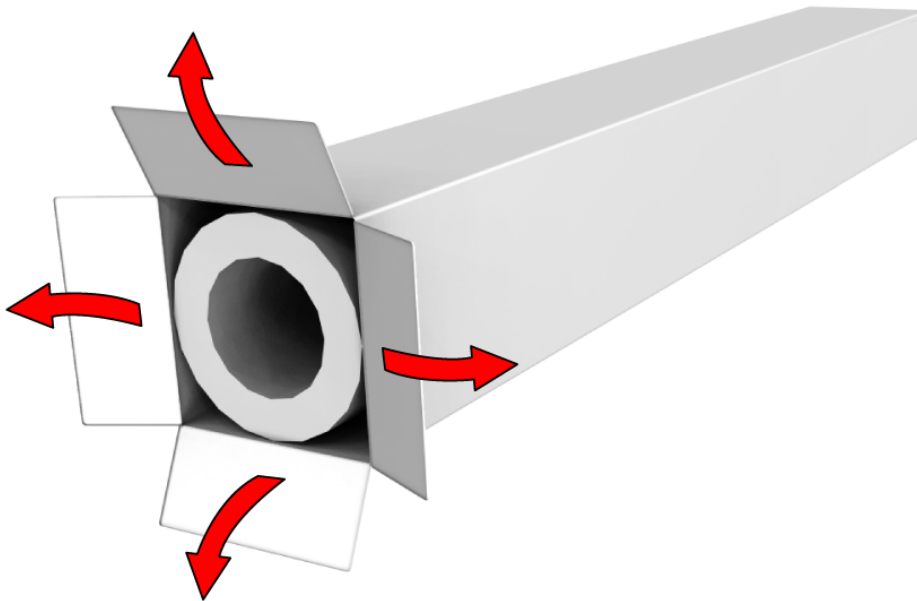

3. Carefully remove the media roll from the box.

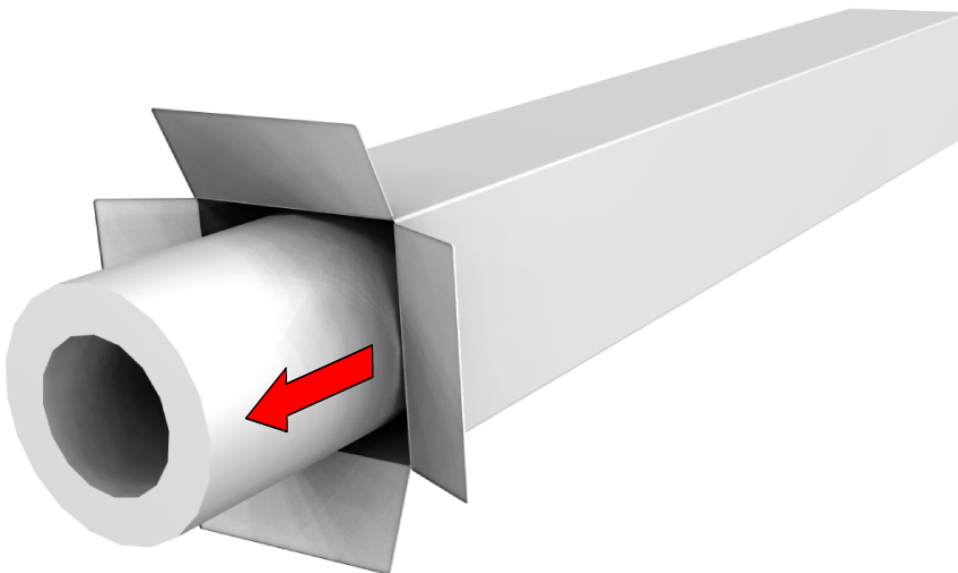

4. If present, remove the other plug and any plastic on the media roll.

Load a media roll

Introduction

You can load standard and custom media on your printer.

Before you begin

Before you load a roll on the printer, make sure your media has been configured.

- For standard media you can configure and enable a media profile in WebTools Express. For more information, see [Configure the media profiles on page 180](#).
- Make sure the size is configured and enabled in WebTools Express. For more information, see [Configure the media sizes on page 183](#). If your media size is not present in the list, you can create a custom media size. For more information, see [Create a custom media size on page 182](#).



IMPORTANT

- Do not use dented media rolls to prevent damage to the imaging devices.
- Do not open the media drawer during the print process.
- Do not open more than one media drawer at the same time to prevent overbalance of the printer.



CAUTION

Watch your fingers when you handle the media roll.

Procedure

1. Pull firmly to open the media drawer.



2. Place the new media roll on the roll loading station.

3. Pull (1) the handle of the roll holder locking mechanism toward you.
Slide (2) the roll holder into the right side of the core of the new media roll.

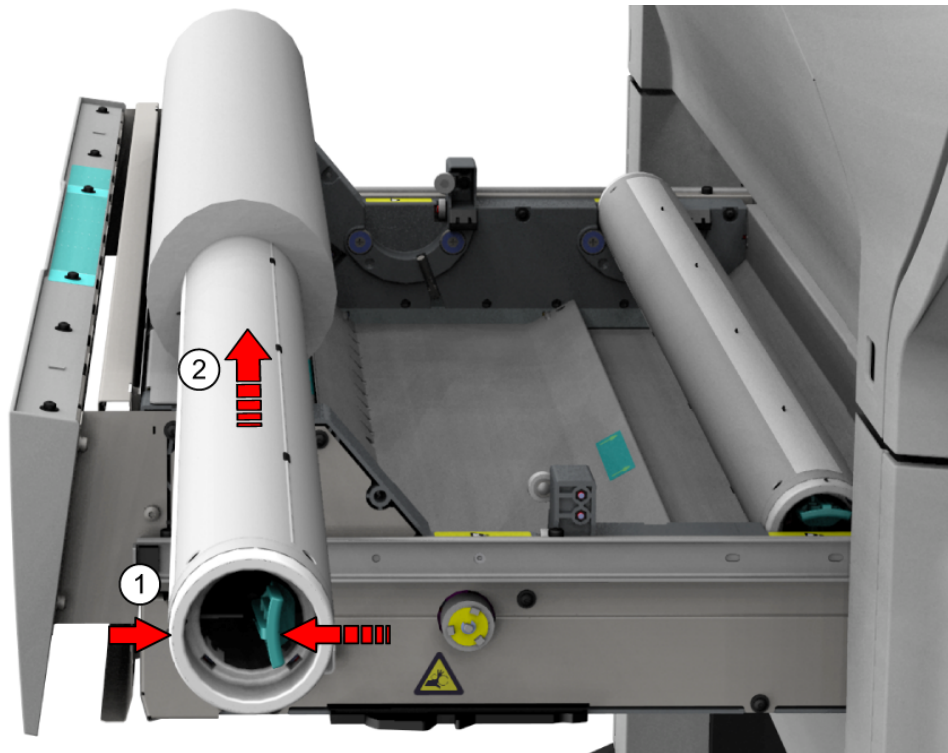

4. Align the roll with the **center of the correct size indicator** on the roll holder and release the handle of the locking mechanism.



5. Remove the tapes from the new media roll.
Use both hands (as indicated) to place the media roll in the media drawer.

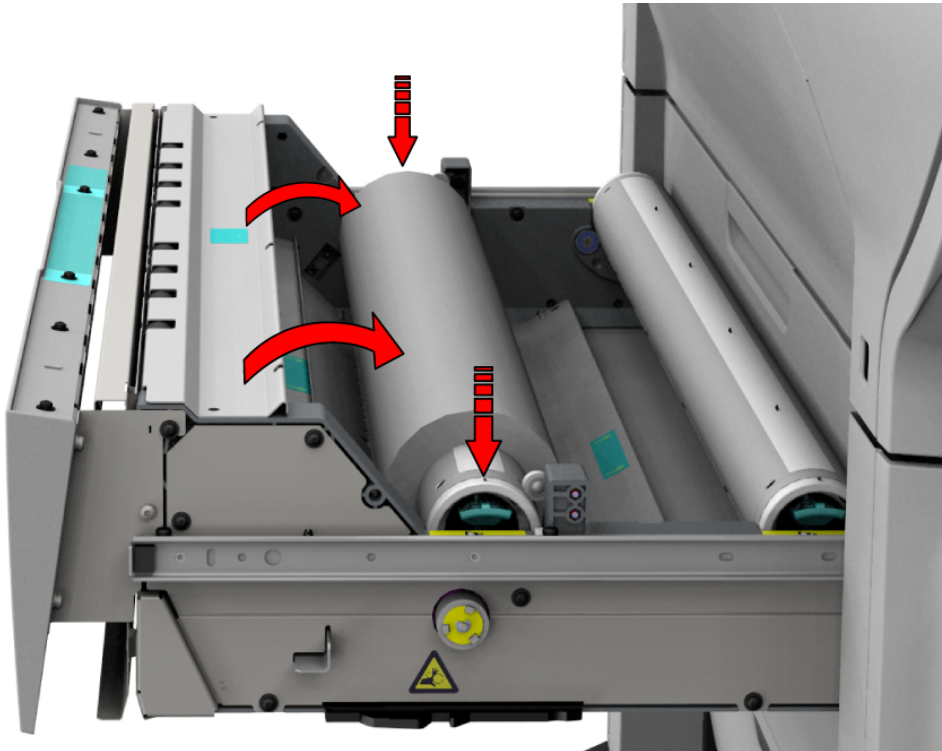

6. Use both hands to turn the media roll backwards (1) until the media flap has passed the metal paper guide.

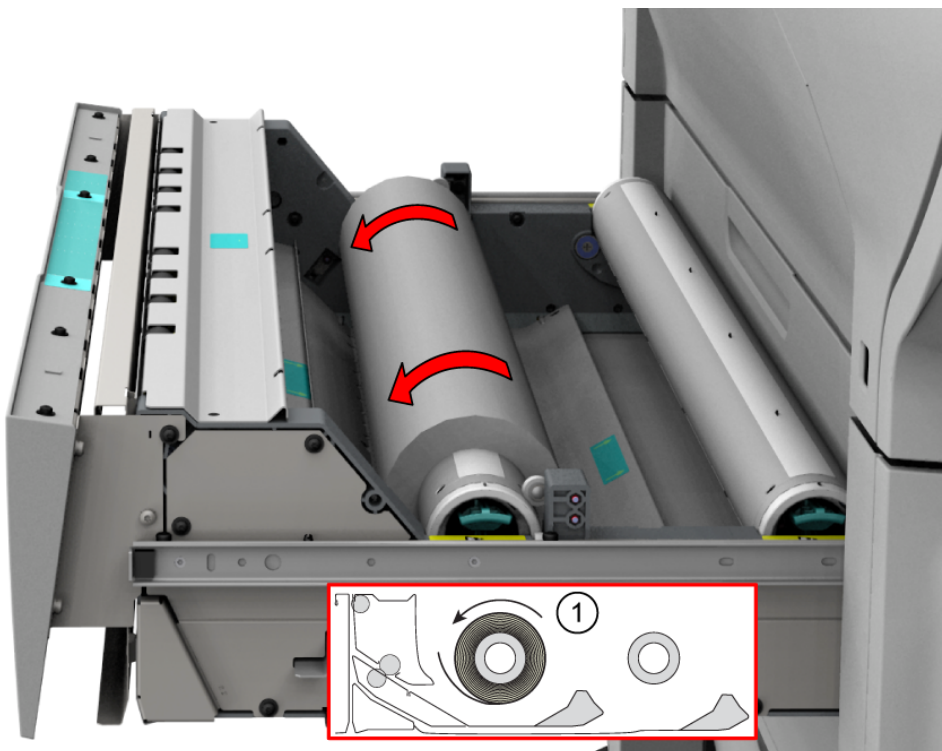

7. Use both hands to slide the media under the metal paper guide (2) until the media is transported automatically.

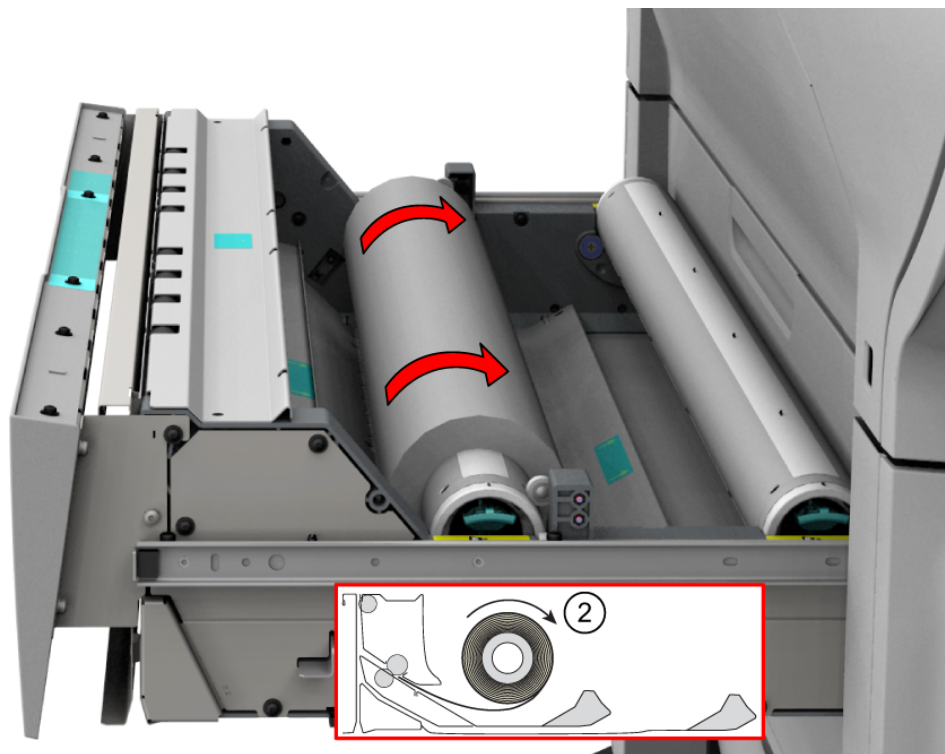

8. Close the media drawer. The user panel displays the message that new media is detected.



NOTE

Do not open the media drawer during loading.

9. Follow the steps in the wizard to define the correct media. Select the media type. The printer detects the correct size automatically. Choose whether you want a short, long, or no strip, and tap [OK].



NOTE

For the highest output quality, it is advised to always perform a media calibration when you load a new media type.

Result

You can now print on the newly loaded media.

Media types

Introduction

Canon machines and media are matched for the best quality and performance.

The table below gives an overview of applications and the typically used media types. The local assortment can vary, depending on preferences and availability. Media names can also be different. Ask your local representative for a complete media list.

You can select the media names on:

- the multi-touch user panel
- WebTools Express
- Driver Select for Microsoft® Windows®
- Driver Express for Adobe® Postscript® 3™
- Publisher Select

Media types and application



IMPORTANT

Do not store paper in rooms where temperature and humidity are high. In a recommended environment, with best print quality, temperature is not higher than 27 degrees Celsius or 80 degrees Fahrenheit and relative humidity is between 30 to 60 percent. Avoid dust and direct sunlight. Wrap unused paper in plastic to prevent it from absorbing moisture.

Application	Typical media types
CAD	Uncoated Tyvek 75 g/m ² Polyester film Vellum
Map/GIS	Uncoated paper 60-110 g/m ² Uncoated Tyvek 75 g/m ²
Schematic	Uncoated paper 75-120 g/m ²
Disposable POP	Uncoated paper 60-160 g/m ² Self-adhesive paper Blueback paper
Thematic POP	Self-adhesive paper 90 -120 g/m ² Uncoated paper < 200 g/m ² Uncoated Tyvek 75 g/m ²
Poster	Uncoated paper 60-160 g/m ² Blueback paper 120 g/m ²
Indoor banner	Polypropylene film 150-200 µm Polypropylene film 150-200 µm Light-block film
Event banner	Uncoated Tyvek 75 g/m ²
Street furniture	Blueback paper 120 g/m ²
Economy backlit	Backlit paper 100-120 g/m ² Translucent film 100-150 µm
Fine art	Embossed canvas-like paper Soft banner

Media types

Application	Typical media types
Photo print	Instant-dry photo paper 120-190 g/m ²
Special applications, customized CrystalPoint applications	For example: Temporary table linen

Media sizes

Introduction

Canon machines and media are matched for the best quality and performance.

The table below gives an overview of all the selectable media sizes. When your media size is not part of the list, you can create your own custom media sizes. For more information see, [Create a custom media size on page 182](#).



IMPORTANT

Do not store paper in rooms where temperature and humidity are high. In a recommended environment, with best print quality, temperature is not higher than 27 degrees Celsius or 80 degrees Fahrenheit and relative humidity is between 30 to 60 percent. Avoid dust and direct sunlight. Wrap unused paper in plastic to prevent it from absorbing moisture.

Media sizes

ISO A (DIN) range

Media	Width [mm]	Length [mm]
A3	297	420
A2	420	594
A1	594	841
A0	841	1189

ISO SRA range

Media	Width [mm]	Length [mm]
SRA3	320	450
SRA2	450	640
SRA1	640	900
SRA0	900	1280

ISO B (DIN) range

Media	Width [mm]	Length [mm]
B3	353	500
B2	500	707
B1	707	1000
B0	1000	1414

Carto B range

Media	Width [mm]	Length [mm]
CartoB3	350	500
CartoB2	500	700
CartoB1	700	1000

Media	Width [mm]	Length [mm]
CartoB0	1000	1400

ANSI range

Media	Width [inch]	Length [inch]
B	11 / B	17
C	17	22
D	22	34
E	34	44

ARCH range

Media	Width [inch]	Length [inch]
B+	12	18
C+	18	24
D+	24	36
E+	36	44

ARCH1 range

Media	Width [inch]	Length [inch]
15inch	15	21
21inch	21	30
E1 (30 inch)	30	42
42inch	42	60

Other

Media	Width [mm]	Length [mm]
310 mm (x340 mm)	310	340
330 mm (x450 mm)	330	450
440 mm (x594 mm)	440	594
440 mm (x620 mm)	440	620
450 mm (x625 mm)	450	625
620 mm (x880 mm)	620	880
660 mm (x841 mm)	660	841
800 mm (x1189 mm)	800	1189
800 mm (x1200 mm)	800	1200
880 mm (x1230 mm)	880	1230
891 mm (x1260 mm)	891	1260

Refill the toner

Replace the toner cartridge

Introduction

With the closed off toner cartridges, you can easily refill toner.

When to do

When a 'Toner Low' message appears on the user panel, you need to refill the toner. The message will be displayed until you refill the toner. Under normal conditions the printer can finish the current job, before it stops printing.



Before you begin

- You cannot add toner while printing. Wait till the printer stops printing or abort the job.
- You can leave the printer turned on when you refill the toner.
- Make sure you use toner suitable for the ColorWave 3600.
- When the printer is in Roll-to-roll mode, you have to cut the media before you can replace a toner cartridge.

Procedure

1. Unpack the toner cartridge.



NOTE

Do not throw away the packaging of the new toner cartridge. The packaging is used as maintenance tray.

2. Remove the red transport clip from the toner cassette.

3. Remove the empty toner cartridge from the printer.



4. Place the new toner cartridge.

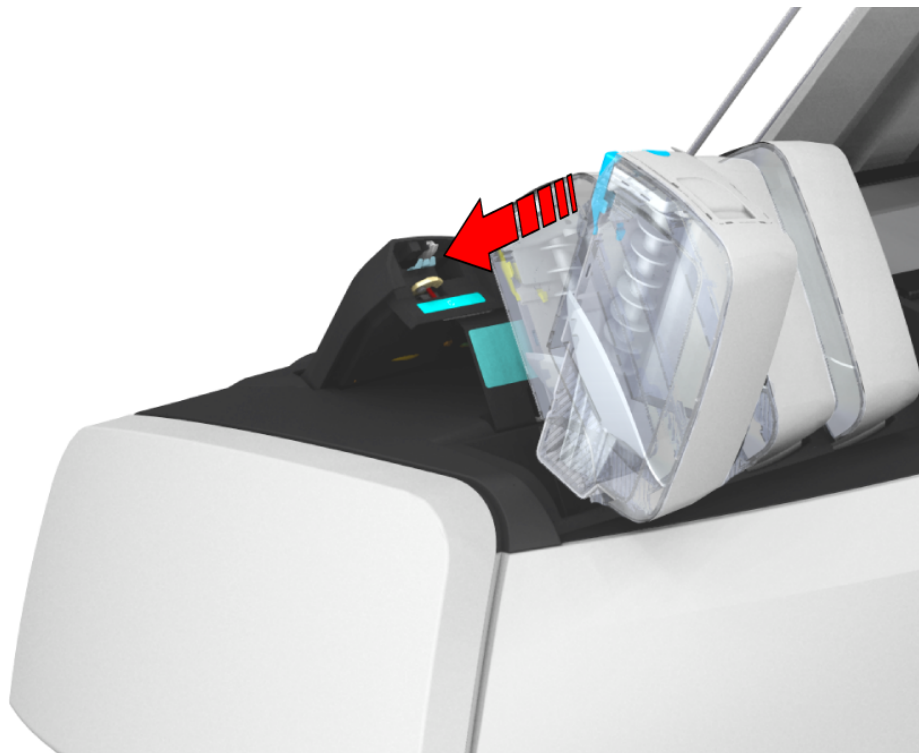

5. Place the toner cartridge in the correct color position.
[1] cyan, [2] yellow, [3] black, [4] magenta.



6. When the new toner cartridge is placed correctly, a wizard for the maintenance tray appears on the user panel. Follow the instructions on the wizard. For more information, see [Replace the maintenance tray on page 290](#).

Replace the maintenance tray

Introduction

Replace the maintenance tray when the user panel displays the message with a request. The maintenance tray is the packaging of the toner cartridge. For more information, see [Replace the toner cartridge on page 287](#).



No	Component	Description
1	[Maintenance tray drawer]	The maintenance tray drawer is located at the back side of the printer. When the printer starts up, some toner is needed for the imaging devices to optimize print quality. This is done with a so-called pressure pulse wipe sequence. The toner that is used to reach 'ready to print' is collected in the maintenance tray. During the day this process is repeated a few times to keep the imaging devices in the best condition.

Replace the maintenance tray

Procedure

1. The user panel displays a message when you have to replace the maintenance tray. Follow the instructions in the wizard.

2. Push the maintenance tray drawer to unlock it.

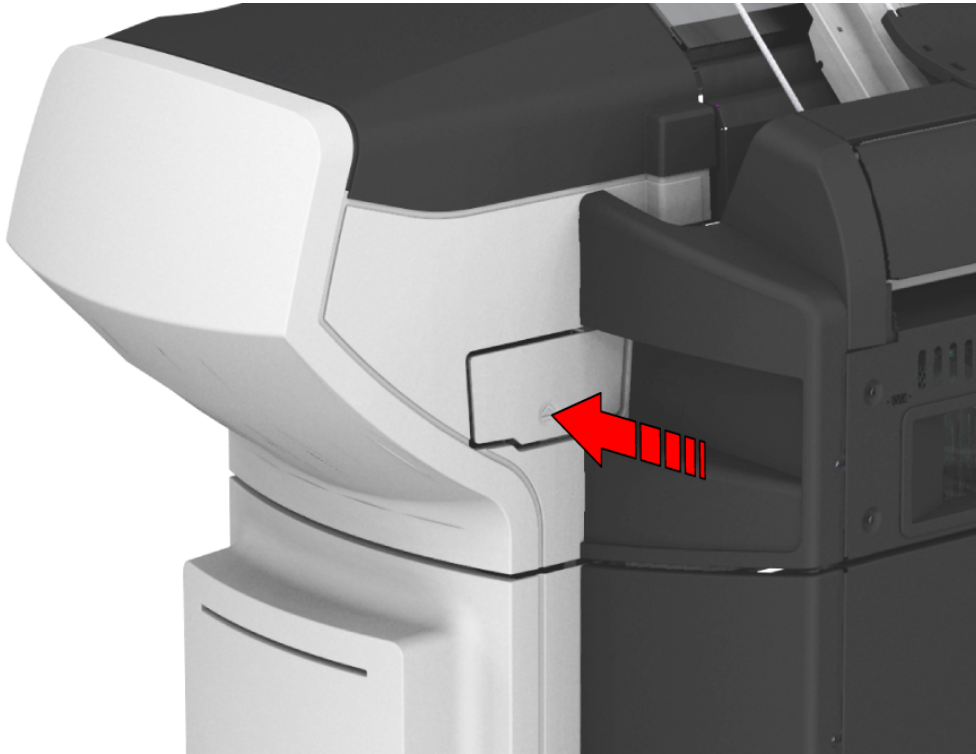

3. Open the drawer.



4. Remove the old maintenance tray.

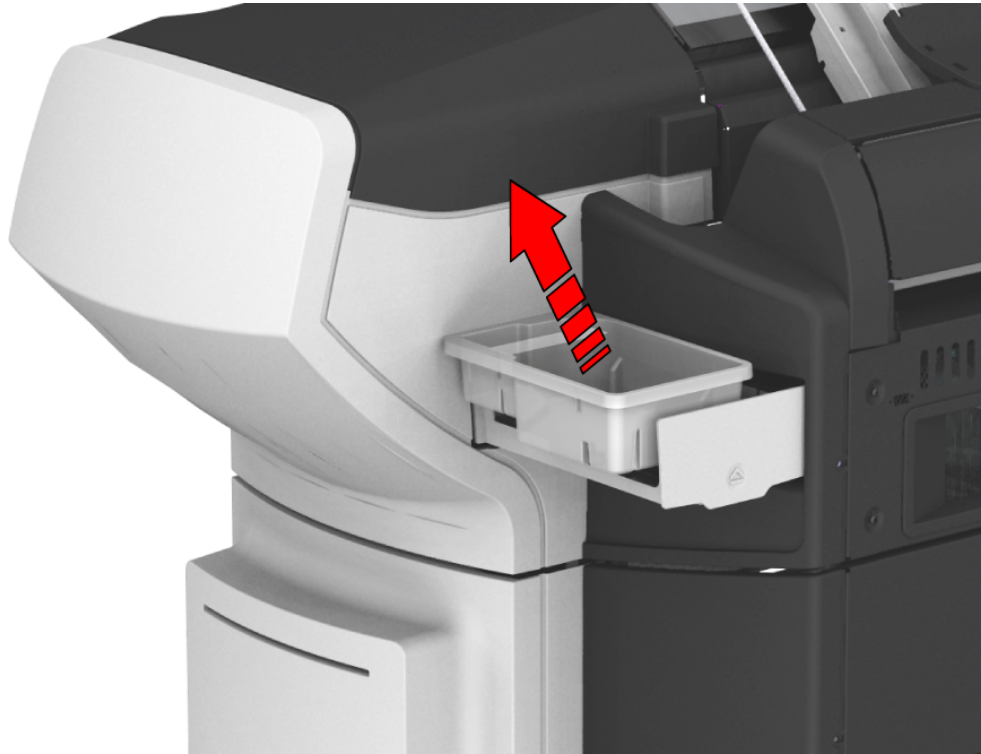

5. Place the new maintenance tray.

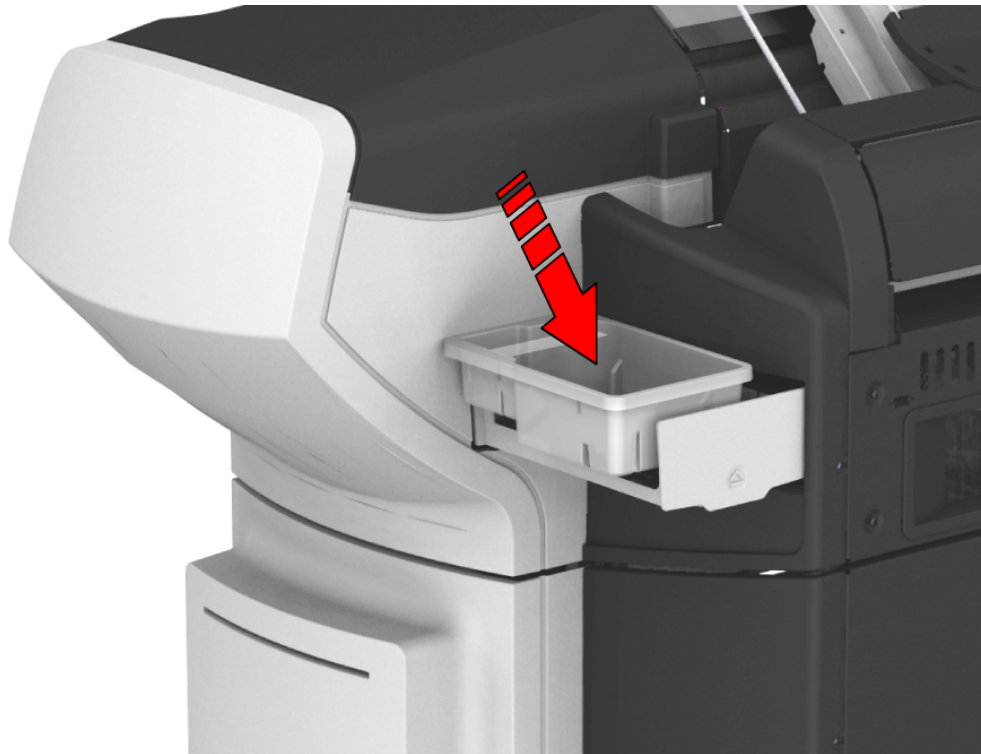

6. Push the drawer shut.



7. When the new maintenance tray is placed correctly, tap [OK] in the wizard. The old maintenance tray can be disposed of in regular office waste.

Maintain the scanner

Clean the scanner

Introduction

Clean the scanner from time to time, to prevent decrease of copy and scan quality.

When to do

Clean when:

- the transparent contact plates are dirty and static
- the original support rollers are dirty, and you use transparent originals

Procedure

1. Use both hands to push up the left and right scanner open levers to fully open the scanner top cover.
A locking mechanism prevents the scanner top cover from closing.

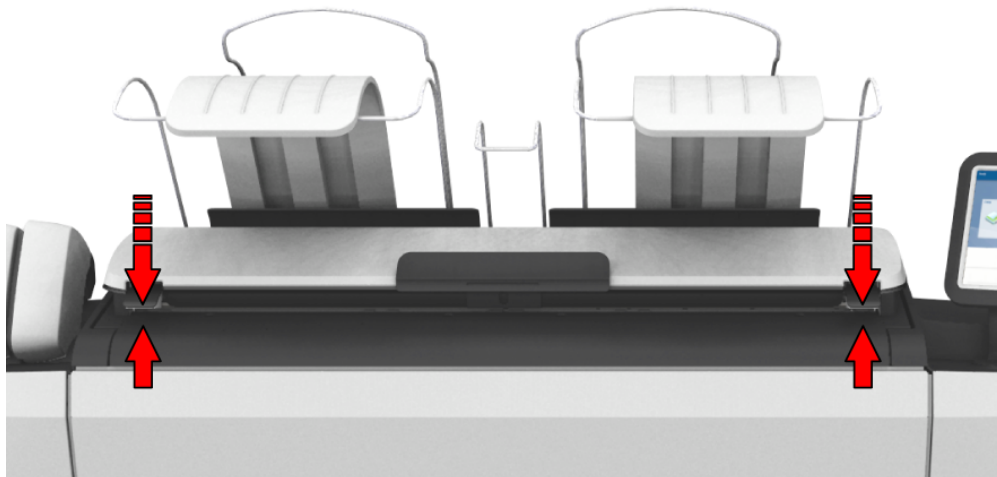

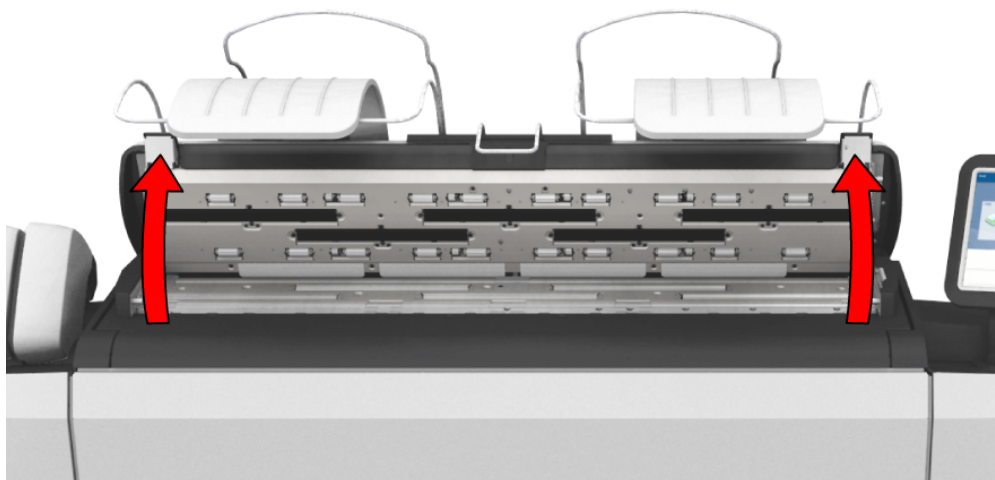
**IMPORTANT**

To clean the scanner, use the soft lint-free muslin towels from the scanner cleaning kit.

2. Use a muslin towel that has been moistened with water and firmly wrung out to clean the following parts of the scanner:
 - The original support rollers.
Rotate the rollers to clean them.
 - The transparent contact plates.
Wipe off any soiled areas.

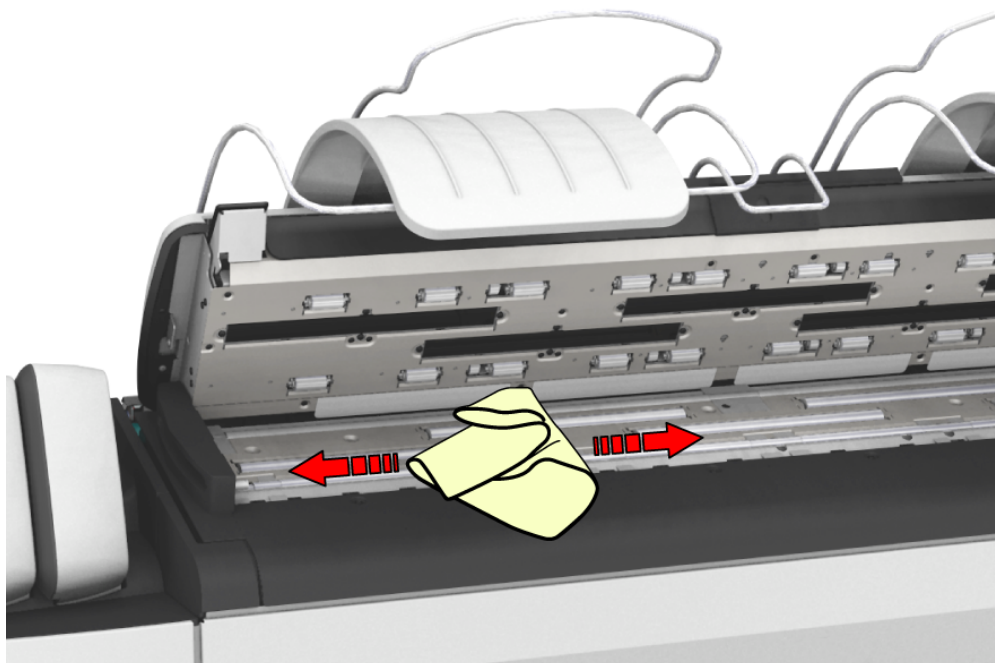

3. Wipe all the cleaned parts once again using a dry muslin towel.



CAUTION

Watch out, not to get your fingers caught in the scanner top cover.

4. Press the scanner top cover down gently with both hands, to close it.



NOTE

Check that the left and right scanner open levers are locked into position.

Calibrate the scanner

Introduction

You can calibrate the scanner when you are not satisfied with the copy or scan quality. Use the calibration wizard to calibrate the scanner.

Before you begin

Clean the scanner before you start the calibration procedure. Dirty parts of the scanner cause copy and scan quality to decrease. For more information, see [Clean the scanner on page 294](#).



IMPORTANT

- Handle the calibration sheet with care.
- Do not touch the black area of the calibration sheet with your fingers.
- Before you use the calibration sheet, wipe off any dust from the calibration sheet.

Procedure

1. Tap on the system menu thumbnail. The system menu opens.
2. Tap on [Scanner calibration] in the list in the right part of the display.
3. Log in as a Key operator or Power user. A wizard opens up.
4. Follow the instructions in the wizard.
5. Insert the scanner calibration sheet when instructed in the wizard.
6. Tap the green button to start the scanner calibration.



NOTE

[Calibrating the scanner takes between 5 to 10 minutes.]

Chapter 6

License management

Introduction to license management

Introduction

For certain applications your printer uses, you need to activate a license. A product license for the ColorWave 3600 is always required. You can perform several actions for licenses:

Procedure

1. View the currently active licenses.
View which licenses you already have, and which you would like to have. You can make a list of new options you need and note down the license number. Your local representative needs the list of new options and the license number to create a new license file.
2. Get the host ID of your system.
The host id is needed to create a new license file.
3. Send the list of new options, the license number, and the host ID to your local representative.
Your local representative creates and delivers a new license file.
4. Create a back-up of the currently active licenses, if necessary.
Save the current active licenses to do so.
5. Activate the licenses.
The license activation job guides you through the following steps.
 - 1. Locate the license file.
 - 2. Preview the new active licenses.
 - 3. Accept the end user license agreement.
 - 4. Finish the license activation job.
 - 5. Restart your system.

Check your licenses

About the licenses

The license section in WebTools Express allows you to manage the licenses that are active on your system. A license is needed to activate certain functions on your printer.

License information overview

Open the [Support] - [Licenses] tab in WebTools Express to view the available licenses.

You can view the license information for the following purposes:

- Check the license state, license type and license duration of active licenses.
- Check how long a license is valid.
- View all options available for your system.
- Make a list of the new options you need.
- Make a list of license numbers.

Information	Description
[Option]	This field displays the name of the option.
[State]	This field displays one of the following license states. <ul style="list-style-type: none">• [Authorized]. You are authorized to use the function.• [Not authorized]. You are not authorized to use the function, you need to get a license for the function.
[License type]	This field displays one of the following license types. <ul style="list-style-type: none">• [Resale].• Not for resale.
[Duration in days]	This field displays the time your license is valid.
[License number]	This field displays the license number.

Save the currently active licenses

Introduction

You can save all active licenses into one single file.

When to do

Save the currently active licenses before starting a license activation job or if you want to save the current license situation.

Procedure

1. Open the [Support] - [Licenses] tab.
2. Click on the [Save] button.
A zip file is being downloaded.
3. Select a directory on your workstation to store the zip file.
4. Enter the new file name and click on [Save] to back-up the currently active licenses.

Get a new license file

Introduction

The Canon applications and optional functions are protected against unauthorized use. You need to activate licenses to enable various options. When you want to get a new license you have to provide the correct information to your local representative.

Procedure

1. Open the [Support] - [Licenses] tab to display the license information page.
2. View which licenses you have and do not have. Note the [Option] information and the license number down of the licenses you would like to have.
3. Click on [Host id], and note the host id information down.
4. Send the license information and the host id to your local representative.
5. After receiving the license file from the representative, store the file on the network.

Result

After you stored the new license file, you can activate the license. For more information, see [Activate a new license on page 304](#) .

Activate a new license

Introduction

Under the [Licenses] tab in WebTools Express you can activate new license files.



NOTE

- It is advised to store the license information of the currently active license files in a back-up file before you activate a new license file. Use the [Save] button to store the current license files information.
- After the license is uploaded you must restart your system to activate the license file.

Procedure

1. Open the [Support] - [Licenses] tab to display the license information page.
2. Click [Activate] to open a browser window to search for the license file on the network.
3. Browse the network and select the license file.
4. Click [Next], read the step and click [Next] again.
5. When the user agreement appears, scroll down to the bottom and check the box in front of [I agree].



NOTE

If you do not check the box for agreement, your license will not be installed.

6. Click [Next].
7. Click [OK] to start the activation of the license file. A message appears when the process is completed.
8. Restart the system to activate the changes.

Result

- If you update an expired license, the new license file overwrites the previous license file.
- If you upload a new license, the license state in the overview is changed from [Not authorized] to [Authorized].

Chapter 7

Account management

Introduction to account management

The printing system supports account management. This can be enabled and disabled in WebTools Express. When enabled the user has to provide accounting information for print, scan and/or copy jobs. It is possible to enable this separately for print jobs, or for scan and copy jobs.

Which accounting information needs to be provided is determined by the customer via Océ Account Console, Repro Desk or a third party application like uniFLOW.

This chapter contains an introduction to Océ Account Console. For information about Account Management with another application, see the documentation of that application.

Enable account management in WebTools Express

Introduction

To enable account management you can define the values in WebTools Express

Definition

The account information requirements are defined and managed by the administrator.

How to define the 'Logging and accounting' settings

Open the [Preferences] - [System defaults] tab, and under [Job management] enable the [Force entry of accounting data for print jobs] or [Force entry of accounting data for copy and scan jobs]. Then define the settings for accounting under [Accounting log].

Setting	Value	Description
[Force entry of accounting data for print jobs] [Force entry of accounting data for copy and scan jobs]	[Yes]	When [Yes], it will only be possible to print jobs or create copy and scan jobs that have valid accounting data. All print jobs will be forced to go to the Smart Inbox. If you use Publisher Express to send your print job, you must enter the required accounting data in the "Create new job" window. When you want to copy or scan from the user panel, or print a job from a USB key, you must enter the required accounting data on the user panel. The accounting data fields are displayed on the user panel.
	[No]	No accounting data is required.
[Log file format]	[ASCII (7-bits)] [Unicode (UTF-16)]	Define the file format for the export file of the account logging data. This file is retrieved by the Océ Account Console application for account management.
[Log data field separator]	[Comma] [Semicolon] [Tab]	Define the field separator that must be used in the log file.
[Number of days to keep log files]	numeric value	Enter a value between 1 and 99 days.
[Accounting dialog upload: host]	[From any host] [From single host]	Defines if an accounting dialog upload is accepted from any host or from a single host only.
[Accounting dialog upload: single host]	hostname	The hostname or IP address from which an accounting dialog can be uploaded. Only valid when [Accounting dialog upload: host] has value [From single host].

Accounting data missing

If the required accounting data is missing, the  icon is displayed in front of the job in the Smart Inbox. To enter the missing accounting data, select the job and click [Edit].

An overview of Océ Account Center

Introduction

Use Océ Account Center to manage the account information of print jobs, copy jobs, and scan jobs for your devices.



NOTE

For this application a separate user guide and a Readme are available. Visit "<http://downloads.cpp.canon>", select your printer and find your document in the list.

Definition

Océ Account Center includes software module:

- Océ Account Console.

Océ Account Console runs on a PC that functions as a server. Access to the Océ Account Console application is password protected and limited to authorized personnel.

The administrator uses Océ Account Console to create the account information dialog. The administrator publishes the account information dialog for WebTools Express, the user panel and other applications.

The bookkeeper uses Océ Account Console to retrieve and export the log data.

The bookkeeper uses the log data for accounting purposes.

User roles and tasks in Océ Account Center

Users	Tasks
1) Administrator	<ul style="list-style-type: none">• Create, manage and delete the account dialog.• Publish the account dialog to WebTools Express and the user panel.
2) Users	<ul style="list-style-type: none">• Use the dialog of WebTools Express to enter the account information for print jobs, copy jobs and scan jobs.
3) Bookkeeper	<ul style="list-style-type: none">• Retrieve and use the account information of print jobs, copy jobs and scan jobs that is stored on the embedded controller of your device. The log data serves as input for the accounting reports and invoices.

Océ Account Console ®

Introduction to Océ Account Console

Definition

Océ Account Console is installed on the administrator's workstation.

Purpose

Océ Account Console has the following functionalities:

- Manage, preview, and publish the account information dialog.
- Retrieve and export the log files.
- Manage the devices.



NOTE

For this application a separate user manual is available.

Illustration

The screenshot displays the Océ Account Console interface. At the top, the title bar reads "Account Console" and "license administration" is visible on the right. Below the title bar, there are three tabs: "Dialog", "Devices", and "Export filters". The "Dialog" tab is active, and within it, the "Fields" sub-tab is selected. The "Fields" sub-tab shows a tree view with "User ID" selected, which is expanded to show "Project" and "Account ID". The "Values" sub-tab is also visible, showing a table of data. The table has three columns: "Name", "Id", and "Id". The data rows are: "Jeff" with "jdc", and "Arthur" with "agb". At the bottom left of the interface, it says "Last published: Wednesday, 27 Apr 2006 12:56:36 PM".

Name	Id	Id
Jeff	jdc	
Arthur	agb	

Summary of Océ Account Console

Main parts of Océ Account Console

An administrator uses Océ Account Console to perform a number of maintenance and configuration tasks.

The main functional areas of Océ Account Console are described in the table below.

Main parts of Océ Account Console

Part	Description
The [Dialog] tab	<p>[Fields] section.</p> <ul style="list-style-type: none"> • Create an accounting dialog. The accounting dialog consists of a number of accounting fields. • Save an accounting dialog. The accounting dialog is saved in .xml for reference, back-up or uploading. • Load an accounting dialog. An accounting dialog can be uploaded for use. • Delete an accounting dialog. Please note that this action cannot be reversed. • Edit an accounting dialog. You can change the type of accounting field. • Change the order of the accounting field in the list. • Make a preview of the accounting dialog to test the validity. • Publish the accounting dialog. Make the accounting dialog available to external applications and devices. <p>[Values] section.</p> <ul style="list-style-type: none"> • Create values for each accounting field. • Import values with a CSV file. • Add values for each accounting field. You add existing values to an accounting field. • Delete values for each accounting field. Please note that this action cannot be reversed. • Edit values for the selected accounting field • Move the selected value up or down in the list. • [Sort A..Z]. Use this option to organize the list in ascending order. • [Sort Z..A]. Use this option to organize the list in descending order.
The [Devices] tab	<p>[Devices] section.</p> <ul style="list-style-type: none"> • [Create...]. Use this option to create a new device. • [Delete]. Use this option to remove the device. The log data for the device is removed as well. Please note that this action cannot be reversed. • [Edit...]. Use this option to change the values for a device. • [Delete log data]. Use this option to remove log data of a device. <p>[Tasks] section.</p> <ul style="list-style-type: none"> • 'Compress database'. Use this option to clean up the database. • [Start]. Use this option to run an update dialog or to retrieve log data. • [Edit...]. Use this option to change the conditions for the update dialog and the log data retrieval.

Part	Description
The [Export filters] tab	<p>[Overview] section.</p> <ul style="list-style-type: none"> • [Create...]. Use this option to define a new filter. • [Delete]. Remove the export filter. • [Edit...]. Change the filter definition. • [Copy...]. Make a duplicate of the filter settings to create another export filter. • [Run...]. Select the required filter and start the export of the log data. <p>'Statistics' section.</p> <ul style="list-style-type: none"> • [Create...]. Create a statistic's summary (statistics export) of all the data in Océ Account Console. • [Delete]. Delete the statistics export. • [Edit...]. Select the field you want to create a statistics export of. • [Run...]. Start creating the statistics export.
The [Licenses] screen	<p>The license screen enables you to perform the following actions.</p> <ul style="list-style-type: none"> • Determine the host ID necessary to receive a valid license file. • Select and activate the license file. • Create a back-up of the license file.
The [Administration] screen.	<p>The administrator screen enables you to perform the following actions.</p> <ul style="list-style-type: none"> • Change the password. • Publish the data that are retrieved from other applications. • Define the remaining settings for Océ Account Console. • Set the regional settings <ul style="list-style-type: none"> -Application language -Units of measure (points, metric values or imperial values) -Units of measure of the print area (points, metric values or imperial values).

Accounting workflow

Introduction

After the administrator configures the settings, accounting can be integrated in the workflow.

Procedure

1. Define an accounting dialog and publish it.
2. Add the ColorWave 3600 to the devices in Océ Account Console and configure the tasks.



NOTE

Configure the task 'Retrieve log data' to run every day at a time that the printer is switched on.

3. Run the task update dialog for the ColorWave 3600, to provide the dialog to the printer.
4. Enable accounting in WebTools Express.

Result

When you print via the driver, Publisher Express or Publisher Select you will have to provide accounting information before you can print.

When you copy, scan, or print from USB, you will have to provide accounting information on the user panel before you start your job.

Workflow on the printer

Procedure

1. Create a copy, scan or print job.
2. Press the green button, to start the job.
A dialog appears, asking the user to enter the required accounting information.
If the user does not enter the information, he cannot finish the job.

Chapter 8

Solve problems

How to solve problems with jobs

Procedure

1. When there is a problem with a job, the color of the green job queue bar in WebTools Express turns red.
The system monitor section of WebTools Express displays the message: [User intervention required].
The job that has the problem remains in the queue as an active job, displayed in bold fonts.
2. On the user panel detailed information about the problem is displayed. You can use this information to solve the problem.



NOTE

If a media jam occurs often, you can perform the following checks:

- Is the media loaded correctly?
- Did you use the correct media? For more information, see [Media types on page 283](#)
- Did you remove all the pieces of media from the paper path?



NOTE

If an error occurs that you cannot solve, please remember the error code displayed on the user panel and contact the helpdesk for assistance.

Clean the print surface

Introduction

It is necessary to clean the print surface regularly.

When to do

When a media jam occurs or when there is pollution on your printed output, it can help to clean the print surface.

Required tools

Use the supplied clean card. The clean card is located in the card holder under the [transparent top cover].

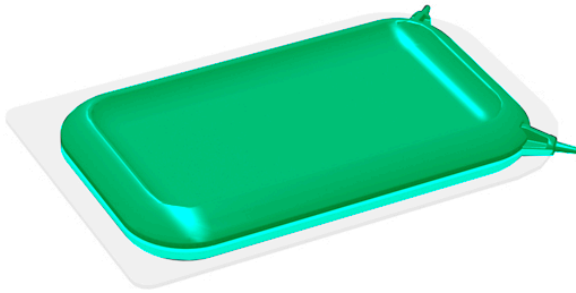

Procedure

1. Push the Top Delivery Tray towards the back and lock it into place.
2. Open the [transparent top cover].
You can now access the clean card and the print surface.



3. Check whether there are toner drops on the print surface.

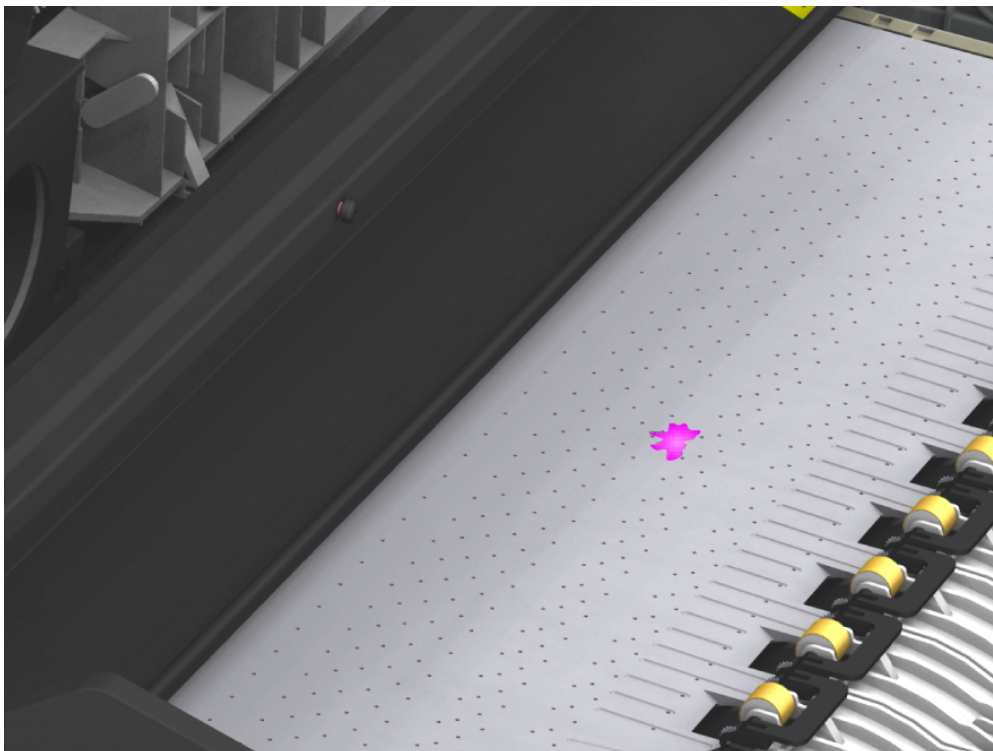

4. Remove the toner with the clean card.
Remove the pollution from the print surface by moving the card into the direction of the toner cartridges.

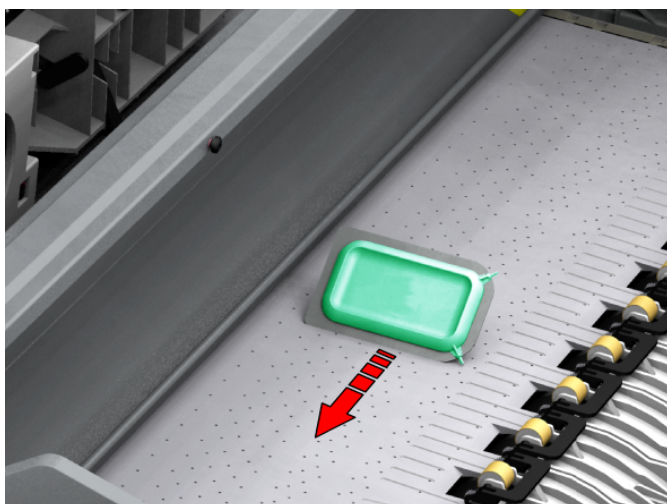

5. When the holes in the print surface are not open, use the pins on the clean card to open the holes.

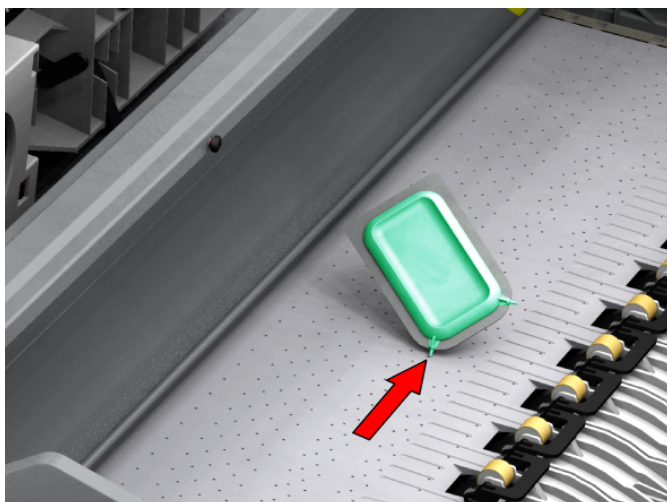

6. Place the clean card back in the card holder.

7. Close the [transparent top cover] and place the Top Delivery Tray back in its original position.

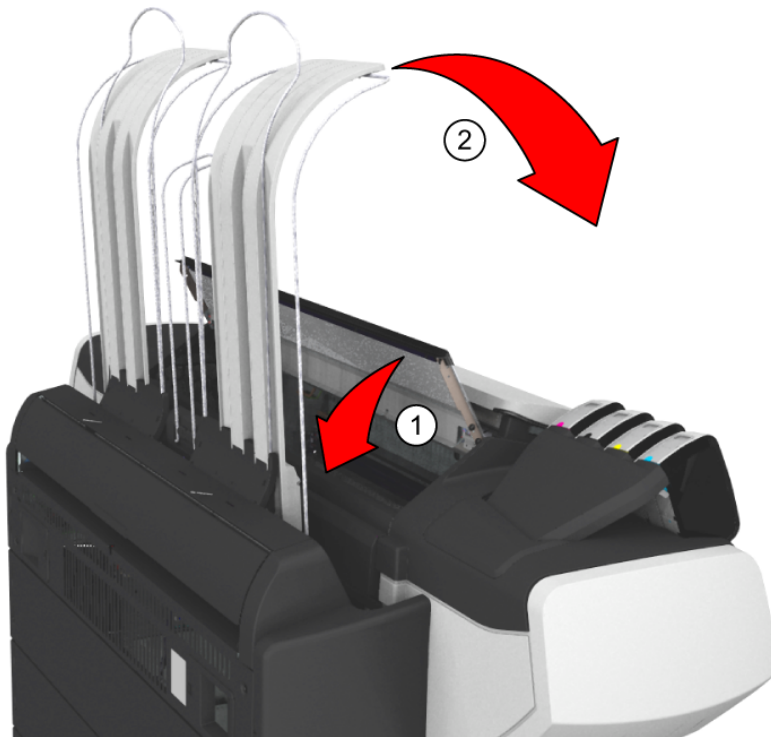

Clear an original jam in the scanner

Introduction

When an original jam occurs in the scanner, the message [Scanner original jam] appears on the user panel. You must remove the original from the scanner. Follow the steps in the wizard on the user panel to clear the jam.

If an original jam occurs often:

- Check whether you used the correct type of original.
- Check if the original is damaged before you insert it.

Procedure

1. Use both hands to push up the left and right scanner open levers to fully open the scanner top cover.
A locking mechanism prevents the scanner top cover from closing.

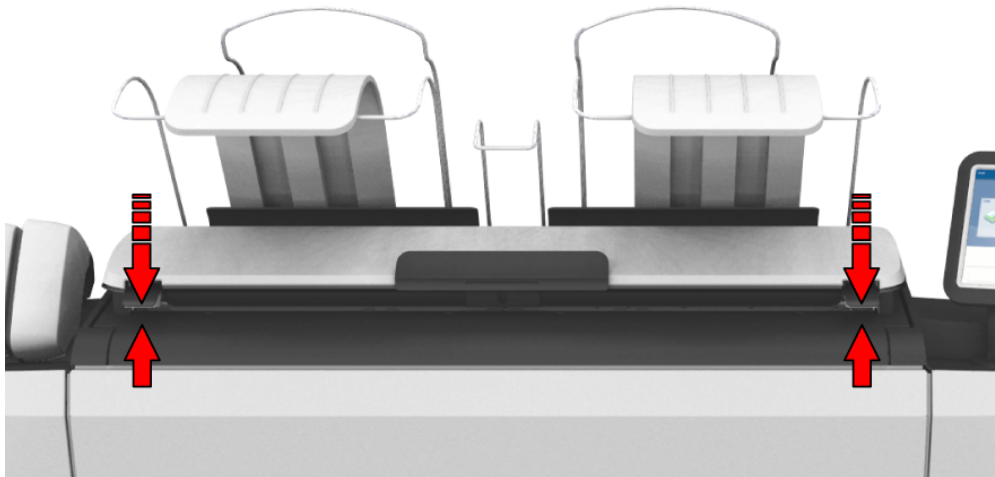

2. Remove the original.
Pull the original from the scanner, or from the originals exit at the front.
3. Press the scanner top cover down gently with both hands to close it.



NOTE

Check that the left and right scanner open levers are locked into position.

4. Smooth out the original, and feed the original.

Disconnect the network cable and the mains supply cable

Procedure



IMPORTANT

Make sure the main power switch (A) is in 'off' position.

1. Disconnect the network cable from the network connection at the right back of the printer (D).

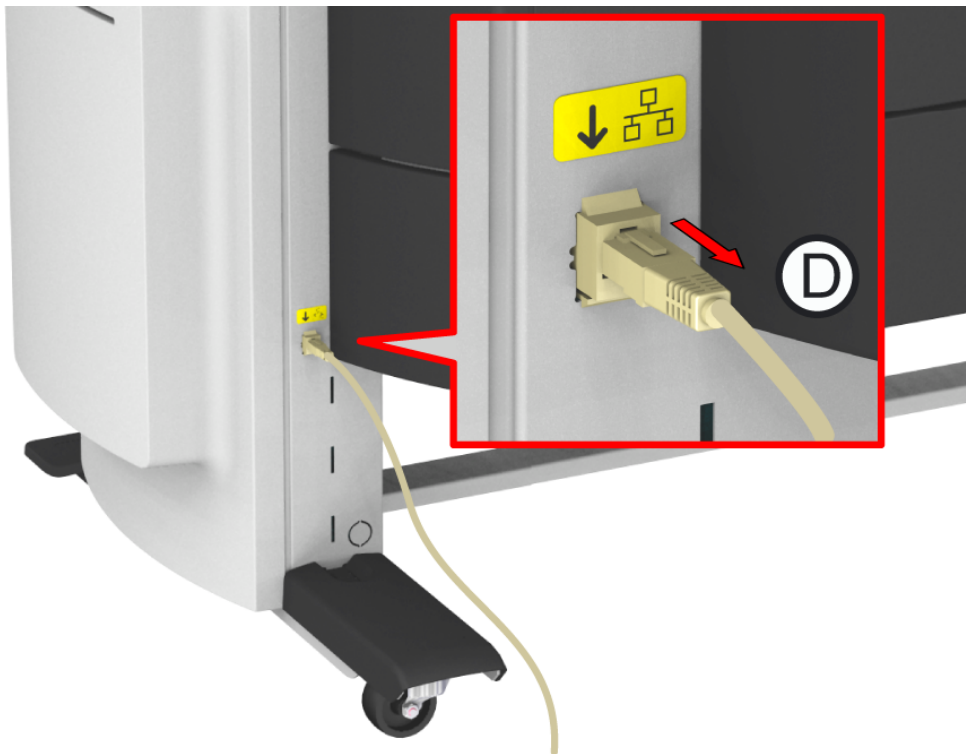

2. Disconnect the mains supply cable from the wall socket.
3. Lift the cover (B).

4. Disconnect the other side of the mains supply cable from the power connection at the right back of the printer (C).

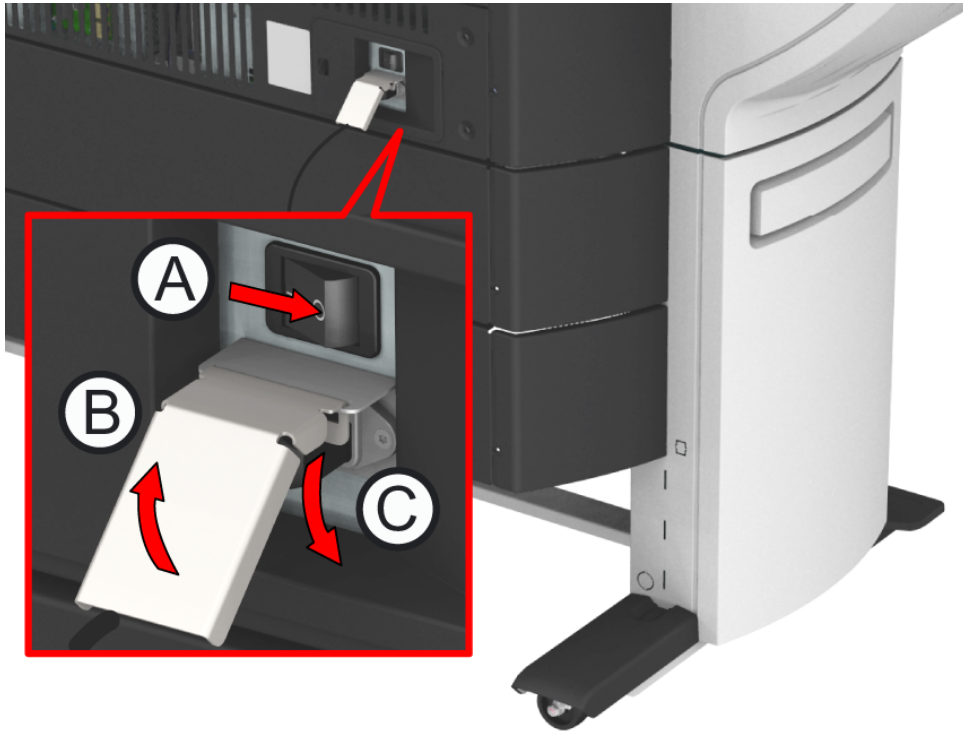

Event messages

Introduction

Feedback on errors related to print jobs is displayed in the event list.

You can open the event list when you click [View events] in the upper right hand corner of the Jobs tab in WebTools Express.

Procedure

Event message	Troubleshoot
[Partially printed job aborted due to reception problem (protocol error, connection failure, spool full)]	<ul style="list-style-type: none"> • Check the structure and keywords of the Job Ticket. • When the user panel displays the message [Job memory full], delete some jobs from the system. • Check if the printer can be reached on the network.
[Job aborted due to reception problem (protocol error, connection failure, spool full); nothing was printed]	<ul style="list-style-type: none"> • Check the structure and keywords of the Job Ticket. • When the user panel displays the message [Job memory full], delete some jobs from the system. • Check if the printer can be reached on the network.
[Document could not be printed; specific TIFF/CALS mode is not supported]	<p>The document type is not supported by the printer (for instance, CALS file of type 2).</p> <ul style="list-style-type: none"> • Generate a new file.
[Unable to process the print job (not enough memory or disk space).]	<p>The file is complex and the printer does not have enough memory to process it.</p> <ul style="list-style-type: none"> • Try to print it from an application using the Driver Select for Microsoft® Windows® . • If the error persists, contact your local Service representative.
[PS/PDF missing or invalid data in the document; one or more pages not correctly printed]	<p>The Postscript or PDF file is corrupt.</p> <ul style="list-style-type: none"> • Try to print the original file from Adobe Reader or directly from the application using the Driver Select for Microsoft® Windows® . • Try to generate the file again. • If the error persists, contact your local Service representative.
[PS/PDF limitation; one or more pages not correctly printed]	<p>The Postscript or PDF file causes an internal printer error.</p> <ul style="list-style-type: none"> • Try to print it from an application using the Driver Select for Microsoft® Windows® . • If the error persists, contact your local Service representative.
[PS/PDF resource issue (memory, disk); one or more pages not correctly printed]	<p>The Postscript or PDF file is complex and the printer does not have enough memory to process it.</p> <ul style="list-style-type: none"> • Try to print it from an application using the Driver Select for Microsoft® Windows® . • If the error persists, contact your local Service representative.

Event message	Troubleshoot
[PS/PDF resource or language problem; one or more pages not correctly printed]	<p>The Postscript or PDF file is complex or corrupt.</p> <ul style="list-style-type: none"> • Try to print it from an application using the Driver Select for Microsoft® Windows® . • If the error persists, contact your local Service representative.
[No pages were generated when processing the document]	<p>The file contains non printable pages.</p> <ul style="list-style-type: none"> • The graphic commands in the file could be missing, the file is corrupt. • The shift setting could be set to a value that causes the image to move completely off the paper.
[Job deleted because it is not recoverable (data is corrupt or incomplete)]	<p>This message can appear when the printer is restarted after a power failure and some documents in the printer spool are corrupt.</p> <ul style="list-style-type: none"> • Reprint the job from the submission application or from the Smart Inbox.
[Job deleted because it causes a software crash in the printer]	<p>This message can appear when the printer is restarted after a power failure and some documents in the printer spool cause software problems.</p> <ul style="list-style-type: none"> • Generate the file again. • If the error persists, contact your local Service representative.
[Job was deleted from the queue after a media request time-out]	<p>The job has been deleted from the print queue because the time-out of the media request expired and the [Action after media request timeout] is set to [Delete the job]</p> <ul style="list-style-type: none"> • Reprint the job from the submission application or from the Smart Inbox.
[Job cannot be printed because the required PS/PDF license is not available]	<ul style="list-style-type: none"> • For Postscript and PDF files, check if the license is installed.
[Job cannot be printed because the required PDL is disabled]	<ul style="list-style-type: none"> • Click [Configuration] - [Printer setup] and change the printing of this page description language to [Enabled].
[Folding is disabled: the legend is not detected or the rotated document does not fit on the available media.]	<p>The [Finishing Assistant] disabled folding. This can happen if the image cannot be rotated so that the legend is visible after folding and fit on the available media. This may also happen if the [Finishing Assistant] cannot detect the location of the legend.</p> <ul style="list-style-type: none"> • You can fold manually. • Disable [Finishing Assistant] if you do not care where your legend is after folding or if you want to fold a drawing without a legend. • Load a larger media size if the rotated drawing fits into the maximum foldable media width (check the finisher specifications).
[Folding is disabled: the folding device cannot fold the printed output (incompatible size or media type).]	<ul style="list-style-type: none"> • Folding has been disabled because the media size or type is incompatible with the folder. Use correct media that can be folded.

Event message	Troubleshoot
[The sheet length exceeds the limit of the second fold. Only the first fold applied.]	<ul style="list-style-type: none"> • The document will be first folded only. • Check the maximum length settings for second fold and comply, when you want to get a fanfold package.
[Document is not a PDL or the PDL is not supported]	<p>Check if the printer recognizes the format of the sent job.</p> <ul style="list-style-type: none"> • Submit the file via the job submitter. • Print directly from the application.
[The scan job cannot be delivered to the external location. The job has been deleted.]	<ul style="list-style-type: none"> • Check the credentials, the username and password, of the external location. • Use the check feature in the external location configuration window. • Check all other external location settings.
[Impossible to generate the file from the scanned original(s). Try to scan again with a lower output file resolution. If the error persists, make sure the original is not too long.]	<ul style="list-style-type: none"> • Lower the output file resolution. • Change the file type. • Reduce the original size when it is too long. • Check the scan resolution and the compression. • In case of a multi-page document: split it into several scanned files.
[The accounting data for the job are invalid. The job has not been printed.]	<ul style="list-style-type: none"> • Correct the accounting data in the submission application and reprint the job from the smart inbox. • Check whether the accounting parameters are correctly synchronized, on the job submission tool or driver.
[Print settings conflict: the document is identified and printed with the settings embedded in the file]	<p>A job was submitted from an application that added a Job Ticket while the file already contained a Job Ticket. The settings you have selected in the submission application are not used. Instead, the Job Ticket settings embedded in the file are used for printing and identification of the job. The job will appear in the print queue and the Smart Inbox with its original name.</p> <ul style="list-style-type: none"> • If the settings embedded in the file contain a Smart Inbox name, the job will be kept in that Smart Inbox. • If the settings embedded in the file do not contain a Smart Inbox name, the job will be kept in the default Smart Inbox defined in [System defaults] - [Job management]. • If you do not want to use the original settings embedded in the file, use Publisher Select to print the job.



Settings in case of errors

Introduction

If you encounter problems with print jobs, there are a few settings that can help you.

Procedure

1. Open the [Preferences] - [System defaults] tab.
2. Under [In case of errors], you can make the following settings:

Setting	Value	Description
[Clear system at next start-up]	[Yes]	Activate this setting when the printer has a problem with processing jobs in the queue. Restart the system to automatically remove all jobs from the system. Then deactivate this setting and restart the system again.
[Save received job data for Service]	[Yes]	When enabled, the system stores the job data of all received jobs. You can download the data under [Support] - [Maintenance], click on [Download the job data]. Service can access the job data when you encounter problems or for maintenance.  NOTE <ul style="list-style-type: none"> • Only enable this settings when you have problems with certain jobs. • Disable the setting after service to prevent performance reduction.
[Display a job event notification in WebTools Express]	[Yes]	When enabled, the system displays print job related attention messages in the queue view of WebTools Express.  NOTE <p>When you click on an attention message, the message is removed from the queue view of the web browser you use. In other web browsers the attention message remains visible until a user clicks on it.</p>

3. When you have made your settings, click OK.

Print a demo print

When to do

You can print a demo print to check whether the printer is working correctly.

Procedure

1. Tap the system menu thumbnail on the user panel. A window opens.
2. In the list on the right, select [Test prints]. A wizard opens.
3. Select [Demo print].
4. Tap OK.

Print a test print

When to do

Print a test print from a specific roll at the request of the helpdesk. The test print provides information that can help to solve quality problems.

Procedure

1. Tap the system menu thumbnail on the user panel. A window opens.
2. In the list on the right, select [Test prints]. A wizard opens.
3. Select the roll you want to print from.
4. Tap OK.

Chapter 9

Support

Counter history

Introduction

Navigate to the [Support] - [Counter history] tab to get an overview of the consumables used per printed job.

The table below gives an overview of the various functionalities you can access in the counter history to sort, group, save, or print the information you need.

Procedure

Functionality	Description
[Counter history]	In the header of the counter history list you can select the period (day(s) or week(s)) in a drop down list. The counter history list will display information about the jobs printed in the selected period.
Sort on [Job name], [Job owner], [Smart Inbox], or [Time printed]	When you want to sort the counter history list, you can click on the column headers of the counter history list: [Job name]; [Job owner]; [Smart Inbox]; [Time printed]. This way you can sort the list according to your needs.
[List view] or [Group view] .	Select [List view] at the bottom of the counter history list when you want to display all printed jobs. Select [Group view] at the bottom of the counter history list when you want to display only the groups based on your sort criterion. For example, if you sort your counter history list by the column [Job owner] and you click on [Group view], the counter history list displays a list with all job owners that have sent print jobs to the printer in the selected period. When you expand the [Job owner] group, the list displays all jobs that were sent by the [Job owner] in the selected period.
[View total info]	Select [View total info] in the upper right hand corner of the counter history list, when you want to have a complete overview with job counter information. Click on a group name to display counter information for all the jobs in the group. Click on a job name to display counter information for the selected job.
[Save all]	Select [Save all] in the upper right hand corner of the counter history list, when you want to save the counter history for all jobs in the list. You can save the counter data as an [XML file] or as a [CSV file].
[Print all]	Select [Print all] in the upper right hand corner of the counter history list, when you want to print the counter history for all jobs in the list.

Audit log

Definition

As a System Administrator, you can download a comma-separated values (CSV) file containing the audit of all security-related events in the system.

[Download audit events] and [Clear audit events]

Log in as a System Administrator and select the [Audit log] in the [Security] tab.

Click on the [Download audit events] button to download a comma-separated values (CSV) file containing the audit events.

Click the [Clear audit events] to clear the list of events stored in the system.

Remote Service: configure the proxy

Introduction

WebTools Express offers remote services from the printer to the service organization, or from the service organization to the printer.

You can edit these settings under the [Support] - [Remote Service] tab.

Remote Service has the following options:

- [Configure proxy]: Configure a secure Internet connection via a proxy server between the printer and the service organization.
- [Check connection]: Check the connection between the printer and the service organization.
- [Allow remote assistance]: Allow a remote assistance from the service organization to the printer.

Configure the proxy

Procedure

1. Open the [Support] - [Remote Service] tab, and click on [Configure proxy]
2. Set up the "Proxy server":
 - Automatic proxy detection: select this setting when you do not know all the proxy settings. You can select this setting to let the system detect the proxy automatically.
 - [Proxy enabled]: select this setting when you know the proxy settings and want to enable the proxy yourself. You have to fill in [Proxy hostname] and [Proxy port].
 - [Proxy hostname]: enter the fully qualified hostname of the proxy server.
 - [Proxy port]: enter the port of the proxy.
3. Set up authentication:
 - [Proxy requires authentication]: select this setting when authentication is required.
 - [Proxy authentication: user]: enter the user name for authentication.
 - [Proxy authentication: password]: enter the password for authentication.
 - [Proxy authentication: domain]: enter the domain for authentication.
4. Click OK to finalize the proxy configuration.

Remote Service: check the connection

After you configured the proxy, it is possible to test the connection between the printer and the service organization.

Procedure

1. Open the [Support] - [Remote Service] tab, and click on [Check connection].
2. A message displays the answer, within 30 seconds. When configured correctly, the message [The system is connected to Remote Service.] appears.
3. Now the system is able to send data to the service organization. For example, Canon Meter Manager, or [Remote Service] information.



NOTE

- For online viewing, approval of meter reads or service call entry via the web, please refer to the company website. On the website you can create an account ("My account") to request access to both services.
- You can find feedback on the status of the connection and tooltip information in the System monitor.

Remote Service: allow remote assistance

When you have made all settings required and you want to allow the service organization to remotely access the printer, you can enable remote assistance.

Procedure

1. Open the [Support] - [Remote Service] tab, and click on [Allow remote assistance].
2. A message informs the user whether a connection is made. When configured correctly, the message [Remote assistance to the system is enabled and currently accepting a connection] and two arrows appear.

When the connection with the service organization is established, a remote service operator (service technician) is able to operate the system and provide assistance remotely.



NOTE

- Since a remote assistance session is established via a point-to-point connection, only this specific system, and none of the other systems at the customer's site, can be reached.
- Click on [Stop remote assistance] when you want to terminate the connection with the service organization. This way the customer always stays in control.

Downloads and support for your product

Downloads

User guides, printer drivers (for the printers) and other resources can change without prior notice. To stay up-to-date, you are advised to download the latest resources from:

["http://downloads.cpp.canon"](http://downloads.cpp.canon)

Before you use your product, you must always download the latest safety information for your product: make sure that you read and understand all safety information in the manual entitled 'Safety Guide' .

Support

For support information please contact your Canon local representative.

Find your local contact for support from:

["http://www.canon.com/support/"](http://www.canon.com/support/)

From the Canon support page, you can also download the printer drivers for the Canon printers, their related user guides and other resources.

Index

A

Absolute colorimetric.....	164
Access control	
Enable.....	90, 91, 92
Access management.....	56, 89
Account management	
introduction.....	306
WebTools Express.....	307
Action after media request time-out.....	135
Active job.....	44, 46
Add a strip.....	239
Add leading strip	
Sheet settings.....	70
Add trailing strip	
Sheet settings.....	70
Adobe Acrobat reader	
print.....	209
Advanced settings.....	48, 49
Advanced settings for copy jobs.....	224
Advanced settings for print jobs.....	216
Advanced settings for scan jobs.....	249
Advised settings	
for copy jobs.....	234
Advised settings for scan jobs.....	255
Alignment	
Layout settings.....	71
Alignment mode	
Set.....	150
ARC Cloud support.....	120
Area to erase.....	228
Area to erase: length.....	242
Area to erase: width.....	242
Area to erase: X origin.....	242
Area to erase: Y origin.....	242
Audit log.....	331
Authorizations.....	11
Auto rotate	
set.....	149
Auto-feed the original	
description.....	191
Automatic on	
Configure.....	133
Automatic roll switch	
Set.....	147

B

Background compensation.....	253
Basic settings.....	70

C

Calibrate the scanner.....	297
Cartridge.....	287
Certificate	
details.....	103
Certificates.....	96
Change	
Settings.....	65
Check connection	
Remote Service.....	332, 333
Clean card.....	315
Clean the scanner.....	294
Clear	
the system.....	266
Clear an original jam.....	319
ClearConnect.....	19
components and function.....	22
Cloud.....	207
CMYK	
Color space definition.....	156
Collate	
Basic settings.....	70
Color feel	
Definition.....	159
Color highlighting.....	253
Color management	
Definition.....	155
Color management settings	
Defaults... 171, 172, 173, 174, 175, 176, 177, 178	
Job submission.....	167
Overview.....	166
Priorities.....	169
Color mode.....	219, 250
Basic settings.....	70
Color mode: black and white.....	260
Color mode: color.....	259
Color mode: grayscale.....	260
Components printer.....	18, 20
Components scanner.....	24
Compression.....	249
Concept	

- default settings..... 64
- Configure
 - Media request time-out..... 135
 - network settings..... 83
- Connect
 - mains supply cable and network cable..... 34
- Connection
 - Remote Service..... 333
- Consumables
 - per job..... 330
- Contactless card..... 89
- Control Smart Inbox rights..... 82
- Copy
 - half size..... 238
- Copy a specific area..... 241
- Copy dark original..... 244
- Copy job
 - default..... 221
 - delete a specific area of an original..... 242
 - Highlight colors..... 245
 - remove a strip..... 240
 - Scale..... 243
 - scale to another size..... 243
- Copy job by set..... 246
- Copy job defaults..... 73
 - WebTools Express..... 73
- Copy job presets..... 104
- Copy job settings..... 224
- Copy jobs
 - description..... 234
- Copy presets
 - on the user panel..... 222
- Copy quality..... 236, 257, 297
- Copy tile..... 45
- Core size of the media rolls..... 136
- Counter history
 - overview..... 330
- Create
 - Media size..... 182
- Current date and time..... 131
- Custom copy preset..... 106
- Custom preset..... 109
- Custom print length
 - Sheet settings..... 70
- Custom print preset..... 108
- Cut in roll-to-roll mode..... 192
- Cut method
 - Sheet settings..... 70
- Cut size..... 217, 225
- D**
- Dark original..... 244
- Default
 - External location.....
 - Default..... 123
 - Set a default external location..... 123
 - Default copy job
 - procedure..... 221
 - Default copy preset..... 105
 - Default destination for scan
 - General scan job settings..... 74
 - Default destination for scan jobs
 - description..... 74
 - Default fold templates..... 144
 - Default print destination
 - Configure..... 124
 - External location.....
 - Set a default print destination..... 124
 - Print destination.....
 - Set as default..... 124
 - Default print job..... 210
 - Default print preset..... 107
 - Default scan job
 - procedure..... 247
 - Default settings
 - concept..... 64
 - Definition
 - CMYK color space..... 156
 - Color feel..... 159
 - Color management..... 155
 - Input profile / standardization..... 156
 - output profile..... 165
 - Rendering intent..... 160
 - Rendering intents..... 161, 162, 163, 164
 - RGB color space..... 156
 - Delete
 - active job..... 265
 - Smart Inbox..... 81
 - Delete a specific area
 - description..... 242
 - Delivery..... 220, 233
 - Delivery destination 26
 - Demo print
 - print..... 326
 - Diazo print..... 244
 - Direct print..... 212
 - Disconnect
 - Mains supply cable and network cable..... 320
 - Documentation
 - Available documentation..... 14
 - Driver Express for Adobe® Postscript® 3..... 14
 - Driver Select for Microsoft® Windows®..... 14
 - Publisher Select..... 15
 - WebTools Express 14
 - Download media profiles..... 179
 - Driver Express for Adobe® Postscript® 3™
 - job submission..... 200

-
- Driver Select for Microsoft® Windows®
 - job submission..... 198
 - Dynamic bar..... 46
 - E**
 - E-shredding
 - Algorithm..... 94
 - Enable or disable..... 93
 - Number of overwrite passes..... 95
 - Earthquake provision..... 32
 - Edit a setting..... 65
 - Enable or disable scan templates..... 116
 - Energy save modes..... 134
 - Error
 - print job submission..... 209
 - Errors
 - Event list..... 325
 - Event messages
 - Overview..... 322
 - External location
 - Create..... 121
 - FTP..... 125
 - Create external location..... 121
 - FTP, SMB, WebDAV..... 121
 - Generate a certificate request..... 97
 - Home folder..... 119
 - Import a CA-signed certificate.... 99, 100, 101, 102
 - PlanWell Collaborate..... 120
 - SMB..... 128
 - USB..... 118
 - WebDAV..... 130
 - External locations..... 117
 - F**
 - Factory default
 - restore..... 69
 - Feed the original..... 190
 - File..... 249
 - File compression 259
 - File extension
 - PDF, TIFF, JPEG, CALS..... 74
 - File name for copy to Smart Inbox
 - general copy job settings..... 73
 - File name for scan to Smart Inbox
 - General scan job settings..... 74
 - File organization..... 259
 - File type..... 259
 - Finishing
 - Fold settings..... 140, 143
 - Finishing Assistant..... 139
 - Finishing device configuration..... 28
 - First language..... 131
 - Fold template..... 220, 233
 - custom..... 140
 - Embedded..... 143
 - Fold templates..... 110
 - Default..... 144
 - Folder connection panel..... 20
 - Folding
 - Automatic legend detection..... 139
 - Folding device..... 26, 30
 - foot..... 19
 - Footprint..... 33
 - FTP
 - external location..... 117
 - job submission..... 205
 - troubleshoot configuration..... 125
 - G**
 - General copy job settings..... 73
 - General scan job settings
 - description..... 74
 - Get a new license file..... 303
 - Google Chrome
 - Security settings..... 87
 - Green button..... 45
 - H**
 - Highlighted colors..... 245
 - Home folder..... 119
 - external location..... 117
 - Home screen..... 44
 - Horizontal shift
 - Layout settings..... 71
 - HTTPS..... 96
 - I**
 - Icons
 - Job states..... 60
 - Image..... 228
 - Increase productivity..... 191
 - Input profile / standardization
 - Definition..... 156
 - Internet Explorer
 - Security settings..... 85
 - Introduction
 - Account management..... 306
 - Océ Account Console..... 309
 - IPSec..... 90, 91
 - Enable..... 92
-

J

Job	
pause, resume or stop.....	265
Job management settings.....	82
Job memory full.....	148
Job pane.....	48
Job preview.....	50
Job queue.....	46
Concept.....	75
Job states	
Queue.....	60
Smart Inbox.....	60
Job submission	
Color management.....	167
Driver Express for Adobe® Postscript® 3™.....	200
Driver Select for Microsoft® Windows®.....	198
ftp.....	205
lpr.....	206
Publisher Express.....	193
Publisher Mobile.....	201
Publisher Select 3.....	196
Job submission tools	
the cloud.....	207
Jobs tab.....	76
JPEG quality.....	249

K

Key operator.....	11
-------------------	----

L

Language change.....	55
Layout settings.....	71
Leading strip.....	239
Legend	
Automatic detection.....	139
Licenses	
activation.....	300
Get a new license file.....	303
List.....	301
Lighter/Darker.....	253
Live scan view.....	45
Load	
settings from a file.....	68
Load a media roll.....	279
log in	
WebTools Express.....	57
Log out	
description.....	58
Long plot mode	
Set.....	146
Lower front cover.....	18

Lower left side cover.....	18
Lower right side cover.....	19
LPR	
job submission.....	206

M

Mains supply cable.....	34, 320
Maintenance tray.....	290
Maintenance tray drawer.....	20
Measurement unit.....	131
Media.....	216, 224
Media configuration	
Core size of the media rolls.....	136
Media profiles.....	180
Media sizes.....	183
Media types.....	180
Media configuration	
Media size.....	182
Media drawer.....	21, 272
Media drawers.....	18
Media Profile.....	179
Install.....	181
Update.....	181
Media request time-out.....	135
Media roll.....	279
Unpack.....	277
Media roll remove.....	273
Media saving	
rotation.....	149
Media selection policy	
general copy job settings.....	73
Sheet settings.....	70
Media size.....	216, 224
Create.....	182
Media sizes.....	183, 285
Media source.....	216, 224
Sheet settings.....	70
Media type.....	216, 224
Media types.....	180, 283
Microsoft Edge	
Security settings.....	88
Mirror.....	219, 250
Layout settings.....	71
Mobile printing password.....	186
Move the printer.....	40
Mozilla Firefox	
Security settings.....	86

N

Network cable.....	34, 320
Network duplex mode	
set.....	84

-
- Network settings
 - configure.....83
 - Network speed
 - set.....84
 - Number of sets
 - Basic settings.....70
 - O**
 - Océ Account Center
 - Overview.....308
 - Océ Account Console
 - introduction.....309
 - OMP file.....179
 - On/off button.....19
 - Open levers.....24
 - Optimize
 - Print productivity.....150
 - Print quality.....145
 - Optimize
 - PDF processing.....151
 - Organization.....249
 - Original.....228
 - auto-feed.....191
 - Original feed.....190
 - Original feeding table.....24
 - Original jam.....319
 - Original type.....236, 250, 257
 - Original width.....250
 - Originals exit.....24
 - Output delivery.....26
 - folding device.....26
 - receiving rack (basket).....26
 - take-up module.....26
 - Top Delivery Tray.....26
 - Output profile.....165
 - Output refeed protector.....24
 - Overview
 - Color management settings.....166
 - Overwrite passes.....95
 - P**
 - Paper.....283
 - Password encryption key.....59
 - Passwords
 - Change password in WebTools Express.....59
 - Pause
 - active job.....265
 - PDF.....151, 152
 - troubleshoot print job.....209
 - PDF Processing performance
 - Optimize.....152
 - PDF rasterization settings.....152
 - PDF render engine.....151
 - Pen settings
 - configure.....137
 - Perceptual (photo).....161
 - PlanWell Collaborate
 - Enable.....120
 - external location.....117
 - Pollution cleaning.....315
 - Positioning.....217, 225
 - Power switch.....20
 - Power user.....11
 - Preset copy job.....105
 - Preset print job.....107
 - Presets.....48, 104
 - for copy jobs.....222
 - for print jobs.....214
 - Preshared key.....92
 - Preview your job.....50
 - Print
 - demo print.....326
 - Smart Inbox.....195
 - test print.....327
 - Print Assistant
 - behavior.....153
 - Print quality.....72
 - slider.....153
 - Print delivery
 - Basic settings.....70
 - Print from a USB key.....213
 - Print job.....210
 - direct print.....212
 - Driver Express for Adobe® Postscript® 3™.....200
 - Driver Select for Microsoft® Windows®.....198
 - Publisher Select 3.....196
 - Print job defaults.....70, 71, 72
 - WebTools Express.....70
 - Print job presets.....104
 - Print job settings.....216
 - Print jobs
 - and the cloud.....51
 - Print presets
 - on the user panel.....214
 - Print productivity.....154
 - Print quality.....72, 219
 - Set.....145
 - Print quality for scanned images
 - general copy job settings.....73
 - Print surface.....315
 - Print tile.....45
 - Printer
 - components (back).....20
 - Components (front).....18
 - Printer working area.....33
-

- Problems
 - solve..... 314
- Productivity..... 191
- Proxy
 - Configure..... 332
- Publisher Express..... 184, 186, 193
 - Print job..... 203
 - Quick Response Card..... 187
- Publisher Express scan..... 264
- Publisher Mobile
 - send a print job..... 201
- Publisher Select 3..... 196

- Q**
- Quality..... 228
- Quality optimization..... 236, 257
- Quality problem..... 297
- Queue
 - Job states..... 60
- Quick Response Card..... 186

- R**
- Receiving rack (basket)..... 26
- Regional settings..... 131
- Relative colorimetric..... 163
- Remote assistance
 - Remote Service..... 332, 334
- Remote Security..... 96
 - A secure location..... 97, 99, 100, 101, 102
- Remote Service..... 332
 - Check connection..... 333
 - Remote assistance..... 334
- Remove
 - a strip..... 261
- Remove
 - all jobs from the system..... 266
- Remove a specific area
 - description..... 242
- Remove media roll..... 273
- Remove strip..... 225, 241, 250
- Rendering intent
 - Absolute colorimetric..... 164
 - Definition..... 160
 - Perceptual (photo)..... 161
 - Relative colorimetric..... 163
 - Saturation (business graphics)..... 162
- Replace the maintenance tray..... 290
- Replace the toner cartridge..... 287
- Resolution..... 250
- Restart the system
 - description..... 63
- Restore
 - factory defaults..... 69
- Restore factory defaults
 - Templates..... 115
- Resume
 - active job..... 265
- RGB color space
 - Definition..... 156
- Roll empty..... 147
- Roll-to-roll mode..... 31, 138
 - Cut..... 192
- Rotation..... 217
 - Layout settings..... 71
- Rotation mode
 - set..... 149

- S**
- Saturation (business graphics)..... 162
- Save licenses..... 302
- Save settings..... 67
- Scale..... 217, 225
 - Layout settings..... 71
 - make a half size copy..... 238
- Scan delivery retry interval
 - General scan job settings..... 74
- Scan destination
 - description..... 117
- Scan job
 - default..... 247
- Scan job defaults
 - description..... 74
 - WebTools Express..... 74
- Scan job presets..... 104
- Scan job settings..... 249
- Scan jobs..... 255
 - and the cloud..... 51
- Scan quality..... 236, 253, 257, 297
- Scan template
 - on the user panel..... 248
- Scan templates..... 110
- Scan tile..... 45
- Scan to a mobile device..... 264
- Scan to USB..... 262
- Scan-to-file..... 259
- Scanner
 - components..... 24
- Scanner calibration..... 297
- Scanner clean..... 294
- Scanner original jam..... 319
- Scanner Professional..... 29
- Second language..... 131
- Secure
 - Your location..... 97, 99, 100, 101, 102, 103
- Security patches..... 271

-
- Security settings
 - For Google Chrome..... 87
 - For Internet Explorer.....85
 - For Microsoft Edge.....88
 - For Mozilla Firefox..... 86
 - Sets.....246
 - Settings
 - Change..... 65
 - Settings file
 - load.....68
 - Setup menu.....47
 - Sheet settings..... 70
 - Shut down the system
 - description.....63
 - Sleep mode..... 134
 - Smart Access..... 45
 - Smart card.....89
 - Smart Inbox
 - Close.....81
 - Concept..... 75
 - Create..... 78
 - Delete..... 81
 - external location.....117
 - Job states.....60
 - print..... 195
 - SMB
 - external location.....117
 - troubleshoot configuration..... 128
 - Software update
 - User panel.....269
 - WebTools Express..... 270
 - Solve
 - problems with jobs..... 314
 - Spool threshold
 - Set..... 148
 - Start value for ### in the copy file name
 - general copy job settings..... 73
 - Start value for ### in the scan file name
 - General scan job settings..... 74
 - Stop
 - active job.....265
 - Strip
 - remove a strip..... 261
 - Strip remove..... 240
 - Support
 - Downloads.....335
 - Manuals..... 335
 - Printer drivers.....335
 - Switch on the printing system..... 36
 - System
 - shut down or restart..... 63
 - System administrator.....11
 - System menu.....44, 46
 - System monitor..... 61
 - System patches..... 271
- T**
- Take-up module.....26, 31
 - Template for scan jobs.....248
 - Templates.....48
 - Create..... 111
 - Delete..... 112
 - Export.....113
 - Fold.....110
 - Import.....114
 - Restore factory defaults.....115
 - Scan.....110
 - Test print
 - print..... 327
 - The cloud
 - main concept..... 51
 - Time format..... 131
 - Time zone.....131
 - Timer
 - User session time-out..... 132
 - Toner cartridge..... 287
 - Toner cartridge (black)..... 18
 - Toner cartridge (cyan)..... 18
 - Toner cartridge (magenta)..... 18
 - Toner cartridge (yellow)..... 18
 - Top cover..... 18, 24
 - Top delivery tray..... 18, 26
 - Trailing strip.....239
 - Transparency flattening..... 152
 - Transparent top cover..... 18
 - Troubleshoot
 - Event messages..... 322
 - print job submission..... 209
 - Troubleshoot FTP
 - create external location..... 125
 - Troubleshoot SMB
 - create external location..... 128
 - Troubleshoot WebDAV
 - create external location..... 130
 - Turn off the printing system.....38
- U**
- Unpack
 - Media roll.....277
 - Update..... 268, 269, 270, 271
 - Upload new licenses..... 304
 - Upper back cover.....20
 - USB
 - enable or disable..... 118
 - external location.....117
 - USB port..... 18
-

Index

USB print.....	213
USB scan.....	262
User authentication.....	56, 89
User panel.....	19, 22
User roles.....	11
User session	
Time-out.....	132

V

Vertical shift	
Layout settings.....	71
View the settings	
WebTools Express.....	66

W

WebDAV	
external location.....	117
troubleshoot configuration.....	130
working with the cloud.....	51
WebTools Express	
account management.....	307
change the language.....	55
Copy job defaults.....	73
description.....	54
Jobs tab.....	76
load the settings from a file.....	68
log in	57
Passwords.....	59
Print job defaults.....	70
restore factory defaults.....	69
save the settings in a file.....	67
Scan job defaults.....	74
User roles.....	11
View and check the settings.....	66
Wheel.....	20
Wi-Fi.....	186
Wipeout correction.....	151
Workflow.....	254
Working hours	
Configure.....	133



Canon Inc.

canon.com

Canon U.S.A., Inc.

usa.canon.com

Canon Canada Inc.

canon.ca

Canon Europe Ltd

canon-europe.com

Canon Latin America Inc.

cla.canon.com

Canon Production Printing Australia Pty. Ltd.

anz.cpp.canon

Canon China Co., Ltd.

canon.com.cn

Canon Singapore Pte. Ltd.

sg.canon

Canon Hongkong Co., Ltd.

hk.canon